

- Engine 113.964, 156.980, 272.967, 273.963, 642.940 in model 164
with code 580 (Air-conditioning system)
- Engine 113.964, 156.980, 272.967, 273.963, 642.940 in model 164
with code 581 (Automatic air conditioning)

Modification notes

30.03.2017	"Technical note" added	AH54.00-P-0001-01A	
23.03.2017	"Technical note" added	AH83.30-P-0005-01P	
23.03.2017	Safety note changed	AS83.00-Z-0006-01A	

- 1 Screw
2 Refrigerant line
3 Screw
4 Refrigerant line
5 Bolts
A9 Refrigerant compressor
A9x1 Refrigerant compressor connector

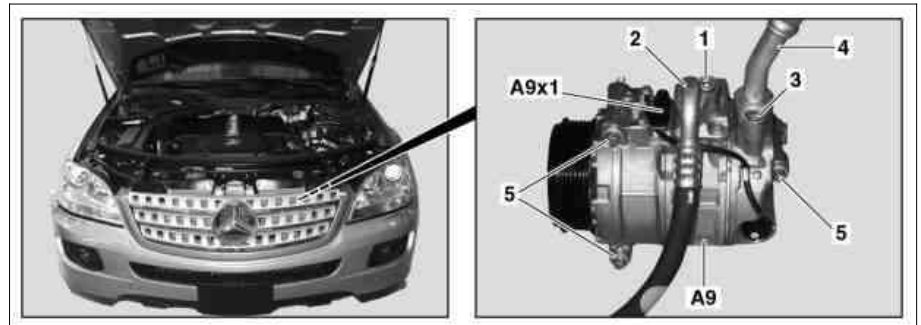

P83.55-2126-04





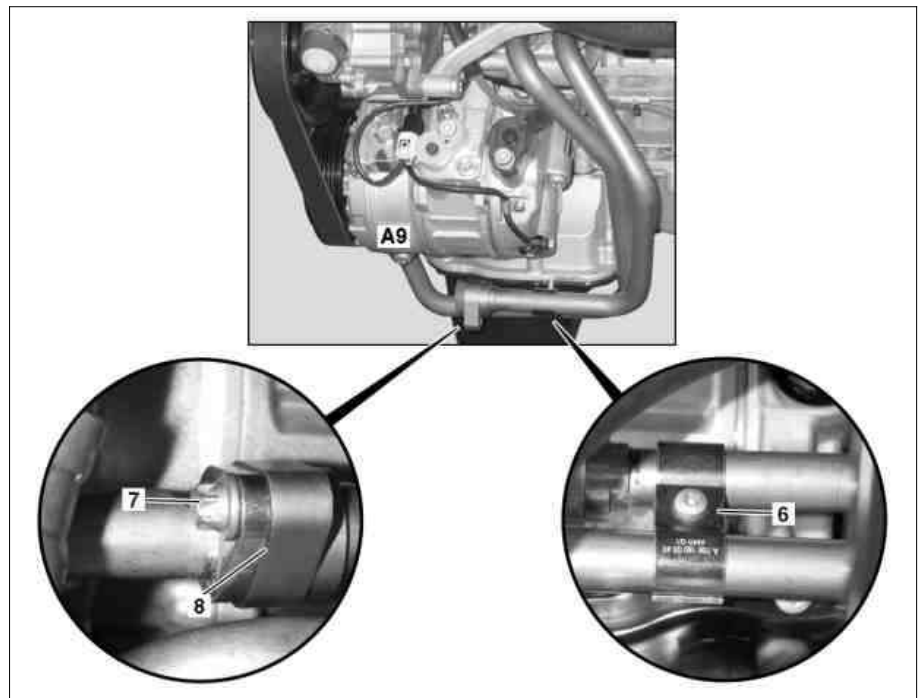

Shown on engine 156.980



- 6 Double clamp
7 Screw
8 Oil line flange connection
A9 Refrigerant compressor



P83.55-2136-06

⚠ Warning	Risk of poisoning caused by inhaling overheated refrigerant vapors from an air conditioning system containing R134a. Risk of injury to skin and eyes caused by contact with liquid R134a refrigerant and when working on pressurized parts	Never perform welding work on or near a closed air conditioning system. No smoking or open flames. Wear safety glasses and protective gloves. Work only in well ventilated rooms. Carry out repair work on the air conditioning system circuit only after the system has been evacuated.	AS83.00-Z-0006-01A
⚠ Danger	Risk of death caused by vehicle slipping or toppling off of the lifting platform.	Align vehicle between vehicle lift columns and position the four support plates at the vehicle lift support points specified by the vehicle manufacturer.	AS00.00-Z-0010-01A
Topical note	Information on preventing damage to electronic components due to electrostatic discharge		AH54.00-P-0001-01A

9	Seal exposed lines and connections with suitable plugs	 <p>Open connections on the air conditioning system must generally be sealed. Otherwise, ingressed dirt and moisture will damage the air conditioning system.</p>  Record plug	*129589009100
10	Unscrew bolt (3)	<p>Nm Engine 272.967 in model 164.156/186 with code 580 (Air-conditioning system) Engine 272.967 in model 164.156/186 with code 581 (Automatic air conditioning) Engine 273.963 in model 164.172/886 with code 580 (Air-conditioning system) Engine 273.963 in model 164.172/886 with code 581 (Automatic air conditioning) Bolt, refrigerant line to refrigerant compressor</p> <p>Nm Engine 113.964, 156.980, 642.940 in model 164 with code 580 (Air-conditioning system) Engine 113.964, 156.980, 642.940 in model 164 with code 581 (Automatic air conditioning) Screw/bolt, refrigerant lines to A/C compressor</p>	*BA83.55-P-1003-01M *BA83.55-P-1003-01R
11	 Remove refrigerant line (4) Compressor oils (specification 362.1)	<p>i Installation: The sealing rings of the refrigerant line (4) must be replaced and moistened with compressor oil.</p>	BB00.40-P-0362-01A
12	Seal exposed lines and connections with suitable plugs	 <p>Open connections on the air conditioning system must generally be sealed. Otherwise, ingressed dirt and moisture will damage the air conditioning system.</p>  Record plug	*129589009100
13	 Drain off engine oil and catch using a suitable container	<p>Engine 156.980 in model 164.177 with code 580 (Air-conditioning system) Engine 156.980 in model 164.177 with code 581 (Automatic air conditioning)</p>	AP18.00-P-0101GZA
14	Remove double clamp (6)	<p>Engine 156.980 in model 164.177 with code 580 (Air-conditioning system) Engine 156.980 in model 164.177 with code 581 (Automatic air conditioning)</p>	
15	Remove screw (7) from oil line flange connection (8)	<p>Engine 156.980 in model 164.177 with code 580 (Air-conditioning system) Engine 156.980 in model 164.177 with code 581 (Automatic air conditioning)</p>	
16	Disconnect oil line flange connection (8) and collect engine oil in suitable container	<p>Engine 156.980 in model 164.177 with code 580 (Air-conditioning system) Engine 156.980 in model 164.177 with code 581 (Automatic air conditioning)</p>	
17	Seal exposed lines and connections with suitable plugs	 Record plug	*129589009100
18	Remove screw/bolts (5)	<p>Nm Engine 272.967 in model 164.156/186 with code 580 (Air-conditioning system) Engine 272.967 in model 164.156/186 with code 581 (Automatic air conditioning) Engine 273.963 in model 164.172/886 with code 580 (Air-conditioning system) Engine 273.963 in model 164.172/886 with code 581 (Automatic air conditioning) Screw/bolt, refrigerant compressor to timing case/crankcase/engine support</p> <p>Nm Engine 113.964, 156.980, 642.940 in model 164 with code 580 (Air-conditioning system) Engine 113.964, 156.980, 642.940 in model 164 with code 581 (Automatic air conditioning) Screw/bolt, A/C compressor to timing case and left engine support</p>	*BA83.55-P-1001-01M *BA83.55-P-1001-01R
19	Remove refrigerant compressor (A9) and take out downwards	<p>i The refrigerant line (2) and refrigerant line (4) must be placed outside the working area.</p>	
20	Install in the reverse order		
	Concluding tasks		

21	Check engine oil level and correct	Engine 156.980 in model 164.177 with code 580 (Air-conditioning system) Engine 156.980 in model 164.177 with code 581 (Automatic air conditioning)	
 AP			AP18.00-P-0101GZA
 Warning	Risk of accident from vehicle starting off by itself when engine running. Risk of injury (bruises and burns) resulting from working on the engine while it is being started or when it is running.	Secure vehicle to prevent it from starting off by itself. Wear closed and snug-fitting work clothes. Do not touch hot or rotating parts.	AS00.00-Z-0005-01A
22	Perform engine test run and check for proper operation and leak tightness		

 Refrigerant compressor

Number	Designation	Engine 272	Engine 273
BA83.55-P-1001-01M	Screw/bolt, refrigerant compressor to timing case/crankcase/engine support Nm	20	20

 Refrigerant compressor

Number	Designation	Model 164 with engine 113.964, 156.980, 642.820/822/940
BA83.55-P-1001-01R	Screw/bolt, A/C compressor to timing case and left engine support Nm	20

 Refrigerant compressor

Number	Designation	Engine 272	Engine 273
BA83.55-P-1003-01M	Bolt, refrigerant line to refrigerant compressor M8 Nm	20	20

 Refrigerant compressor

Number	Designation	Model 164 with engine 113.964, 156.980, 642.820/822/940
BA83.55-P-1003-01R	Screw/bolt, refrigerant lines to A/C compressor Nm	20

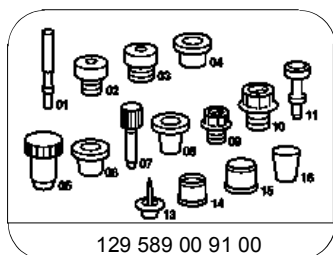

Record plug