

ENGINES 272, 273 in MODEL 164, 251

Camshaft adjuster for exhaust camshafts

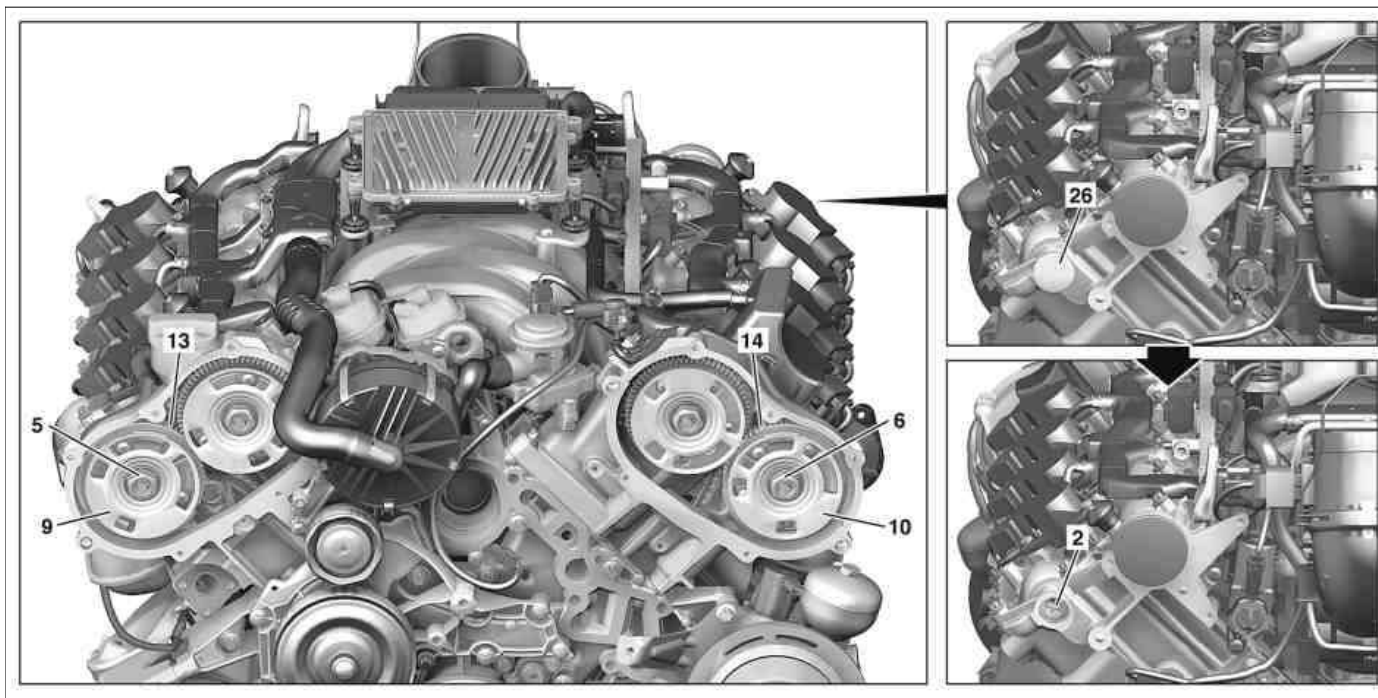

P05.20-2243-09

- 2 Exhaust camshaft
- 5 Center valve on the right
- 6 Center valve on the left
- 13 Right camshaft adjuster
- 18 Dowel pin
- 19 Pin
- 20 Bore in camshaft adjuster

- 9 Pulse wheel on the right
- 10 Pulse wheel on the left
- 13 Right camshaft adjuster

- 14 Left camshaft adjuster
- 26 Cap

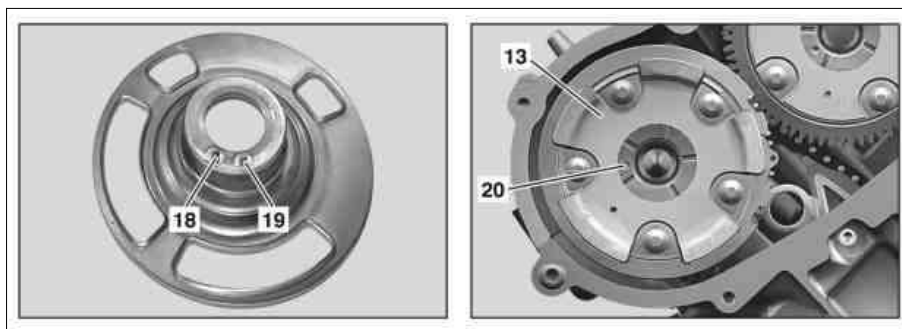

P05.20-2244-04

- 21 Dowel pin in camshaft adjuster
- 22 Bore in camshaft

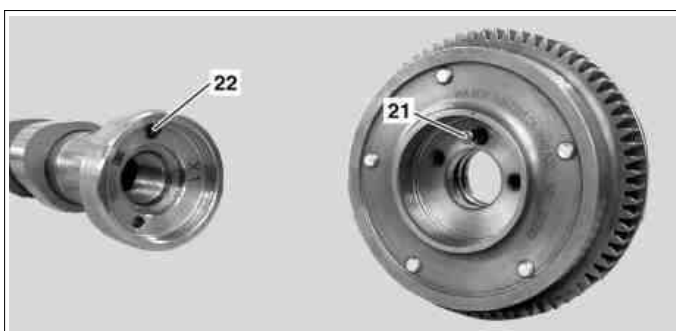

P05.20-2235-10

☒ ☒	Remove/install		
1	Turn key in ignition lock to position "0"	<p>i Vehicles with code 889 Keyless Go: Press Keyless Go start/stop button repeatedly until the ignition is switched off. Remove Keyless Go transmitter card or transmitter key from vehicle and store beyond reach of the transmitter (at least 2 m).</p>	
2	Remove air filter housing		AR09.10-P-1150GZA
3	Remove front cover at respective cylinder head	Left cylinder head	AR01.30-P-5700GZA

		Right cylinder head	AR01.30-P-5700GZC
4.1	Remove centrifuge	When removing from camshaft adjuster on the right (13).	AR01.20-P-2100GZA
4.2	Remove cap (26)	When removing from camshaft adjuster on the left (14).	
5	Turn engine at crankshaft center bolt in direction of engine rotation to a 40° crank angle after ignition TDC and check position of camshafts		AR05.20-P-6010-01VB
6	Lock gear backlash compensation for respective camshaft adjuster (13 or 14)		AR05.20-P-7201-05VA
7	Detach center valve (5 or 6) for respective camshaft adjuster (13 or 14)	<p>i Observe loosening direction.</p> <p>Nm</p>	AR05.20-P-7201-06VA *BA05.20-P-1009-02A
8	Remove center valve (5 or 6) for respective camshaft adjuster (13 or 14) and remove pulse wheel (9 or 10)	<p>⚠ Check dowel pin (18) and pin (19). If a dowel pin (18) or pin (19) is sheared off then this must be removed from respective camshaft adjuster (13 or 14).</p> <p>ⓘ Installation: Always replace pulse wheel (9 or 10). When tightening center valve (5 or 6) there is a risk that dowel pin (18) or pin (19) may shear at the pulse wheel (9 or 10). Lubricate center valve (5 or 6) at the contact surface with the pulse wheel (9 or 10) before assembling.</p> <p>i Installation: Align dowel pin (18) for pulse wheel (9 or 10) with the fitted bore (20) in the camshaft adjuster (13 or 14).</p>	
9	Counterhold respective exhaust camshaft (2) at the rear using a suitable tool and detach camshaft adjuster (13 or 14) forwards from the exhaust camshaft (2)	<p>i Installation: Lubricate contact surfaces on exhaust camshaft (2) and camshaft adjuster (13 or 14) before assembling camshaft adjuster (13 or 14).</p> <p>i Installation: Align dowel pin (21) in camshaft adjuster (13 or 14) to fitted bore (22) in exhaust camshaft (2) and install camshaft adjuster (13 or 14) in its basic position: See "Check basic position of camshafts".</p>	AR05.20-P-6010-01VB
10	Install in the reverse order		
	⏪ Checking		
	⚠ Danger!		
11	<p>Risk of accident caused by vehicle starting off by itself when engine is running. Risk of injury caused by contusions and burns during starting procedure or when working near the engine as it is running</p> <p>Conduct engine test run and check engine for leaks</p>	<p>Secure vehicle to prevent it from moving by itself.</p> <p>Wear closed and snug-fitting work clothes.</p> <p>Do not touch hot or rotating parts.</p>	AS00.00-Z-0005-01A

Nm Camshaft, camshaft adjustment

Number	Designation		Engine	Engine
			272	273
BA05.20-P-1009-02A	Center valve for pulse wheel/ camshaft adjuster to camshaft	Nm	145	145