



DTB

Date: April 23, 2009
 Order No.: S-B-03.30/08i
 Supersedes: S-B-03.30/08h dated October 24, 2008
 Group: 03

Revision History

Revision	Date	Purpose
i	4/23/09	Applicable Models Updated / Technical Content Revised
h	10/24/08	Damage Code (Scenario 2 and 3) Revised
g	10/20/08	Applicable Models (164.172/886) and Warranty Information Updated
f	6/26/08	Model 204 & Scenario 3 Added, Engine Nos. Added (Scen.2), Model 251.156 Added, Warranty Info. Updated
e	4/24/08	Op Code (05-7211 – Scenario 1) Removed
d	4/16/08	Damage Code (Scenario 2) Revised
c	4/3/08	Parts Information Corrected
b	3/28/08	Warranty Information Corrected
a	3/26/08	Content Revised and Warranty Information Revised
-	8/23/07	Initial issue

SUBJECT: Model 164.156/172/186/871/886
Model 171.454/456
Model 203.052/054/056/087/092
Model 204.054/056/081/987
Model 209.356/372/456/472
Model 211.056/072/087/090/256/287
Model 216.371/386
Model 219.372
Model 221.171/186
Model 230.471
Model 251.156/165
Equipped with M272 or M273 Engine
Check Engine Light On / Fault Codes Current and/or Stored in ME-SFI Control
Module / Oil Leaking at Camshaft Adjustment Solenoid

This bulletin has been created and maintained in accordance with MBUSA-SLP S423QH001, Document and Data Control, and MBUSA-SLP S424HH001, Control of Quality Records.

If you receive customer reports of the check engine light being illuminated and one of the following Fault Code Scenarios (no corresponding Fault Codes in Scenario 3) is found in the above model vehicles, follow the applicable procedure below to resolve.

i **Note:** Corresponding protocols (i.e. ME Control Module log file related to DTC code) must always be included with any returned parts as indicated on the Warranty Return Form Printout Matrix (RFPM). If the documentation is missing or does not support the diagnosis, the warranty claim may be debited.

i **Note:** Flashing the ME Control Module will not resolve these issues and is unnecessary at this point.

i **Note:** Mobil Training Coach (MTC) “M272 Engine Timing” can be referred to when performing repairs. However, this DTB takes precedence in terms of technical and warranty content as well as referred WIS documents. Any parts specified in the DTB or in referenced WIS documents should be replaced accordingly (e.g. seals, gaskets or bolts and screws as required).

i **Note:** When preparing / cleaning any surfaces for resealing, extreme care must be taken not to damage surfaces with sharp tools. It is absolutely not permissible to use any abrasive materials (i.e. sand paper, abrasive pads, etc.) for cleaning resalable surfaces. Proper application of sealant is a must as excessive sealant can result in damage to the engine (refer to MTC listed in the note above). Failure to follow these precautions could result in severe and permanent engine damage.

Fault Code Scenario 1: DTC ^{P0017} 1200 ^{P0016} and/or 1208 is/are present in ME-SFI control module. The fault codes are recorded as current and/or stored in the fault memory. When the fault memory is erased and the engine is restarted, the fault codes reoccur immediately. This is due to the positioning of the timing chain driven camshafts relative to the crankshaft and **can be caused by a worn sprocket on the balance shaft** on engine M272 or by a worn guide (idler) gear for the timing chain on engine M273. Figure 1, 2 and 3 show extremely worn sprocket gears. Figure 4, for comparison, shows a new sprocket gear.

i **Note:** In rare cases, a stretched timing chain might be the reason for the DTC fault codes when the sprocket does not exhibit any signs of wear.

Applicable Models (Not Applicable to Model 164.156, 204 or 216.386): Equipped with M272 Engine Up to Serial No. 2729..30 468993 or M273 Engine Up to Serial No. 2739..30 088611.

The material for the balance shaft sprocket and the timing chain guide wheel (idler) was modified on engines past the serial numbers listed above.

Procedure 1 (Follow all steps and the order as described):

- a) Perform a visual inspection for any wear of the teeth (damage profile) on the sprocket of the balance shaft (M272) or of the guide (idler) gear for timing chain (M273) by removing the timing case cover on the engine. Refer to WIS instructions AR01.40-P-8000* (* - applies to a specific model designation e.g. AR01.40-P-8000SX – models 221, 216). Ensure the use of the Special Tool W001 589 81 09 00 when removing / installing timing case cover.

i **Note:** Refer to Figure 1 through 3 for examples of damaged / worn sprocket profile. Refer to Figure 4 for example of a new gear (for comparison).

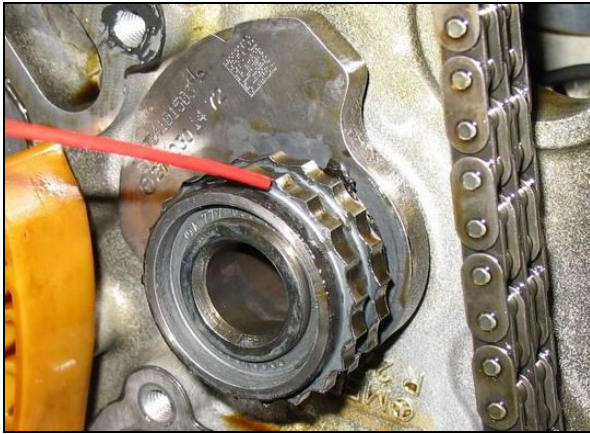

Figure 1 – Damaged/worn S-B-03.30/08a

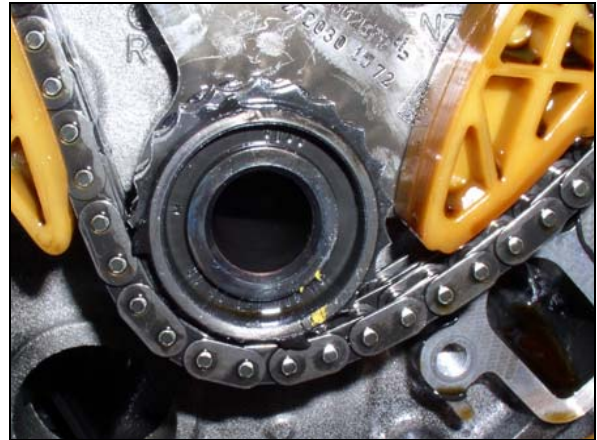

Figure 2 – Damaged/worn S-B-03.30/08i

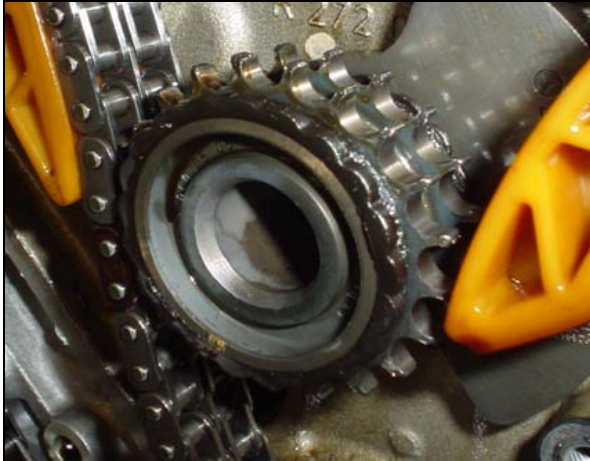

Figure 3 – Damaged/worn S-B-03.30/08i



Figure 4 – **New Gear** (comparison) S-B-03.30/08i

- b) Only if worn (sprocket teeth profile damaged), replace the balance shaft on engine M272 or replace the guide (idler) gear of the chain drive on engine M273 as per WIS instructions AR03.20-P-1000* (* - applies to a specific model designation e.g. AR03.20-P-1000VA – model 171).

i **Note:** Cylinder heads are not needed to be removed.

i **Note:** When performing repair, pay attention to cleanliness. Remove any debris, shavings and contaminants.

i **Note:** When replacing the balance shaft on engine M272, the counterweight must also be replaced. The balance shaft and counter weight are specific to engine designation. Order individual parts and kits specifically to a VIN number.

- c) Replace the engine oil pump. Refer to WIS instructions AR18.10-P-6020* (* - applies to a specific model designation).

- d) Replace the chain tensioner.

! **Caution!** New timing chain tensioner must be installed and **only after the engine head covers (valve covers) are installed / bolted on**. Failure to observe that, will result in the over tightening the timing chain which will ultimately lead to engine head damage. Note the timing chain tensioner is a single use part. Once the tensioner is installed, it cannot be taken out or readjusted, doing so will result in over tightening of the timing chain as well.

- e) Change engine oil and filter.

i **Note:** Use inexpensive, appropriate engine oil from MB sheet 229.1 and 229.3 for this step.

- f) Drive with engine at high load and rpm for approx. 15 miles.

- g) After 15 miles, drive, change engine oil and filter once more. Use appropriate engine oil from MB sheet 229.5 in this step.
- h) Replace all four of the camshaft adjustment solenoids with A272 051 01 77 – this step applies only to Scenario 1.

P0014 P0015 P0024 P0025 P0011 P0012 P0021

Fault Code Scenario 2: One or more of the fault codes 0059, 0060, 0063, 0064, 0271, 0272, 0275, and P0022 0276 is/are present in ME-SFI control module. The fault codes are recorded as current and/or stored in the fault memory. If current and/or stored, **these codes are caused by a malfunctioning camshaft adjustment solenoid.**

Applicable Models: Equipped with M272 Engine Up to Serial No. 2729..30 759427 or M273 Engine Up to Serial No. 2739..30 193592. Engines produced after serial nos. listed above are already equipped with improved camshaft adjustment solenoids (A272 051 01 77).

Procedure 2: Diagnose each DTC as per Star Diagnosis. If it is determined the solenoid is faulty, replace with solenoid A272 051 01 77 as per appropriate WIS instructions. Refer to WIS instructions AR05.20-P-7295* (* - applies to a specific model designation e.g. AR05.20-P-7295RTB – model 251).



Note: For this scenario only, replace the solenoid that has a corresponding fault code. Copy of the SDS short test and ME Control Module log file related to DTC code must accompany returned parts. If the documentation is missing or does not support the diagnosis, the warranty claim may be debited (i.e. only two Fault Codes but all four solenoids are changed or low voltage situation might result in a code to be stored but not current).

Fault Scenario 3: Camshaft adjustment solenoid is leaking oil, and no Fault Codes are current or stored in the ME Control Module. Determine the cause of the leak. The solenoid can be leaking from under the sealing ring or through the harness connector.

Applicable Models: Equipped with M272 Engine Up to Serial No. 2729..30 895140 or M273 Engine Up to Serial No. 2739..30 236360

Procedure 3:

- a) If the leak appears to be between the solenoid and the cylinder head replace solenoid sealing ring (Figure 5, 145).
- b) If the leak is from the electrical connector, replace the solenoid (Figure 5, 140).



Note: Provide description of where the leaking occurred and mark the replaced solenoid.

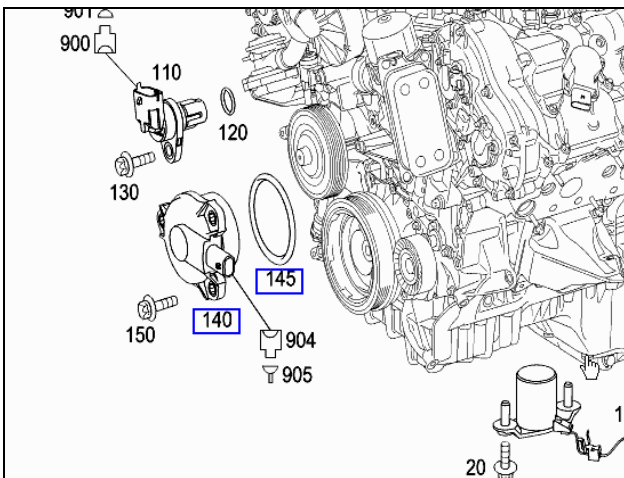
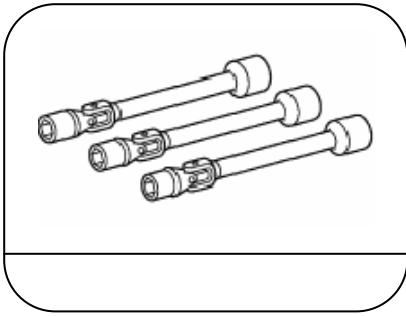

Figure 5

S-B-03.30/08i

Special Tools



W001 589 81 09 00



Note: Always refer to EPC for the latest parts information and use the correct VIN number when specifying parts.

Parts Information

Qty.	Part Name	Part Number
1	Solenoid (M272/M273)	A272 051 01 77
1	Seal ring	A019 997 37 45
1	Seal ring	A000 466 18 80
1	Chain Tightener (tensioner)	A272 050 08 11 ¹
1	Balance shaft sprocket repair kit for 2.5 liter engine 272.920 (includes shaft, counterweights and chain tensioner)	A272 030 00 13
1	Balance shaft sprocket repair kit for 3.0 liter engine 272.94X (includes shaft, counterweights and chain tensioner)	A272 030 01 13
1	Balance shaft sprocket repair kit for 3.5 liter engine 272.96X/272.97X (includes shaft, counterweights and chain tensioner)	A272 030 02 13
1	Guide (idler) gear repair kit for engine 273 (includes guide sprocket w/ bearing, chain tensioner, oil pump, solenoids, seals...)	A272 030 03 13

¹ Refer to EPC for a part number related to applicable model.



Note: The following allowable labor operations should be used when submitting a warranty claim for this repair. This information has been generated on April 22, 2009 Please refer to Netstar → Star TekInfo → Star Time for the most current labor time allowance.

In Case of Warranty

Operation:

Scenario 1

- Short test perform (54-1011)
- Ground cable – elec. system battery, D&C (when separating elec. connectors) (54-7989)
- Ground cables on both batteries remove/install (when disconnecting elect. connectors w/o accidental contact protection) (54-7991)
- Ground cables on both batteries remove/install (when disconnecting elect. connectors w/o accidental contact protection) vehicles as of modification year (54-7992)
- Ground cable to battery negative terminal replace vehicle as of modification year (54-7996)
- Timing chain cover – (engine removed), R&R (01-8005)
- Timing chain cover, R&R / seal (01-8000)
- Engine compartment panels – bottom (all), R&R (61-1069)
- Engine compartment panel, bottom – front & rear part, R&R (61-1070)
- Engine compartment trim at bottom, remove/install (61-1105)
- Front engine compartment paneling, remove/install (vehicle w/ offroad package) (61-1101)
- Engine with manual trans., R&R (01-2400)
- Engine with auto. trans., R&R (01-2800)

Continued on Page 6

In Case of Warranty

Operation:

Scenario 1 - continued

- Manual transmission, D&C from engine (engine with transmission removed) (26-2200)
- Autom. Transmission, R&R (engine with transmission removed) (27-2110)
- Remove / install balance shaft, replace if necessary (engine 272 removed) (03-4731)
- Timing chain idler sprocket, replace (timing chain cover removed) (05-8052)
- Engine oil pump - (main/lower oil pan removed), R&R / replace (18-6022)
- Engine oil pump - R&R / replace as required (oil pan removed) (18-6023)
- Perform oil change (00-6555)
- Perform test drive (00-9150)
- Solenoid units – (all) var. valve time-cam control mech, replace (05-7290)
- Wheel alignment, check (40-6500)
- Front wheel toe angle adjust (with vehicle alignment check) (40-4064)
- Engine oil and filter, change (00-2080)
- Oil change, perform (00-6555)
- Road test (00-9151)
- Additional to road test (00-0000)

Scenario 2:

- Short test perform (54-1011)
- Test program – after short test, perform (54-1012)
- Magnet – Camshaft Adjustment Camshaft A, Replace (05-7300)
- Magnet – Camshaft Adjustment Camshaft B, Replace (05-7301)
- Magnet – Camshaft Adjustment Camshaft C, Replace (05-7302)
- Magnet – Camshaft Adjustment Camshaft D, Replace (05-7303)

Scenario 3:

- Magnet – Camshaft Adjustment Camshaft A, Replace (05-7300)
- Magnet – Camshaft Adjustment Camshaft B, Replace (05-7301)
- Magnet – Camshaft Adjustment Camshaft C, Replace (05-7302)
- Magnet – Camshaft Adjustment Camshaft D, Replace (05-7303)

In Case of Warranty

Damage Code	Operation Number	Time (hrs.)	Model Indicator (s)
Scenario 1 03043 D1 (Engine 272)	54 1011	0.3 hrs.	BA, BE, CA, CB, CC, Q6, Q7, Q8, Q9, QA, S7, S8, T7, T8, U6, U7, X1, X3, XA, Z1, Z7
	54 7989	0.1 hrs.	CA, CB, CC, XA
		0.2 hrs.	X1, X3, Z1, Z7
		0.3 hrs.	BA, BE, S7, S8, T7, T8, U6, U7
01 8005	0.4 hrs.	Q6, Q7, Q8, Q9, QA	
	5.9 hrs.	CA, CB, S7, S8, T7, U6	
	6.0 hrs.	T8, U7, X1, X3	
	6.4 hrs.	BA, BE	
	6.7 hrs.	Z1, Z7	
	6.9 hrs.	Q6, Q7, Q9	
	7.1 hrs.	CC, Q8, QA	
	7.4 hrs.	XA	
61 1069	0.3 hrs.	CA, CB, CC, T7, T8, U6, U7	
	0.4 hrs.	X1, X3, XA	

Continued from Page 6

In Case of Warranty

Damage Code	Operation Number	Time (hrs.)	Model Indicator (s)
Scenario 1 (cont.) 03043 D1 (Engine 272)	61 1070	0.3 hrs.	BA, BE, Q6, Q7, Q8, Q9, QA, S7, S8
	61 1105	0.3 hrs.	Z1, Z7
	61 1101	0.5 hrs.	Z1, Z7
	01 2800	6.0 hrs.	X1, X3
		6.1 hrs.	T7, U6
		6.6 hrs.	CA, CB
		7.4 hrs.	BA, BE
		7.6 hrs.	XA
		7.7 hrs.	S7, S8, Z1, Z7
		8.0 hrs.	CC
		9.0 hrs.	Q6, Q7, Q9
	01 2400	11.2 hrs.	Q8, QA
		11.8 hrs.	T8, U7
		5.6 hrs.	X1, X3
	26 2200	5.9 hrs.	CA
0.4 hrs.		CA, X1, X3	
27 2110	1.4 hrs.	Z1, Z7	
	1.5 hrs.	BA BE CA CB S7 S8 T7 U6 X1 X3	
	1.7 hrs.	Q6 Q7 Q9	
	1.8 hrs.	CC, XA	
	1.9 hrs.	T8, U7	
	2.2 hrs.	Q8, QA	
	03.4731	7.3 hrs.	CA, CB
		7.4 hrs.	S7, S8, T7, T8, U6, U7, X1, X4
8.0 hrs.		BA BE Z1 Z7	
8.6 hrs.		Q6, Q7, Q9	
8.7 hrs.		CC	
8.8 hrs.		Q8, QA	
8.9 hrs.		XA	

Continued on Page 8

In Case of Warranty

Damage Code	Operation Number	Time (hrs.)	Model Indicator (s)
Scenario 1 (cont.) 03043 D1 (Engine 272)	18 6022	0.3 hrs.	BA, BE, CA, CB, CC, Q6, Q7, Q8, Q9, QA, T7, T8, U6, U7, X1, X3, XA, Z1, Z3
		0.4 hrs.	S7, S8
	00 6555	0.5 hrs.	BA, BE, CA, CB, CC, Q6, Q7, Q8, Q9, QA, S7, S8, T7, T8, U6, U7, X1, X3, XA, Z1, Z3
	00 9150	0.3 hrs.	BA, BE, CA, CB, CC, Q6, Q7, Q8, Q9, QA, S7, S8, T7, T8, U6, U7, X1, X3, XA, Z1, Z3
	05 7290	1.7 hrs.	CA, CB, CC, XA
		1.8 hrs.	BA, BE, S7, S8, T7, T8, U6, U7, X1, X3, Z1, Z7
		2.1 hrs.	Q6, Q7, Q8, Q9, QA
	40 6500	0.7 hrs.	BA, BE, Z1, Z7
	40 4064	0.1 hrs.	BA, BE, Z1, Z7
	00 6555	0.3 hrs. *	BA, BE, CA, CB, CC, Q6, Q7, Q8, Q9, QA, S7, S8, T7, T8, U6, U7, X1, X3, XA, Z1, Z3
	00 0000	0.3 hrs. *	BA, BE, CA, CB, CC, Q6, Q7, Q8, Q9, QA, S7, S8, T7, T8, U6, U7, X1, X3, XA, Z1, Z3
Scenario 1 05103 D1 (Engine 273)	54 1011	0.3 hrs.	AA, AD, DA, DE, EA, EC, SA, SB, T9, TA, R5, Y3, Z5
	54 7989	0.1 hrs.	DE
		0.2 hrs.	EA, EC, Y3, Z5
		0.3 hrs.	SA, SB
	54 7991	0.3 hrs.	AA, AD, DA
	54 7992	0.2 hrs.	R5
	54 7996	0.4 hrs.	T7, T8, T9, TA
		0.6 hrs.	U6, U7
	01 8000	10.4 hrs.	SA, SB
		10.5 hrs.	T9, Y3
		11.4 hrs.	AA, DA
		12.6 hrs.	Z5
		12.8 hrs.	EA, EC
		13.5 hrs.	R5
		16.0 hrs.	TA
	16.4 hrs.	AD, DE	
	61 1069	0.3 hrs.	T9, TA, Y3
		0.4 hrs.	AA, AD, DA, DE
		0.7 hrs.	R5
	61 1070	0.3 hrs.	SA, SB

Continued on the Page 9

Continued from Page 8

Damage Code	Operation Number	Time (hrs.)	Model Indicator (s)
Scenario 1 (cont.)	61 1105	0.3 hrs.	Z5
05103 D1 (Engine 273)	61 1101	0.5 hrs.	EA, EC
	05 8052	0.1 hrs.	AA, AD, DA, DE, EA , EC, R5, SA, SB, T9, TA, Y3, Z5
	18 6022	0.3 hrs.	DE, TA, Z1
		0.4 hrs.	AA, AD, DA
		0.5 hrs.	EA, EC, Z5
	18 6023	0.3 hrs.	SA, SB, T9, Y3
		0.4 hrs.	R5
	05 7290	1.8 hrs.	AA, DA, EA, EC, SA, SB, Z1, Z5
		2.1 hrs.	R5
		2.3 hrs.	AD, DE, T9, TA,
		2.4 hrs.	Y3
	00 6555	0.5 hrs.	AA, AD, DA, DE, EA , EC, R5, SA, SB, T9, TA, Y3, Z5
	00 9151	0.3 hrs. *	AA, AD, DA, DE, EA , EC, R5, SA, SB, T9, TA, Y3, Z5
Additional time for 2 nd road test.	00 0000	0.3 hrs. *	AA, AD, DA, DE, EA , EC, R5, SA, SB, T9, TA, Y3, Z5
NOTE: Claims for solenoid valves in both Scenario 2 & 3 need to be split over multiple lines (not more that one solenoid per line). Parts must be claimed under the damage code which corresponds to the failed solenoid per DTC or leak. Failure to comply will result in denial of warranty claims.			
Scenario 2 (Select Appropriate Damage Code)	54 1011 (Claimable once per RO)	0.3 hrs.	AA, AD, BA, BE, CA, CB, CC, DA, EA, EC, Q6, Q7, Q8, Q9, QA, R5, S7, S8, SA, SB, T7, T8, T9, TA, U6, U7, X1, X3, Y3, Z1, Z5
	54 1012 (Claimable once per RO)	0.5 hrs.	AA, AD, BA, BE, DA, EA, EC, Q6, Q7, Q8, Q9, QA, R5, S7, S8, SA, SB, T7, T8, T9, TA, U6, U7, X1, X3, Y3, Z1, Z5
05N03 73 (Right Intake)	05 7301 (B)	0.6 hrs	AA, AD, BA, BE, CA, CB, CC, DA, EA, EC, S7, S8, SA, SB, T7, T8, T9, TA, U6, U7, X1, X3, Y3, Z1, Z5
		0.7 hrs	Q6, Q7, Q8, Q9, QA, R5
05A03 73 (Left Intake)	05 7302 (C)	0.6 hrs	AA, BA, BE, CA, CB, CC, DA, EA, EC, S7, S8, T7, T8, U6, U7, X1, X3, Z1, Z5
		0.7 hrs	Q6, Q7, Q8, Q9, QA, R5
		1.1 hrs	AD, SA, SB, T9, TA, Y3
05N04 73 (Right Exhaust)	05 7300 (A)	0.4 hrs	AA, AD, BA, BE, CA, CB, CC, DA, EA, EC, S7, S8, SA, SB, T7, T9, U6, X1, X3, Y3, Z1, Z5
		0.5 hrs	Q6, Q7, Q8, Q9, QA, R5, T8, TA, U7

Continued on the Page 10

Damage Code	Operation Number	Time (hrs.)	Model Indicator (s)
Scenario 2 (cont) 05A04 73 (Left Exhaust)	05 7303 (D)	0.4 hrs	SA, SB
		0.9 hrs	CA, CB, CC
		1.0 hrs	AA, BA, BE, DA, EA, EC, S7, S8, T7, T8, T9, TA, U6, U7, X1, X3, Y3, Z1, Z5
		1.1 hrs	Q6, Q7, Q8, Q9, QA, R5
		1.2 hrs	AD
NOTE: Claims for solenoid valves in both Scenario 2 & 3 need to be split over multiple lines (not more than one solenoid per line). Parts must be claimed under the damage code which corresponds to the failed solenoid per DTC or leak. Failure to comply will result in denial of warranty claims.			
Scenario 3 (Select Appropriate Damage Code)			
05N03 04 (Right Intake)	05 7301 (B)	0.6 hrs	AA, AD, BA, BE, CA, CB, CC, DA, EA, EC, S7, S8, SA, SB, T7, T8, T9, TA, U6, U7, X1, X3, Y3, Z1, Z5
		0.7 hrs	Q6, Q7, Q8, Q9, QA, R5
05A03 04 (Left Intake)	05 7302 (C)	0.6 hrs	AA, BA, BE, CA, CB, CC, DA, EA, EC, S7, S8, T7, T8, U6, U7, X1, X3, Z1, Z5
		0.7 hrs	Q6, Q7, Q8, Q9, QA, R5
		1.1 hrs	AD, SA, SB, T9, TA, Y3
05N04 04 (Right Exhaust)	05 7300 (A)	0.4 hrs	AA, AD, BA, BE, CA, CB, CC, DA, EA, EC, S7, S8, SA, SB, T7, T9, U6, X1, X3, Y3, Z1, Z5
		0.5 hrs	Q6, Q7, Q8, Q9, QA, R5, T8, TA, U7
05A04 04 (Left Exhaust)	05 7303 (D)	0.4 hrs	SA, SB
		0.9 hrs	CA, CB, CC
		1.0 hrs	AA, BA, BE, DA, EA, EC, S7, S8, T7, T8, T9, TA, U6, U7, X1, X3, Y3, Z1, Z5
		1.2 hrs	Q6, Q7, Q8, Q9, QA, R5
		1.2 hrs	AD

* Maximum time allowed with a separate time punch. Ensure that punches are labeled as NON time.

i Note: When claiming any of the above repairs, please be aware of potential overlapping labor. Unjustified replacements of camshaft solenoids will be debited back to dealers. Engine control module protocols must be attached and checked for the corresponding error codes when replacing multiple solenoids due to stored DTCs. The operation code must match the corresponding damage code (05N03, 05N04, 05A03, 05A04) otherwise claims will be debited back to dealers.