

Shown on right cylinder head

- 1 Camshaft adjuster
- 2 Bolts
- 3 Camshaft bearing cap
- 4 Camshafts

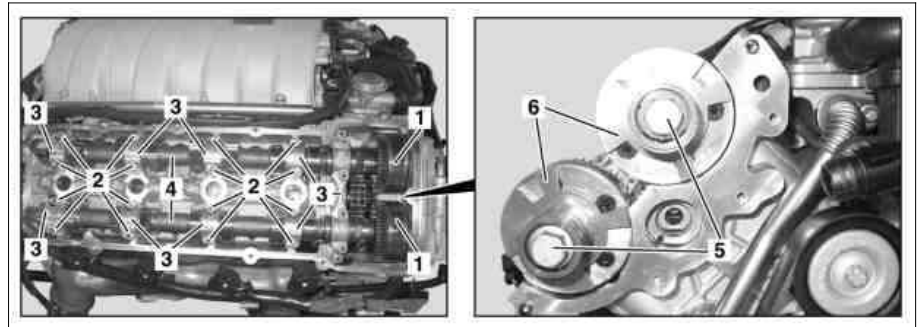

P05.20-2277-04

Tightening sequence on right cylinder head

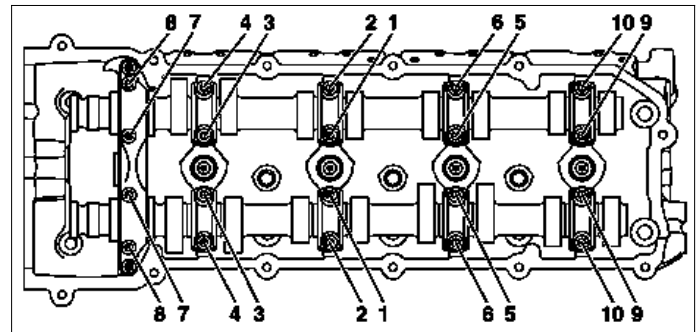





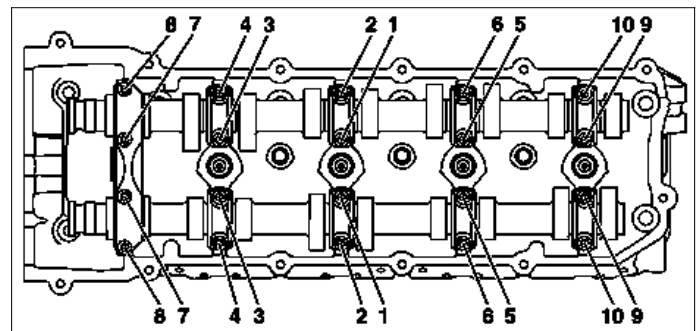





P05.20-2278-10

Tightening sequence on left cylinder head



P05.20-2279-10

| | | | |
|---|---|--|---|
| | Removing | | |
| | Risk of explosion caused by fuel igniting, risk of poisoning caused by inhaling and swallowing fuel and risk of injury to eyes and skin caused by contact with fuel | No fire, sparks, open flames or smoking. Pour fuels only into suitable and appropriately marked containers. Wear protective clothing when handling fuel. | AS47.00-Z-0001-01A |
| | Risk of injury caused by fingers being pinched or crushed when removing, installing or aligning hoods, doors, trunk lids, liftgates or sliding roof | Keep body parts and limbs well clear of moving parts. | AS00.00-Z-0011-01A |
| | Notes on self-locking nuts and bolts | | AH00.00-N-0001-01A |
| | Risk of explosion caused by oxyhydrogen gas. Risk of poisoning and caustic burns caused by swallowing battery acid. Risk of injury caused by burns to skin and eyes from battery acid or when handling damaged lead-acid batteries | No fire, sparks, open flames or smoking. Wear acid-resistant gloves, clothing and glasses. Only pour battery acid into suitable and appropriately marked containers. | AS54.10-Z-0001-01A |
| 1 | Switch off ignition | | |
| 2 | Remove partition wall between wheel wells | Model 251 | AR62.30-P-2400RT |
| 3 | Remove air filter housing | Model 164, 251 Model 204, 212 Model 209, 211, 219 Model 216, 221 Model 230 | AR09.10-P-1150GZS AR09.10-P-1150CMG AR09.10-P-1150TMG AR09.10-P-1150SMG AR09.10-P-1150RMG |
| 4 | Remove spark plugs | Only if it is not possible to crank engine due to high compression. Model 164, 251 Model 204, 212 Model 209, 211, 219 | AR15.12-P-1010GZS AR15.12-P-1010CMG AR15.12-P-1010TMG |

| | | | |
|---|---|--|---|
| | | Model 216, 221 Model 230 | AR15.12-P-1010SMG AR15.12-P-1010RMG |
| 5 | Rotate engine at crankshaft center bolt in direction of rotation of engine to a 40° crankshaft angle after top dead center (TDC) on cylinder 1 |  Rotate engine at crankshaft in running direction until scribe mark 40° on pulley / vibration damper corresponds with scribe mark on timing case. | |
| 6 | Remove cylinder head covers | Model 164, 251 Model 204, 212 Model 209, 211, 219 Model 216, 221 Model 230 | AR01.20-P-5014GZS AR01.20-P-5014CMG AR01.20-P-5014TMG AR01.20-P-5014SMG AR01.20-P-5014RMG |
| 7 | Remove all camshaft adjusters (1) | | AR05.20-P-7201AMG |
| 8 | Remove bolts (2) for camshaft bearing cap (3) |  If camshaft bearing caps (3) have no identification markings, the original position must be marked. Interchanged bearing caps can lead to engine damage. | AR05.20-P-6992-09AMG |
| 9 | Remove camshafts (4) |  Identify the position of camshafts (4) in the cylinder head. If the camshafts (4) have no identification markings for the intake and exhaust side, these must be marked. | |
|  | Checking | | |
| 10 | Check camshafts (4) and camshaft bearing caps (3) for galling and score marks | | |
|  | Install | | |
| 11 | Insert the camshafts (4) |  Follow the camshaft markings. Oil the bearing surfaces! | |
| 12 | Install camshaft bearing caps (3) |  Observe tightening procedure!  | AR05.20-P-6992-09AMG *BA01.30-P-1001-01U |
| 13 | Turn camshafts (4) into basic position |  Lock camshafts (4) using holding device and straightedge.  | *156589006100 |
| 14 | Install all camshaft adjusters (1) | | AR05.20-P-7201AMG |
| 15 | Install cylinder head covers | Model 164, 251 Model 204, 212 Model 209, 211, 219 Model 216, 221 Model 230 | AR01.20-P-5014GZS AR01.20-P-5014CMG AR01.20-P-5014TMG AR01.20-P-5014SMG AR01.20-P-5014RMG |
| 16 | Install spark plugs | If necessary Model 164, 251 Model 204, 212 Model 209, 211, 219 Model 216, 221 Model 230 | AR15.12-P-1010GZS AR15.12-P-1010CMG AR15.12-P-1010TMG AR15.12-P-1010SMG AR15.12-P-1010RMG |
| 17 | Remove/install between the wheel well liners | Model 251 | AR62.30-P-2400RT |
| 18 | Install air filter housing | Model 164, 251 Model 204, 212 Model 209, 211, 219 Model 216, 221 Model 230 | AR09.10-P-1150GZS AR09.10-P-1150CMG AR09.10-P-1150TMG AR09.10-P-1150SMG AR09.10-P-1150RMG |
| 19 | Risk of accident caused by vehicle starting off by itself when engine is running. Risk of injury caused by contusions and burns during starting procedure or when working near the engine as it is running Carry out engine test run | Secure vehicle to prevent it from moving by itself. Wear closed and snug-fitting work clothes. Do not touch hot or rotating parts. | AS00.00-Z-0005-01A |

Cylinder head

| Number | Designation | Engine 156 |
|--------------------|---|---------------|
| BA01.30-P-1001-01U | Bolt, camshaft bearing cap/bearing bridge | M6 Nm 10 |

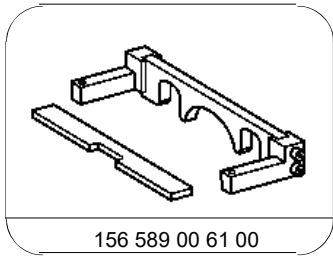

156 589 00 61 00

Holding device