

AR42.10-P-0161-01B	Apply brake pad paste to brake pads		
--------------------	-------------------------------------	--	--

Repair materials

Number	Designation	Order number
BR00.45-Z-1057-06A	MB brake paste Molykote (copper colored)	A 001 989 87 51
BR00.45-Z-1083-06A	MB Never Seeze brake paste (gray)	A 001 989 94 51 12
BR00.45-Z-1084-06A	MB Plastilube brake paste (brownish)	A 002 989 37 51

i 1 or 2 piston floating brake caliper "ATE", "Bosch", "TRW" or "Lucas" in model 204, 207, 212, 218 on front or rear axle and 1 piston floating brake caliper "TRW" in model 166 on rear axle.
Contact surfaces may not be greased.

2, 4, 6 or 8-piston fixed brake caliper "Brembo"

- 1 Apply light coating of grease to contact surfaces with arrows only!
Only model 197, 212, 218 without code (B07) Ceramic brake system and only on the rear axle: Lightly grease brake pad backing plates in the contact area of the brake pistons.
i Only use MB brake paste Molykote (copper colored).



P42.10-2742-01

4-piston fixed brake caliper "ATE" in model 463 on front axle or 2-piston fixed brake caliper "ATE" in model 171, 203, 209 on rear axle

- 1 Apply light coating of grease to contact surfaces with arrows only!
i For brake pads with damper plates: Fill grease pockets (1) MB brake paste.
i Only use MB brake paste Never Seeze (gray).

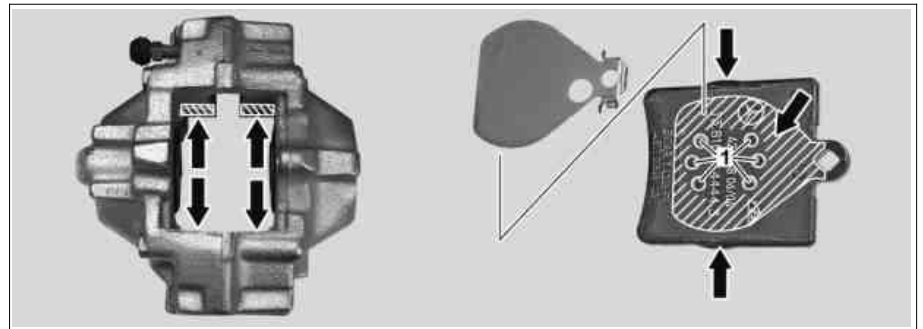

P42.10-2734-04

1-piston floating brake caliper "Bosch" in model 211 on front axle or in model 463 on rear axle

- 1 Apply light coating of grease to contact surfaces with arrows only!
w Do **not** grease damper plates of inner brake pads, as otherwise the rubber boots may swell up!
i Only use MB brake paste Never Seeze (gray).

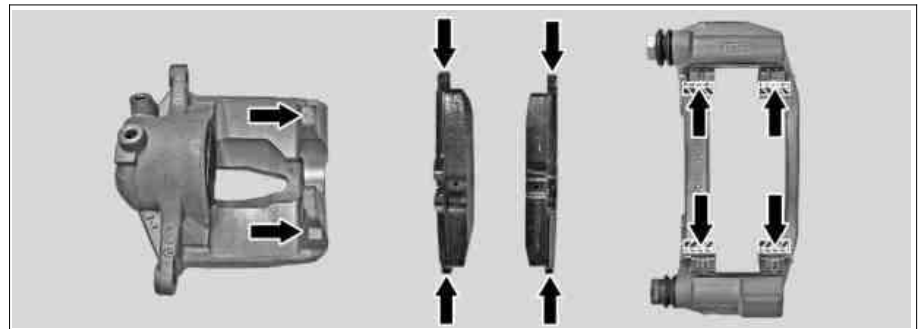

P42.10-2735-10

1-piston floating brake caliper "TRW" or "Lucas" in model 171, 203, 209 on front axle

- 1 Apply light coating of grease to contact surfaces with arrows only!
w Do **not** grease the pad and brake carriers, otherwise there may be problems with noise!
i Only use MB brake paste Never Seeze (gray).

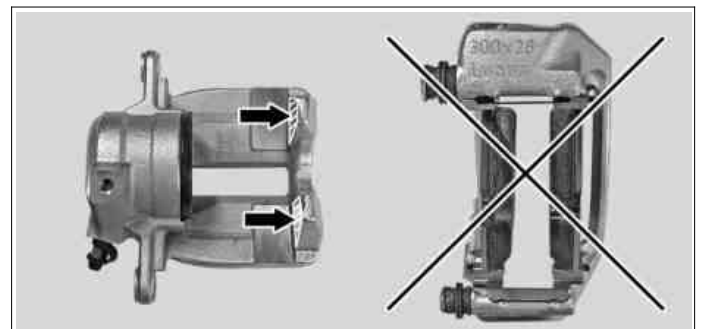

P42.10-2736-10

1-piston floating brake caliper "TRW" or "Lucas" in model 168, 169, 245 on front or rear axle

- 1 Apply light coating of grease to contact surfaces with arrows only!
- ⊗ For brake pads with self-adhesive pad carriers do **not** grease the contact surfaces in the floating brake caliper (2)!
- i** Grease contact surfaces on brake carrier (3) **before** assembling the anti-rattle springs (4)! Do **not** grease the anti-rattle springs (4)!
- i** Only use MB brake paste Never Seeze (gray).

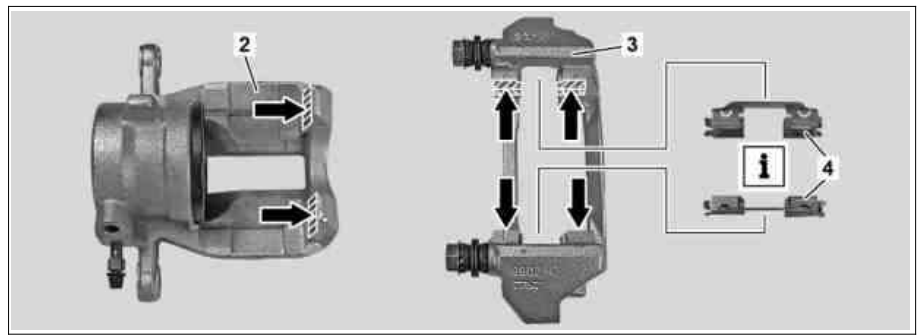

P42.10-2737-04

1, or 2-piston floating brake caliper "ATE" on front or rear axle

- 1 Apply light coating of grease to contact surfaces with arrows only!
- i** Only use MB brake paste Plastilube (brownish).

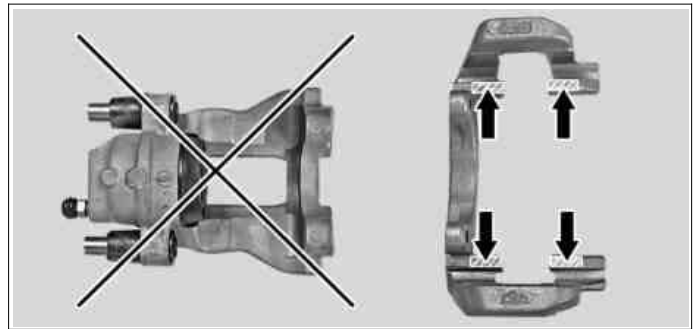

P42.10-2812-10