

AR01.20-P-5014-03TI	Bolt tightening procedure for cylinder head cover		
---------------------	---	--	--

Modification notes

9.4.10	Value changed: bolt, cylinder head cover on cylinder head	*BA01.20-P-1001-01P
--------	---	---------------------

Nm Crankcase ventilation, cylinder head cover

Number	Designation	Engine 642		
BA01.20-P-1001-01P	Bolt, cylinder head cover to cylinder head	Stage 1, apply	Nm	4
		Stage 2, initial torque	Nm	6
		Stage 3, final torque	Nm	9

Tightening of the bolts must take place according to the specified sequence in the scheme.
 Loosen bolts in reverse order.
 The bolts should be tightened any further after the cold test.

The right hand cylinder head cover

i Tighten cylinder head cover bolts in the numerical sequence.

- 1 Tighten bolts 8 and 11 to Stage 1.
- 2 Tighten bolts (1 - 30) to Stage 2.
- 3 Tighten bolts (1 - 30) to Stage 3.

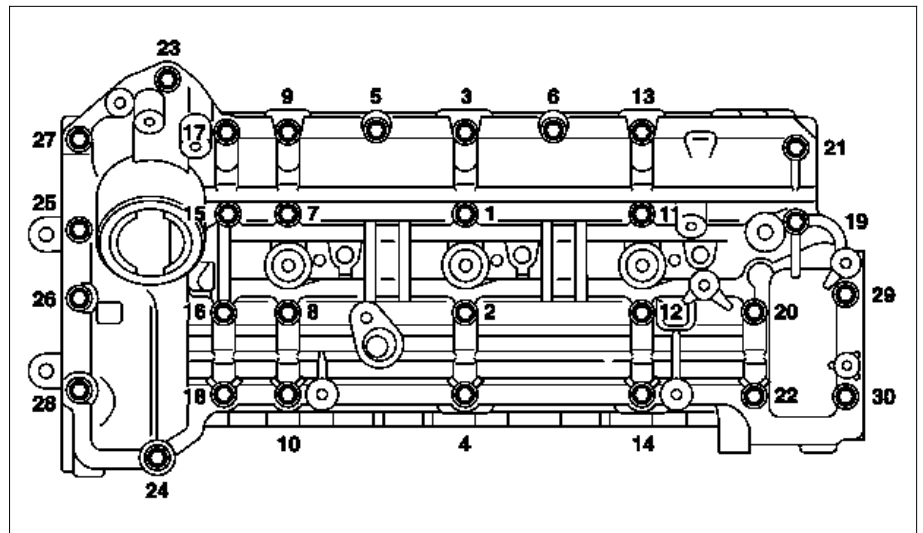

P01.20-2165-05

Left cylinder head cover

i Tighten cylinder head cover bolts in the numerical sequence.

- 1 Tighten bolts 8 and 11 to Stage 1.
- 2 Tighten bolts (1 - 28) to Stage 2.
- 3 Tighten bolts (1 - 28) to Stage 3.

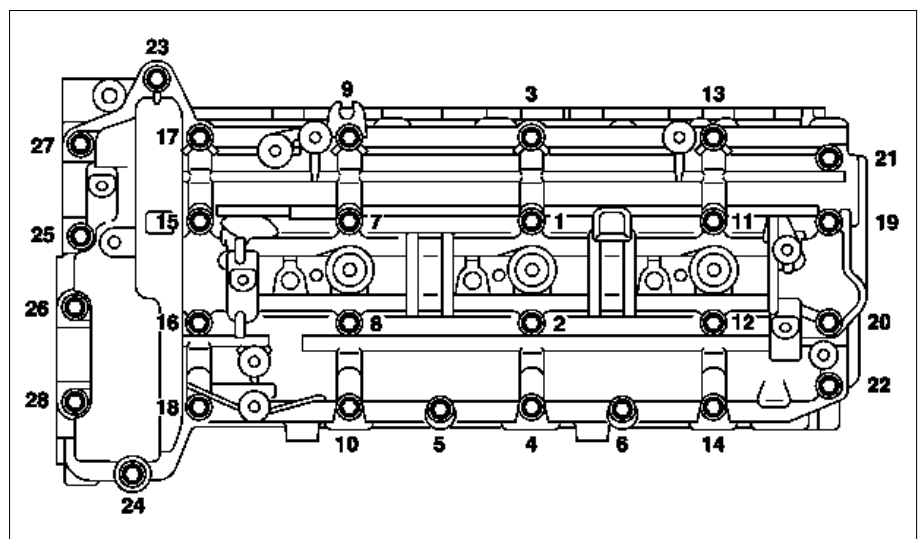

P01.20-2164-05