

AZ88.00-P-0001-03GZ	Converting rear bumper	Model 164.1 as of code (809) Model year 2009	
---------------------	------------------------	--	--

i Check components removed from standard bumper before assembly and replace if damaged.

⚠ Pay attention to paint damage.

1 Insert rear paneling bottom section (2) into rear bumper paneling (1) and arrest.

i The catch tabs on the rear paneling bottom section (2) should catch correctly in the rear paneling (1)

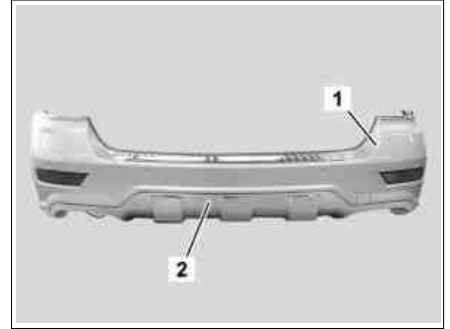

P88.20-3322-01

2 Fasten rear paneling bottom section (2) on inside of rear paneling (1) on right and left with two lock nuts (3) each.

3 Fasten rear paneling bottom section (2) on inside of rear paneling (1) on right and left with one sheet metal nut each and one 4.8×19 round Allen head bolt (5).

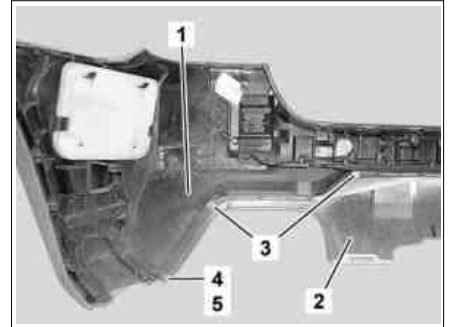

P88.20-3323-01

4 Insert bracket (6) on right and left into rear paneling (1) and fasten with one expansion rivet (7) each.

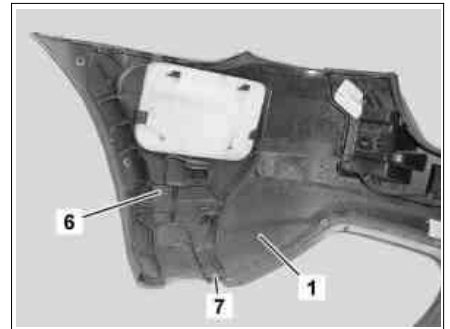

P88.20-3324-01

5 Insert console bracket (8) on right and left between bracket (6) and rear paneling (1) and fasten with two blind rivets (9) each.

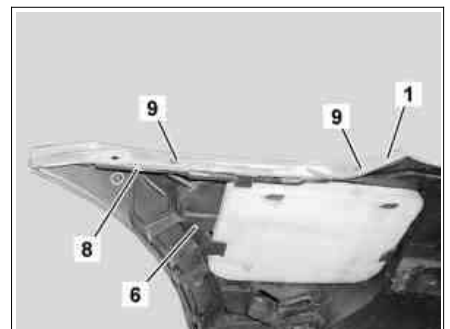

P88.20-3325-01

6 Install guard plate (10) on rear paneling (1).

i The guide lugs on the protective plate (10) must be seated correctly in the rear paneling (1).

7 Fasten guard plate (10) on inside of rear paneling (1) with six lock nuts (11) (see arrows).

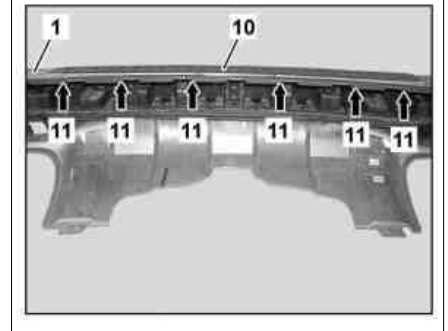
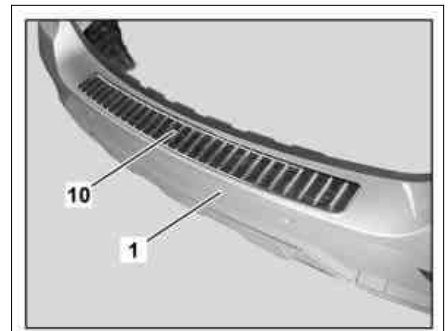

P88.20-3326-03

8 Insert basic carrier (12) into rear paneling (1) and arrest.

i The catch tabs on the basic carrier (12) must arrest correctly in the rear paneling (1).

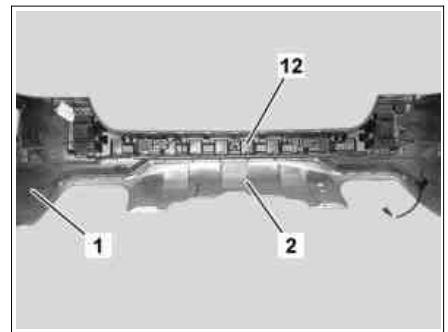

P88.20-3327-01

9 Install gaskets (14) on right and left on threaded pins (15).

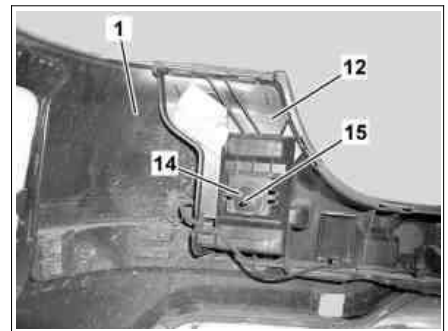

P88.20-3328-01

10 Insert reflectors (16) on right and left into rear paneling (1) and arrest.

i The reflectors (16) must arrest correctly in the rear paneling (1).

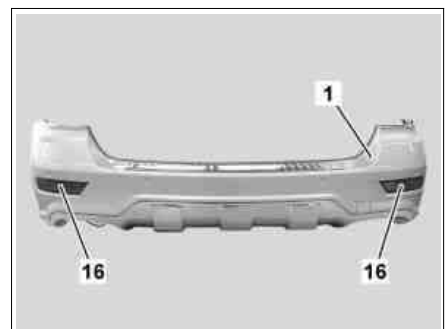

P88.20-3329-01

Vehicles with Parktronic system (PTS)

code 220

- 11 Insert PTS wiring harness (23) with connected PTS ultrasonic sensors into basic carrier (12) and fix in place at specified attachment points.
- 12 Insert right rear outer PTS ultrasonic sensor (B8/7), right inner PTS ultrasonic sensor (B8/8), left inner PTS ultrasonic sensor (B8/9) and left outer PTS ultrasonic sensor (B8/10) into brackets on rear bumper paneling (1).

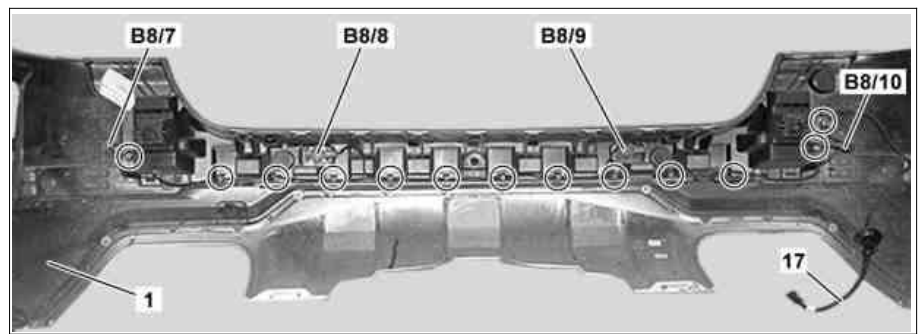

P88.20-3330-04

- 13 Hook check strap (18) into towing eye cover (19) and rear paneling (1).
- 14 Insert towing eye cover (19) into rear paneling (1).

i The towing eye cover (19) should arrest correctly in the rear paneling (1).

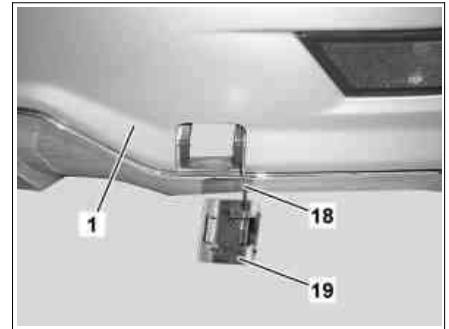

P88.20-3331-01

- 15 Insert soundproofing (20) on right and left into brackets (6).

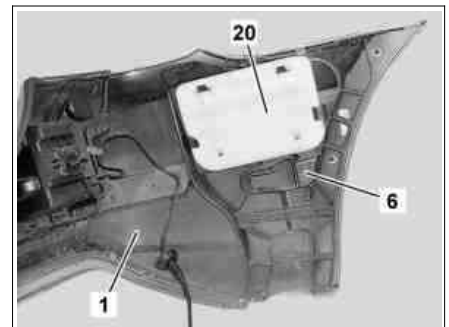

P88.20-3332-01