

Engine 272
Engine 273

i The lines (A or 1) identify the sealant paths.

i The sealing surface must be cleaned. The sealant must only be applied to the specified surface in the form of a bead with a height and width of 2.0 mm (± 0.5 mm). The sealant must be processed within 10 min. The sealant bead must not be spread. Use only the sealant indicated in the repair materials.

Oil pan bottom section for engine with front sump without code M005



P01.45-2221-06

Oil pan top section on engine 272 with front sump without code M005

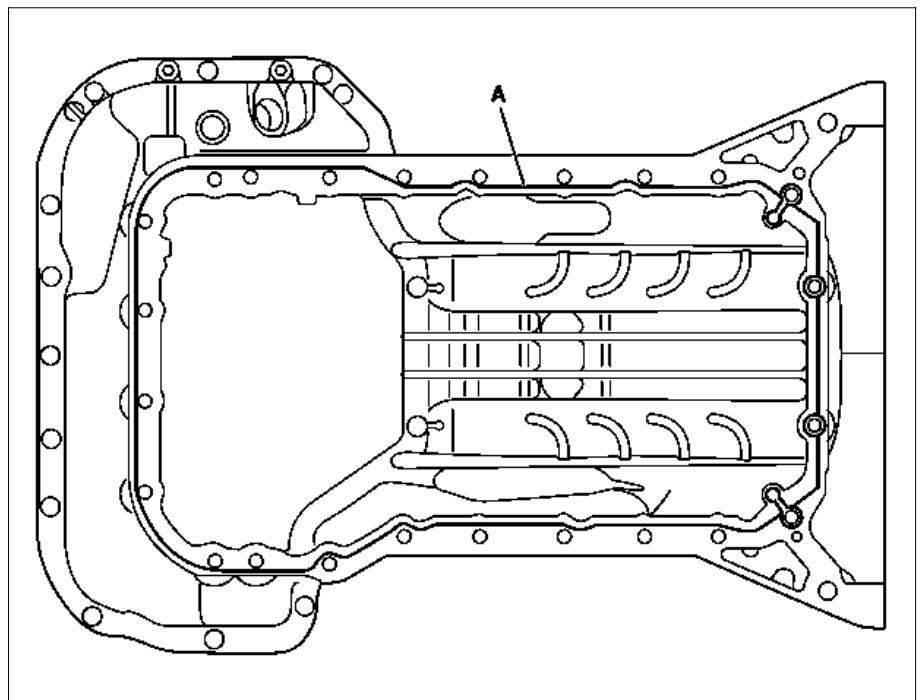

P01.45-2272-06

Oil pan bottom section for engine with front sump with code M005

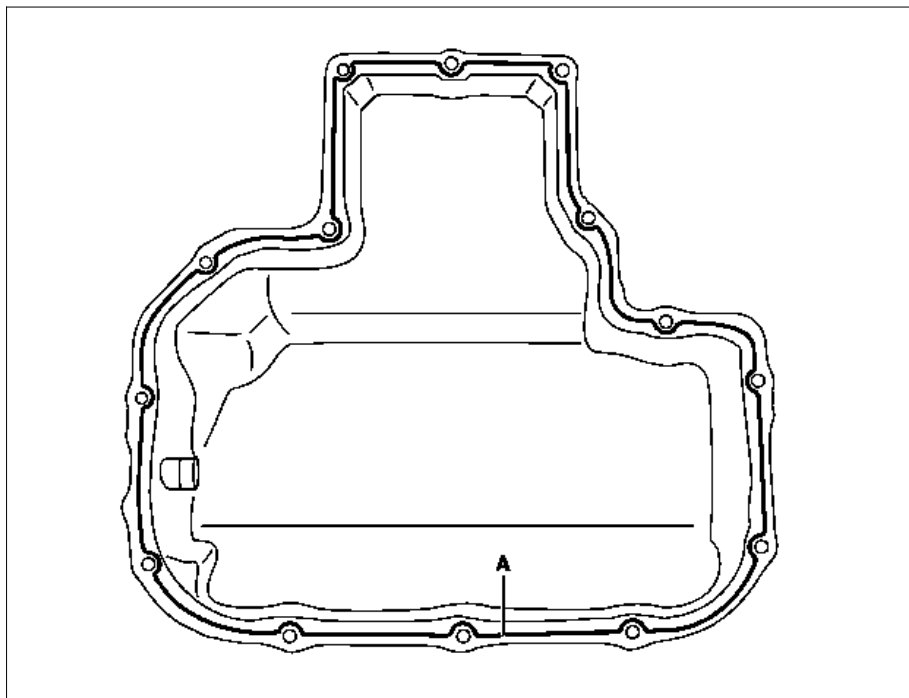

P01.45-2193-06

Oil pan top section on engine 272 with front sump with code M005

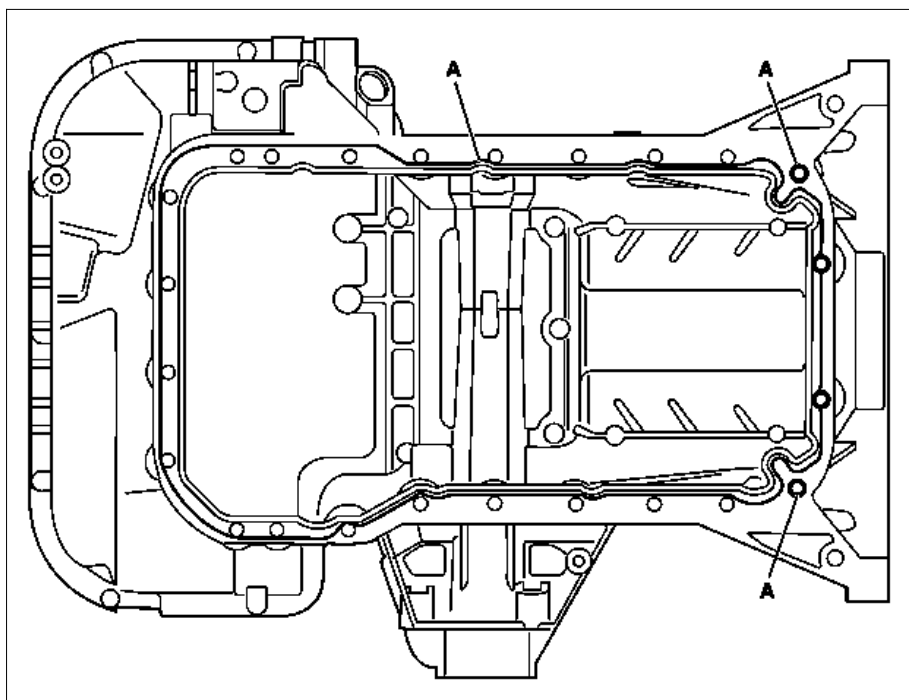

P01.45-2275-06

Oil pan bottom section for engine with middle sump

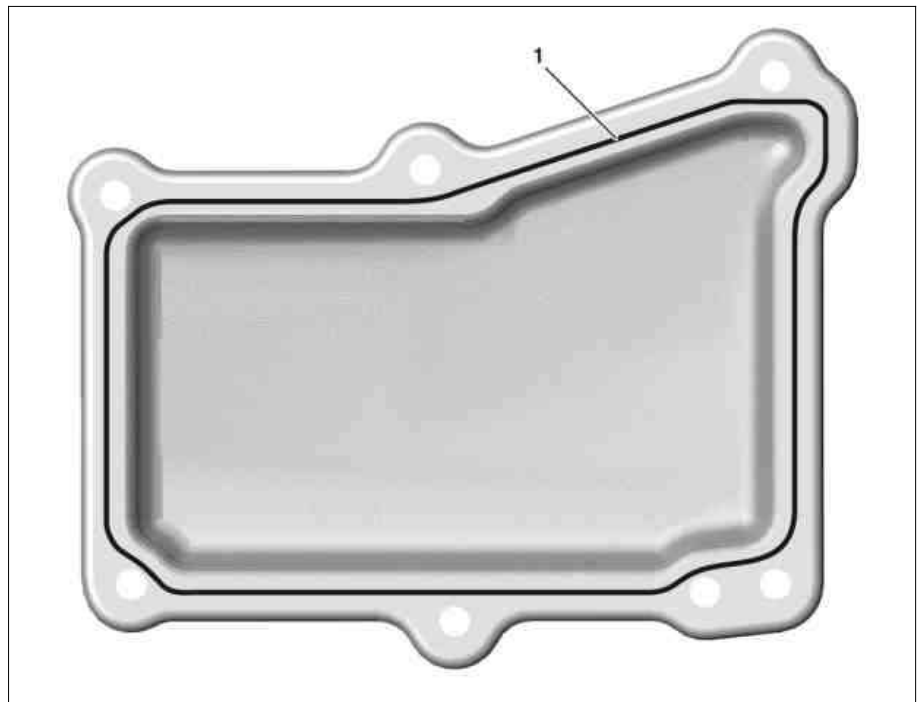

P01.45-2283-06

Oil pan top section on engine 272 with middle sump

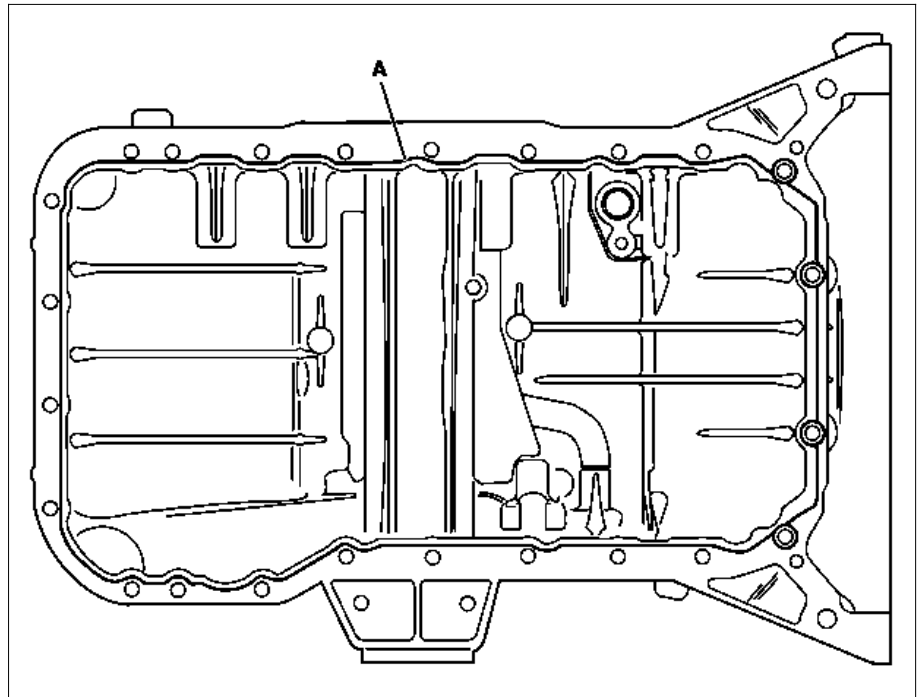

P01.45-2269-06

Oil pan bottom section for engine with rear sump

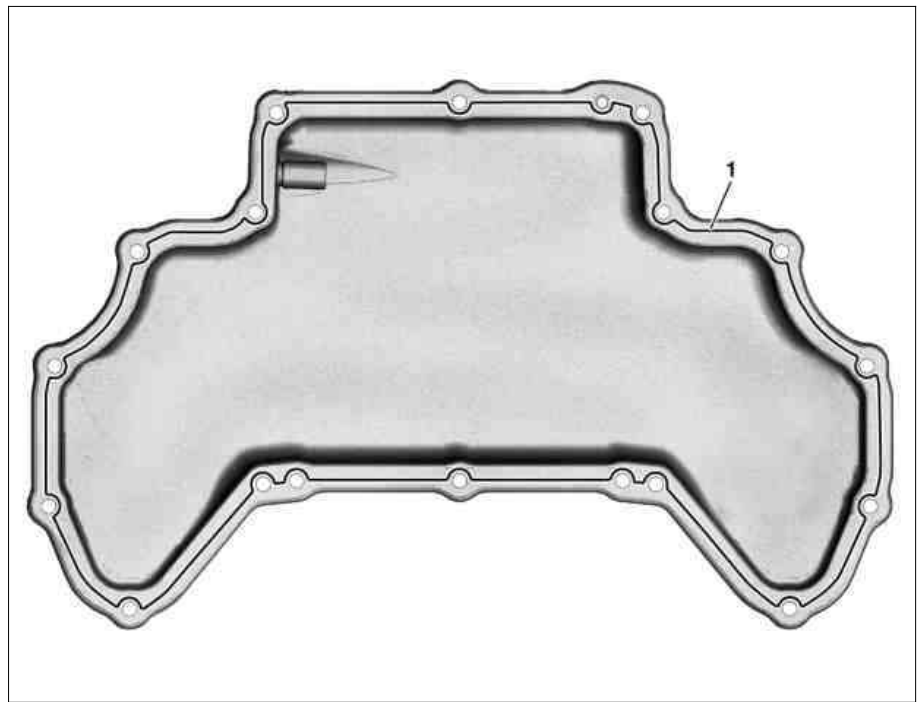

P01.45-2138-06

Oil pan top section on engine 272 with rear sump

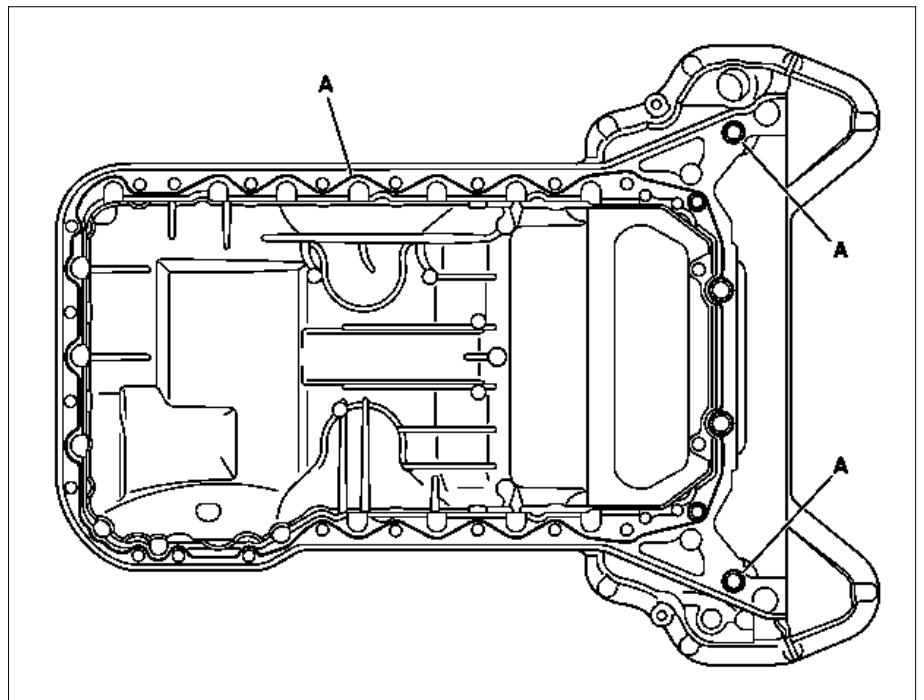

P01.45-2276-06

Engine 273 with code M005

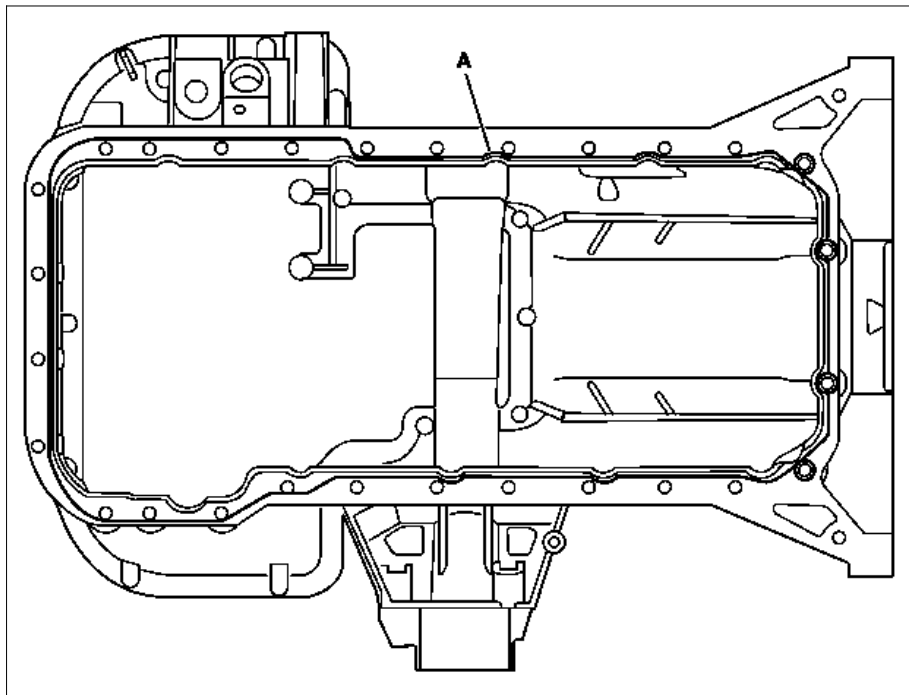

P01.45-2270-06

Oil pan in engine 273 with front sump

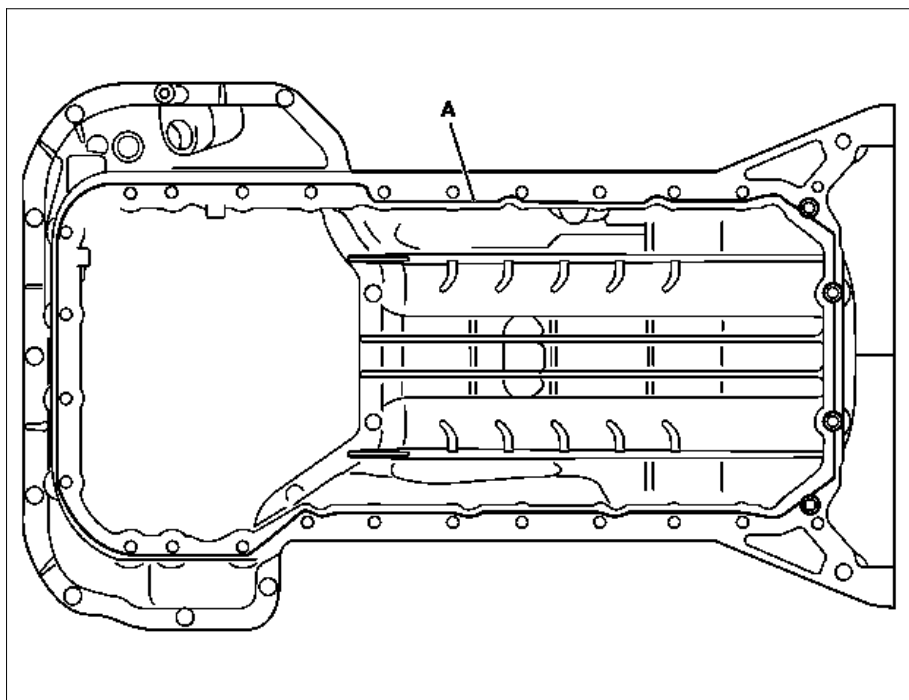

P01.45-2274-06

Oil pan in engine 273 with rear sump

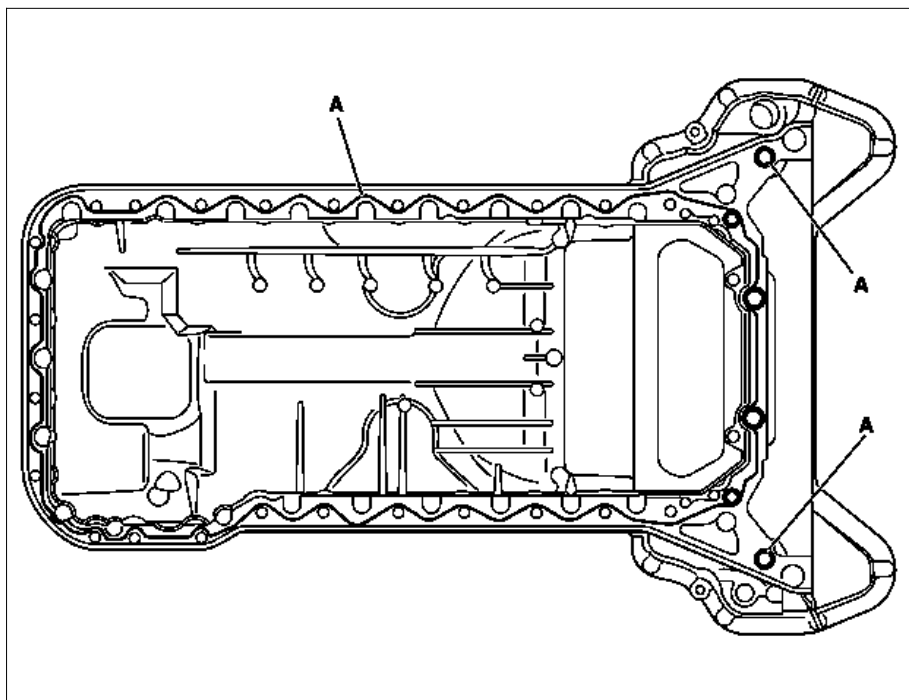

P01.45-2273-06

Oil pan in engine 273 with middle sump

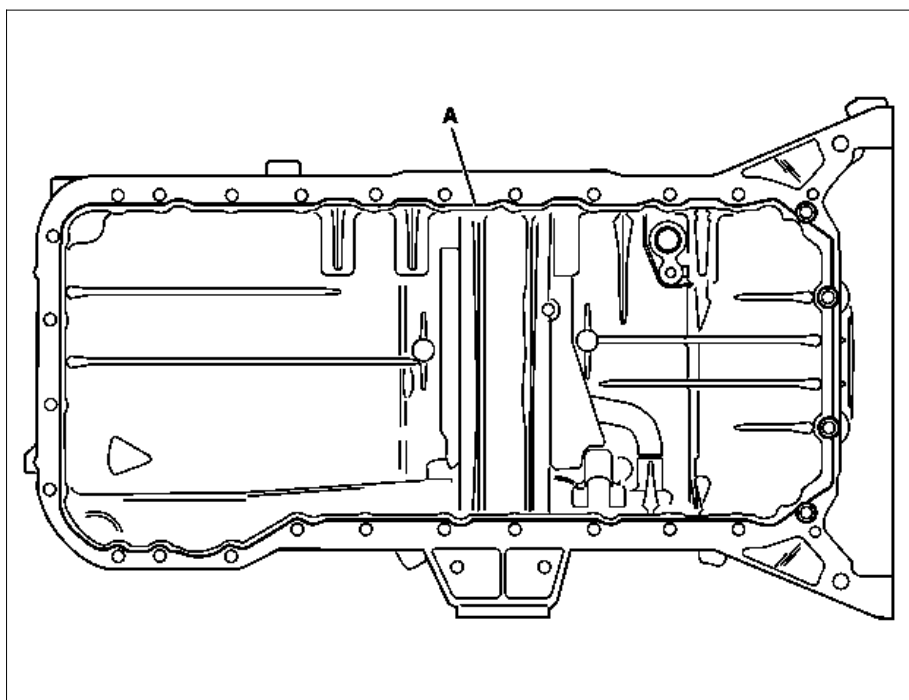

P01.45-2271-06