

MODEL 164, 251

- 1 Wheel carrier
- 9 Rear axle shaft flange
- 9n Wheel bearings
- 11 Retaining ring

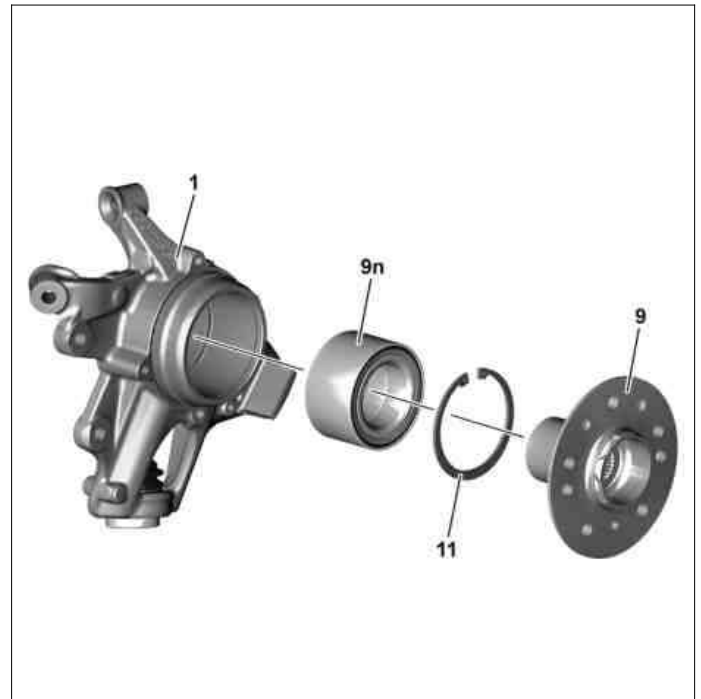

P35.20-2233-12

☒ ☒	Remove/install		
1	Remove wheel carrier (1)	MODEL 251.0/1 MODEL 164	AR35.20-P-0115RT AR35.20-P-0115GZ
2	Pull out rear axle shaft flange (9)	<p>i Installation: The rear axle shaft flange (9) and wheel bearing (9n) must generally be replaced with new ones.</p> <p><input checked="" type="checkbox"/> Extraction tool</p> <p><input checked="" type="checkbox"/> Extraction and insertion tool</p>	AR35.20-P-0130-08RT *202589044300 *220589064300
3	Remove retaining ring (11)	<p>i Installation: Make sure that the retaining ring (11) is seated correctly in the wheel carrier (1).</p>	
4	Pull wheel bearing (9n) out of wheel carrier (1)	<p>i Installation: Pay attention to installation position. The points or the line on the wheel bearing (9n) must point towards the hub/rotor assembly (1).</p> <p><input checked="" type="checkbox"/> Extractor and insertion tool</p> <p><input checked="" type="checkbox"/> Drift</p>	AR35.20-P-0130-03RT *140589084300 *164589041500
5	Install in the reverse order		

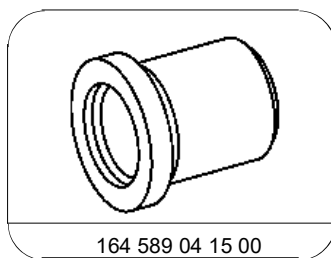

Drift

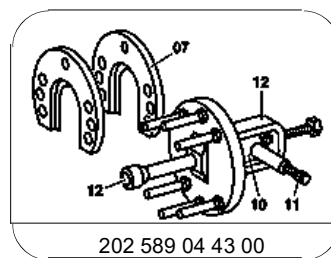

Extraction tool

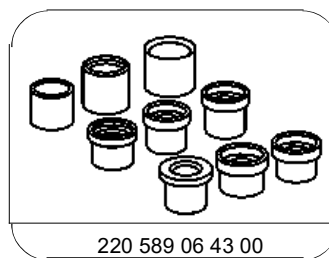

Extraction and insertion tool

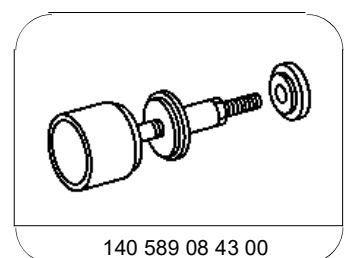

Extractor and insertion tool