

⚠ The tooth flanks (1, 2) are held against each other by spring pressure and should not be skewed, otherwise the camshaft adjuster will be irreparably damaged

- 1 Insert the drift (3, diameter 3mm) into the bore (4) of the cover plate and lock the tooth flanks (1, 2) with each other.
i Push the drift (3) through to the end of tooth flank (2).
To allow the drift (3) to be inserted more easily, align the tooth flanks with each other (in the direction of the arrows).

Shown on camshaft adjuster, engine 273.965

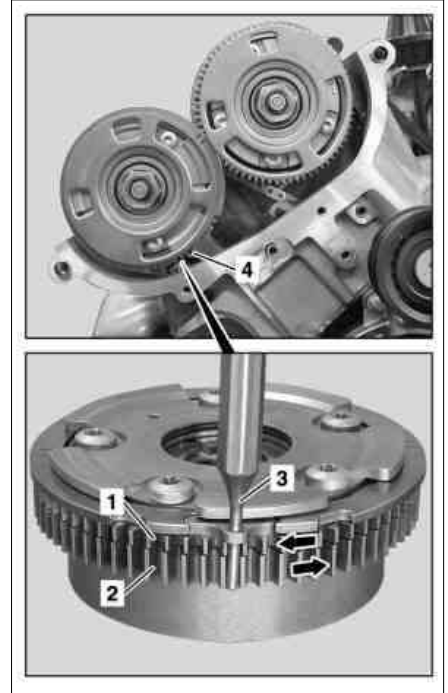

P05.20-2160-03

Shown on camshaft adjuster, engine 272.968



P05.20-2322-01