

P88.20-2632-07

1 Front bumper PTS sensors

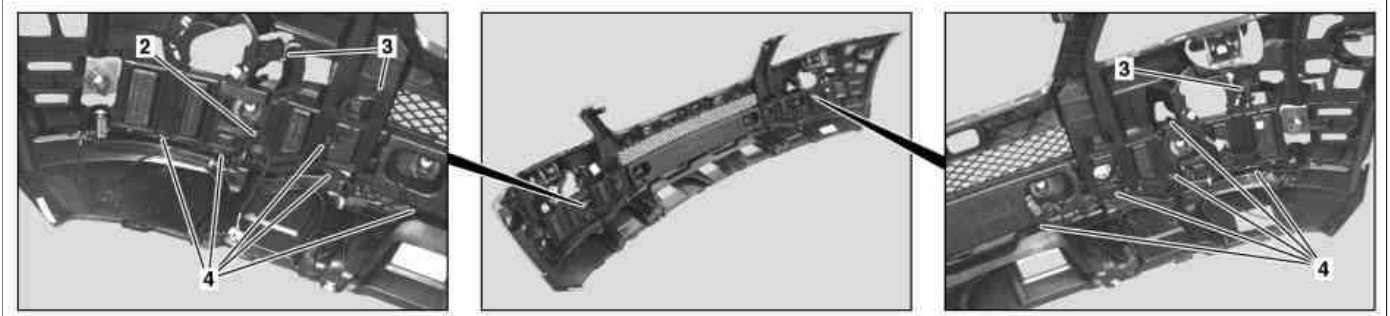

P88.20-2633-07

2 Parktronic wiring harness

3 Electrical connectors

4 Wiring harness clips

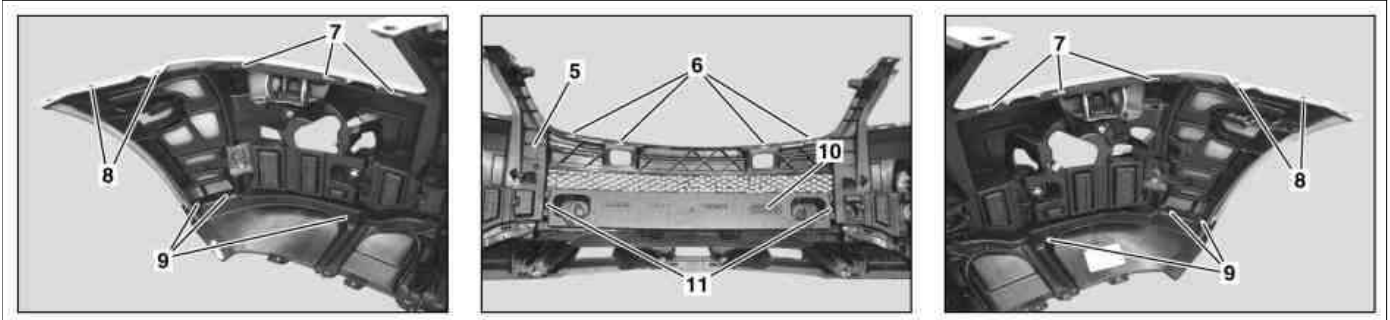

P88.20-2634-07

5 Bumper inside section

6 Clips for inner connection of inside section

7 Clip for outer connection of inside section

8 Expanding rivets

9 Expanding rivets

10 Center impact damper

11 Shackles

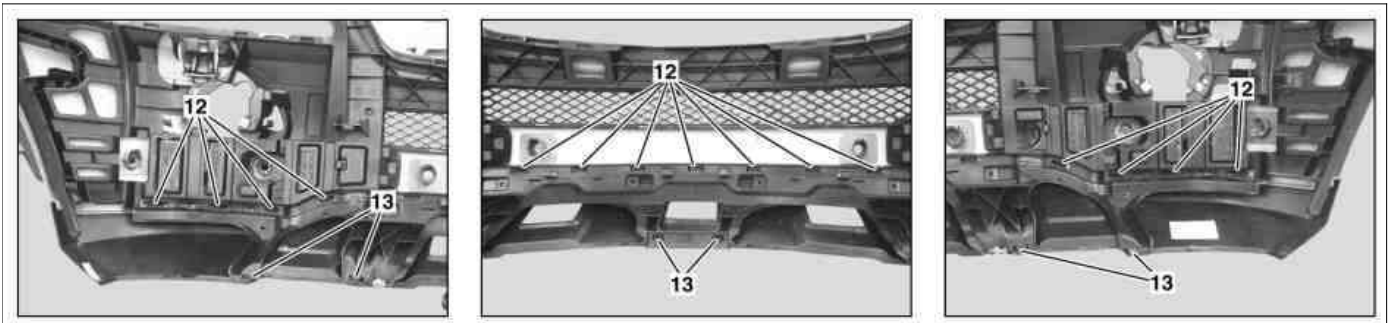

P88.20-2635-07

12 Clip for center connection of inside section

13 Clip for lower connection of inside section

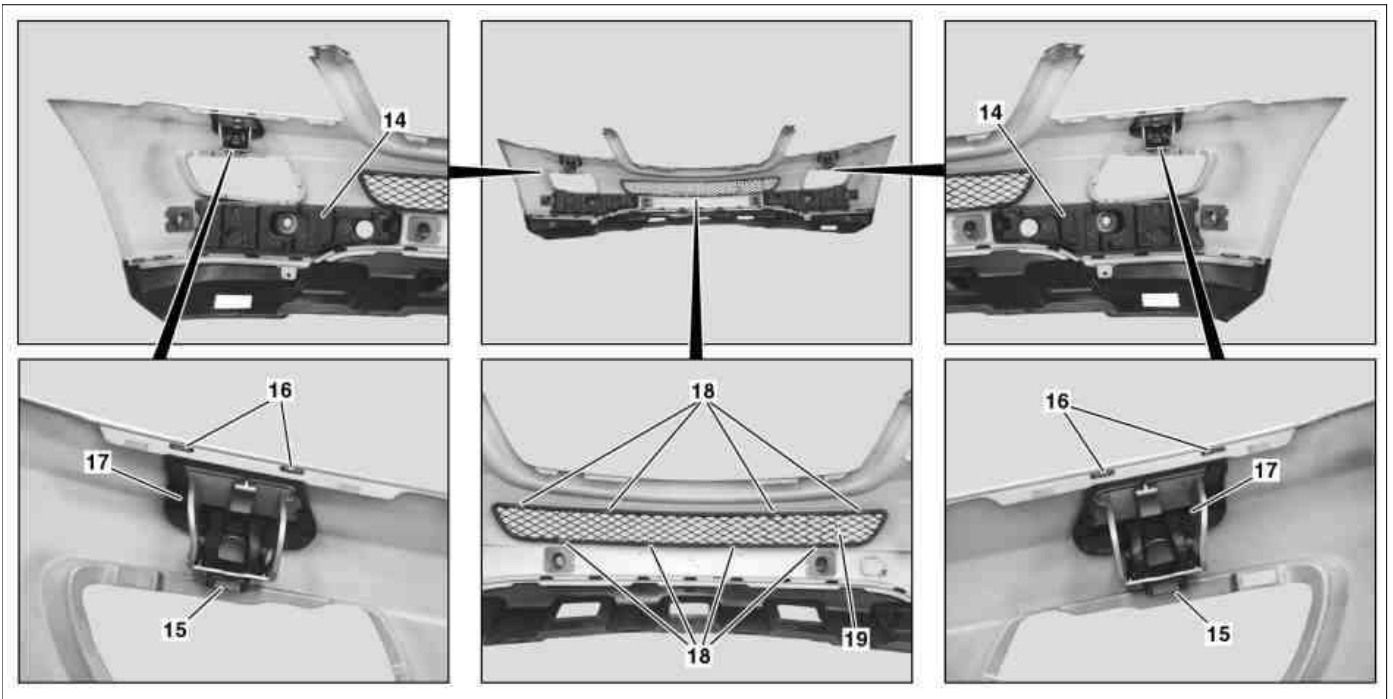

P88.20-2636-09

- 14 Impact absorber
- 15 Clips
- 16 Retaining lug

- 17 Telescopic nozzle cover
- 18 Catch hook
- 19 Air inlet grille

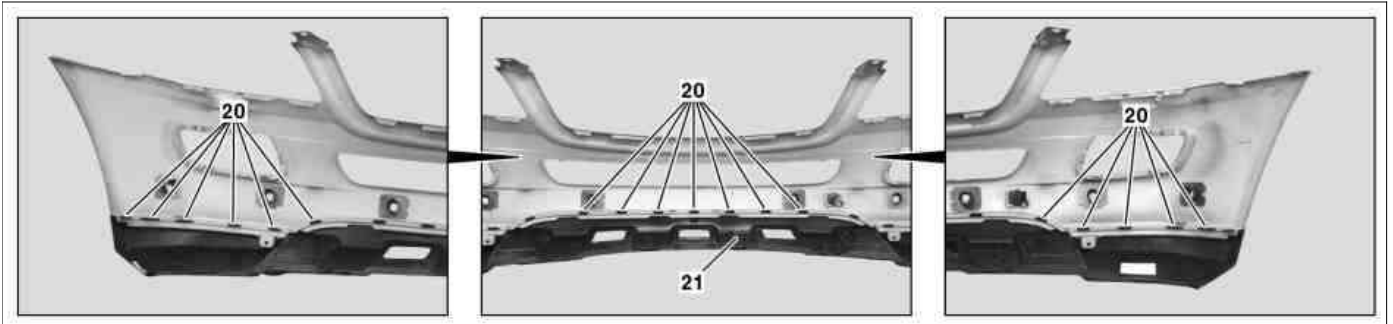

P88.20-2637-07

- 20 Clip for connection of lower section
- 22 Inside section

- 21 Bumper lower section

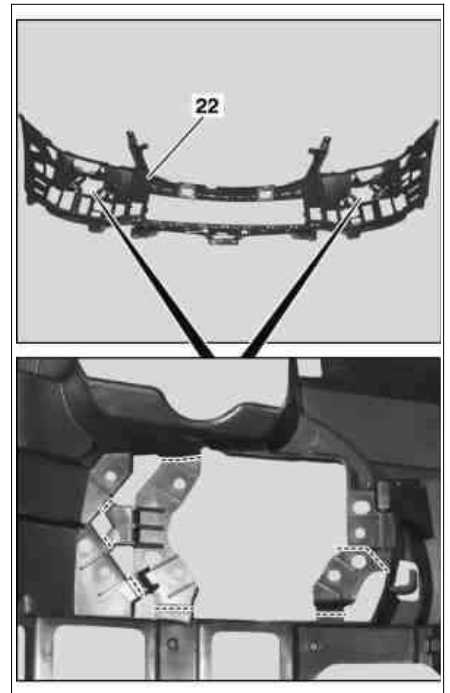

P88.20-3209-03

**Modification notes**

10.4.08	"When replacing bumper inside section (5), it is necessary to additionally enlarge the openings in the inside section (22) on vehicles with code (619) Cornering lights."	Step 4	
---------	---	--------	--

	<b>Removing</b>		
1	Remove front fog lamps		AR82.10-P-5103GZ
2	Remove front bumper		AR88.20-P-2000GZ
	<b>Disassemble/assemble</b>		
3	Unclip front bumper PTS sensors (1) from bumper paneling	Unlocking tool	*168589023100
4	Remove Parktronic wiring harness (2) from bumper inside section (5)	<p> <b>Installation:</b> Route Parktronic wiring harness (2) into corresponding recesses.</p> <p> <b>When replacing bumper inside section (5):</b> On vehicles with code (619) Cornering lights, it is necessary to additionally enlarge the openings in the inside section (22).</p>	
5	Unclip clips for inner connection of inside section (6) from bumper paneling		
6	Unclip clips for outer connection of inside section (7) from bumper paneling		
7	Remove expansion rivets (8, 9) from bumper paneling		
8	Lift shackles (11) and remove center impact absorber (10)		
9	Unclip clips for center connection of inside section (12) from bumper paneling		
10	Unclip clips for lower connection of inside section (13) from bumper paneling		
11	Remove bumper inside section (5)		
12	Remove impact absorber (14) on left and right from bumper paneling	The impact absorber (14) is arrested with a retaining lug	
13	Remove clips (15) and remove left and right telescoping nozzle cover (17) from bumper paneling	<b>Installation:</b> Ensure that retaining lugs (16) are seated correctly in bumper paneling.	
14	Unclip air inlet grate (19) on catch hook (18) from bumper paneling and remove	Mounting wedge	*110589035900
15	Lift clips for connection of lower section (20) and remove bumper lower section (21) from bumper paneling		
16	Assemble in the reverse order		
	<b>Install</b>		
17	Install front bumper		AR88.20-P-2000GZ
18	Install front fog lamps		AR82.10-P-5103GZ

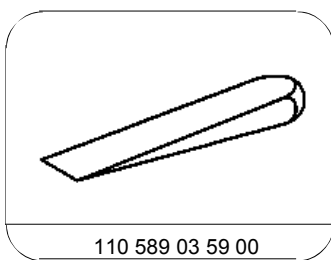

Mounting wedge

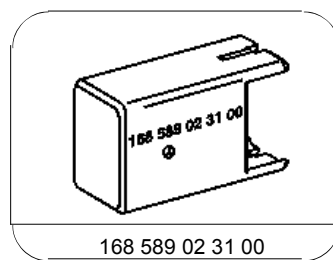

Unlocking tool