

MODEL 164 with CODE (581) Comfort automatic air conditioning

MODEL 166

- 1 Combination filter housing
- 2 Cover
- 3, 4 Combination filter

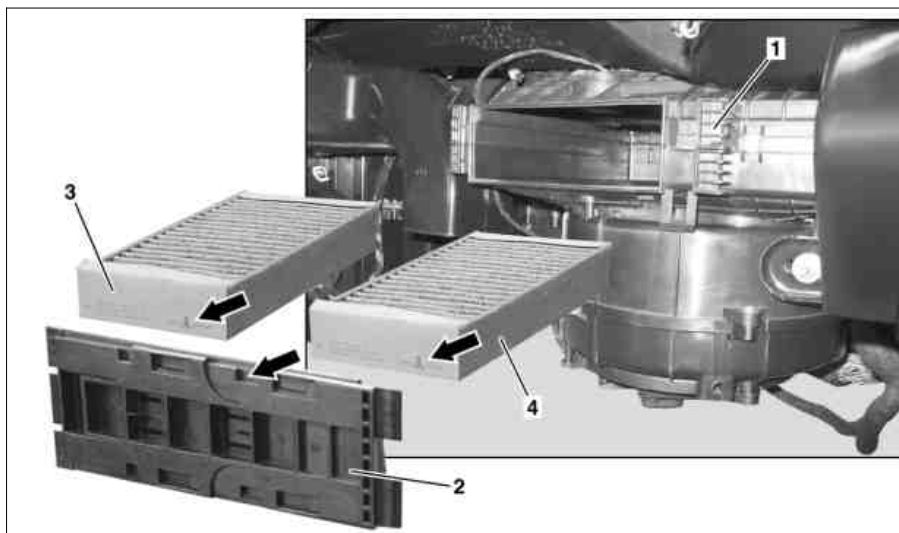

P83.00-2161-05

☒ ☒	Remove/install		
1	Remove glove box	Model 164 Model 166	AR68.10-P-1400GZ AR68.10-P-1400GQ
2	Unlock cover (2) on combination filter housing (1) in direction of the arrow and remove		
3	Remove combination filters (3, 4)	<p>i Installation: Replace combination filters (3, 4), do not clean.</p> <p>i Installation: Observe the installation position (arrows) printed on the combination filters (3, 4).</p>	
4	Install in the reverse order		