

# Automatic transmission 9G-TRONIC 725.0

System description



Mercedes-Benz

# **System description**

## **Automatic transmission 9G-TRONIC 725.0**

### Product Portfolio

You can also find comprehensive information on our complete product portfolio in our Internet portal:  
Link: <http://aftersales.mercedes-benz.com>

### Questions and suggestions

If you have any questions or suggestions concerning this product, please write to us.

Email: [customer.support@daimler.com](mailto:customer.support@daimler.com)

Fax: +49 (0) 69-95 30 73-76

© 2013 by Daimler AG

This document, including all its parts, is protected by copyright. Any further processing or use requires the previous written consent of Daimler AG, Department GSP/OR, D-70546 Stuttgart. This applies in particular to reproduction, distribution, alteration, translation, microfilming and storage and/or processing in electronic systems, including databases and online services.

Image no. of title image: P27.00-2391-00

Image no. Poster: P27.10-2501-00

Order no. of this publication: HLI 000 000 12 33

Preface	4
<b>Overall system</b>	
Overview	5
Sectional view	6
Block diagram	8
Technical data	10
Hydraulic diagram	11
<b>Subsystems</b>	
Electrohydraulic control	13
Shift valve housing and valve block	17
Cover/shift valve housing	18
Rpm sensor system	19
Power transmission/power flow	21
Upshift and downshift	23
Oil supply	24
Driver information	26
Limp-home mode	28
<b>System components</b>	
Torque converter	29
Torque converter lockup clutch	31
Planetary gear set	32
Multidisk clutch	34
Multidisk brake	35
Park pawl	36
Park pawl control	38
Transmission oil cooling	43
Electric transmission oil pump	44
Oil pan and oil filter	46
<b>Service Information</b>	
Flashing	47
<b>Special tools</b>	
Special tools	48
<b>Questions and answers</b>	
Questions about the 9G-TRONIC 725.0 automatic transmission	50
<b>Annex</b>	
Abbreviations	52
Index	53

### **Dear Reader,**

This system description presents the new automatic transmission 9G-TRONIC 725.0. The purpose of this brochure is to acquaint you with the technical highlights of this new transmission in advance of its market launch. This brochure is intended to provide information for people employed in service or maintenance/repair as well as for after-sales staff. It is assumed here that the reader is already familiar with the Mercedes-Benz transmissions currently on the market.

In terms of the contents, the emphasis in this system description is on presenting new and modified components and systems.

This system description is not intended as an aid for repairs or for the diagnosis of technical problems. For such needs, more extensive information is available in the Workshop Information System (WIS) and Xentry Diagnostics.

WIS is updated continuously. Therefore, the information available there reflects the latest technical status of our vehicles.

The system description provides initial information about the new automatic transmission 9G-TRONIC 725.0. The system description is not stored in this form in WIS. The contents of this brochure are not updated. No provision is made for supplements.

We will publicize modifications and new features in the relevant WIS documents. The information presented in this system description may therefore differ from the more up-to-date information found in the WIS.

All of the information relating to specifications, equipment and options are valid as of the copy deadline in June 2013 and may therefore differ from the current production configuration.

### **Daimler AG**

Technical Information and Workshop Equipment (GSP/OR)

The automatic transmission 9G-TRONIC 725.0 is an entirely new electronically controlled automatic transmission with 9 forward gears and one reverse gear. The ratios for the gear stages are achieved by planetary gear sets. All the transmission functions and control components for this automatic transmission are combined in one assembly module. The fully integrated transmission controller unit located in the automatic transmission allows the number of interfaces to the wiring harness in the vehicle to be minimized.

The use of the new fully integrated transmission control (VGS) system also provides the following additional advantages:

- Good electromagnetic compatibility (avoidance of mutual influence between various electronic components)
- Fast current control and compensation of fluctuations in the on-board electrical system, resulting in increased shift quality
- Precise determination of gearshift-relevant measurement values and quicker evaluation of these measurement values

An increased service life, reduced fuel consumption and maximum shift comfort are achieved through:

- A new transmission concept with 9 gears and a gear ratio spread of 9
- New optimized transmission components
- Reduced working pressure
- The implementation of completely new software with additional comfort and dynamic functions
- New actuator concept with two pumps

The transmission can be subdivided into the following assemblies:

- Torque converter with torsional damper, centrifugal pendulum and torque converter lockup clutch
- New oil pump (primary pump) with off-axis design for generating the required oil pressure and for guaranteeing lubrication of shift elements and bearing points
- Electric transmission oil pump for generating the required oil pressure and for guaranteeing lubrication of shift elements and bearing points with the engine off and for supporting the primary pump
- Transmission housing with mechanical transmission components (planetary gear sets, electrohydraulically actuated park pawl, multidisk clutches and multidisk brakes)
- Fully integrated transmission controller unit with integrated fully integrated transmission control unit

Model series	Model	Engine	Transmission	Market launch
E 350 BlueTEC	212.026	642.852	725.011	09/13
E 350 BlueTEC	212.226	642.852	725.011	09/13

Sectional view

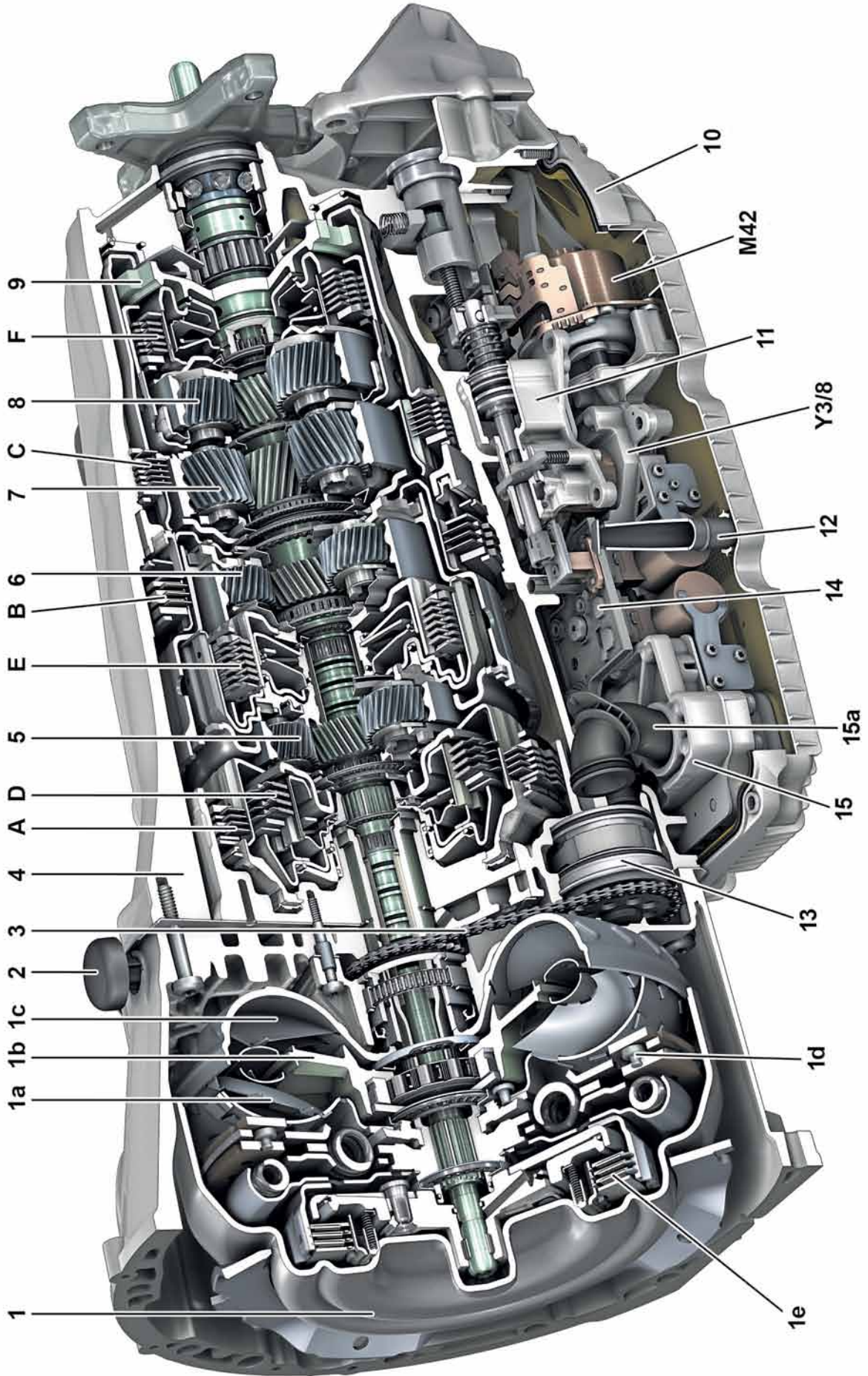

P27.10.2467-00

### Sectional view of automatic transmission 725.0

1	Torque converter cover
1a	Turbine wheel
1b	Stator
1c	Impeller
1d	Centrifugal pendulum
1e	Torque converter lockup clutch
2	Transmission housing ventilation
3	Oil pump drive chain
4	Transmission housing
5	Planetary gear set 1
6	Planetary gear set 2
7	Planetary gear set 3
8	Planetary gear set 4
9	Park pawl gear
10	Oil pan
11	Piston housing for electrohydraulic park pawl actuation
12	Guide tube
13	Oil pump
14	Supporting body of VGS
15	Cover/shift valve housing
15a	Pressure and intake pipes

A	Multidisk brake B08
B	Multidisk brake B05
C	Multidisk brake B06
D	Multidisk clutch K81
E	Multidisk clutch K38
F	Multidisk clutch K27
M42	Electric transmission oil pump
Y3/8	Fully integrated transmission controller unit



Block diagram

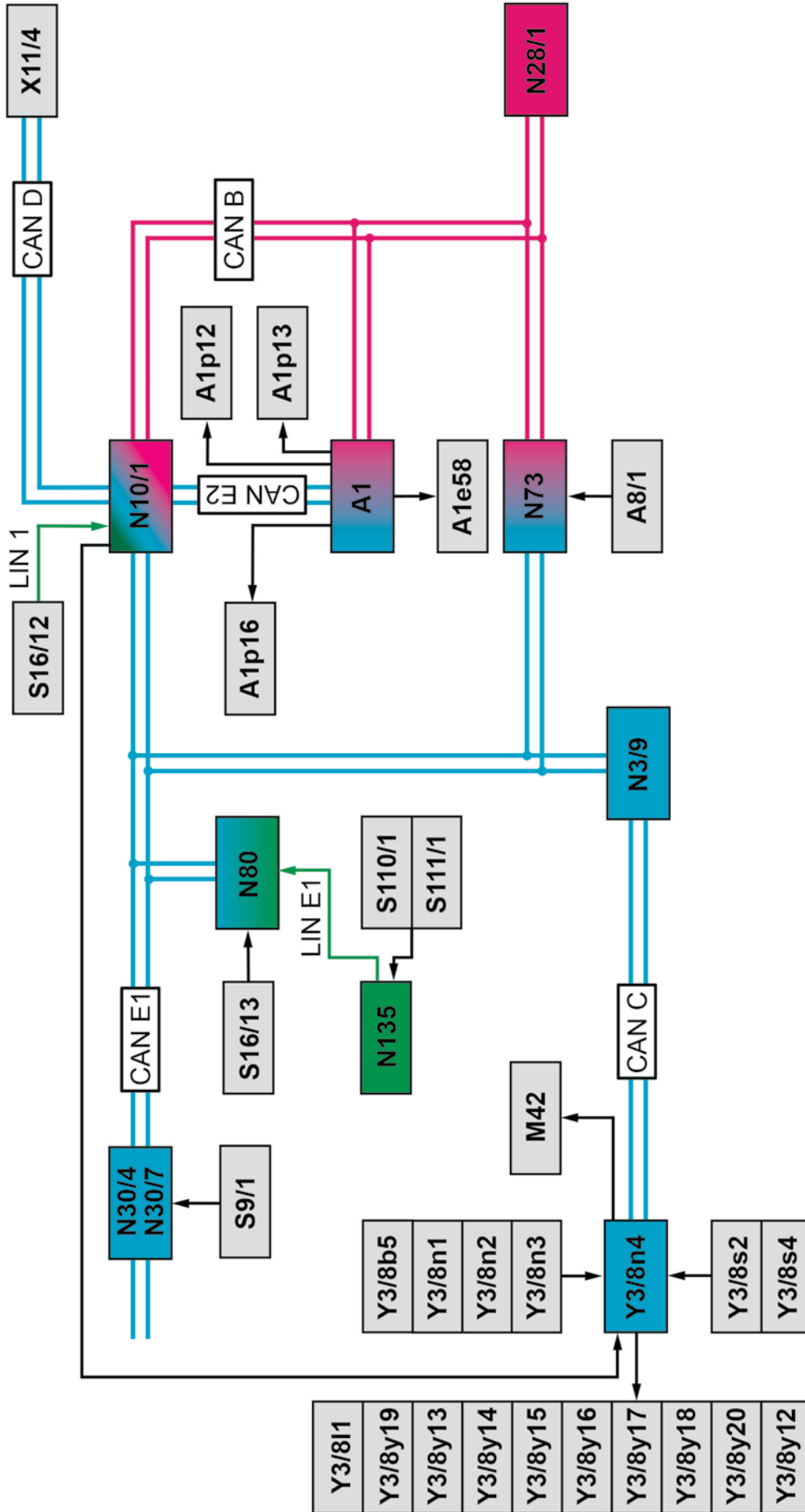

P27.19-2626-00

Block diagram	
A1	Instrument cluster
A1e58	Engine diagnosis indicator lamp
A1p12	Gear indicator
A1p13	Multifunction display
A1p16	Transmission mode display
A8/1	Transmitter key
CAN B	Interior CAN
CAN C	Drive train CAN
CAN D	Diagnostic CAN
CAN E1	Chassis CAN 1
CAN E2	Chassis CAN 2
LIN 1	Instrument panel LIN
LIN E1	Steering LIN
M42	Electric transmission oil pump
N3/9	CDI control unit
N10/1	Front SAM control unit with fuse and relay module
N28/1	Trailer recognition control unit (with CODE 550 (Trailer hitch))
N30/4	Electronic Stability Program control unit (except code (233) DISTRONIC PLUS)
N30/7	Premium Electronic Stability Program control unit (with code (233) DISTRONIC PLUS)
N73	Electronic ignition lock control unit
N80	Steering column tube module control unit
N135	Steering wheel electronics
S9/1	Brake light switch
S16/12	Automatic transmission transmission mode button
S16/13	DIRECT SELECT lever
S110/1	Steering wheel downshift button
S111/1	Steering wheel upshift button
X11/4	Diagnostic connector
Y3/8b5	Pressure sensor
Y3/8I1	Park pawl lift solenoid
Y3/8n1	Turbine wheel rpm sensor
Y3/8n2	Internal transmission rpm sensor
Y3/8n3	Output shaft rpm sensor
Y3/8n4	Fully integrated transmission control unit
Y3/8s2	Transmission oil temperature sensor
Y3/8s4	Park pawl position sensor
Y3/8y12	Lubricating pressure solenoid
Y3/8y13	Clutch control solenoid K81
Y3/8y14	Clutch control solenoid K38
Y3/8y15	Clutch control solenoid K27
Y3/8y16	Multidisk brake control solenoid B08
Y3/8y17	Multidisk brake control solenoid B05
Y3/8y18	Multidisk brake control solenoid B06
Y3/8y19	Working pressure solenoid
Y3/8y20	Torque converter lockup clutch solenoid

## Technical data

Automatic transmission	Unit	725.011
Designation		W9A 700
Shift mechanism		9-speed, automatic
Number of ratios		9+R
Gear ratio spread		9.150
Weight of automatic transmission (including torque converter and transmission oil)	kg	94.8 (with OM 642)
Automatic transmission fluid (yellow/gold) GTL	l	approx. 10
Max. rpm 1st to 7th gear	rpm	7000
8th gear	rpm	5900
9th gear	rpm	5000
Overall length	mm	644...649 depending on joint flange and torque converter
Starting device		Hydraulic torque converter
Max. input torque	Nm	700

Transmission ratio		A (B08) <sup>1</sup>	B (B05) <sup>2</sup>	C (B06) <sup>3</sup>	D (K81) <sup>4</sup>	E (K38) <sup>5</sup>	F (K27) <sup>6</sup>
1st gear	5.503		•	•		•	
2nd gear	3.333			•	•	•	
3rd gear	2.315		•	•	•		
4th gear	1.661		•	•			•
5th gear	1.211		•		•		•
6th gear	1.000				•	•	•
7th gear	0.865		•			•	•
8th gear	0.717	•				•	•
9th gear	0.601	•	•				•
Neutral position "N"	-						
Reverse gear "R"	-4.932						

<sup>1</sup> Multidisk brake B08

<sup>2</sup> Multidisk brake B05

<sup>3</sup> Multidisk brake B06

<sup>4</sup> Multidisk clutch K81

<sup>5</sup> Multidisk clutch K38

<sup>6</sup> Multidisk clutch K27

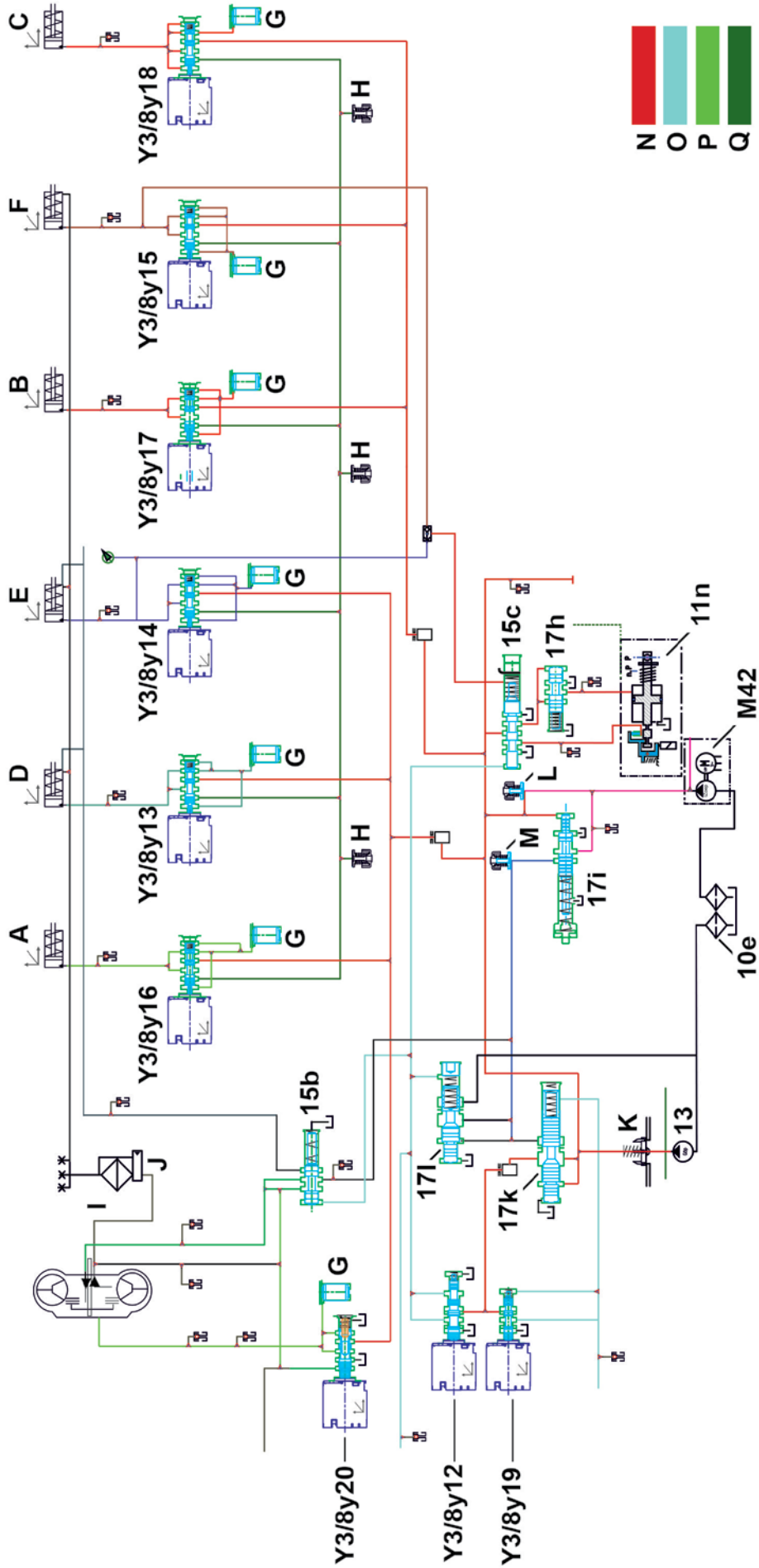

P27.00-2392-00

## Hydraulic diagram

## Hydraulic diagram of automatic transmission 725.0

10e	Oil filter and oil pan	P	Lubricating pressure
11n	Park pawl module	Q	Shift pressure
13	Oil pump	M42	Electric transmission oil pump
15b	Boost shift valve	Y3/8y12	Lubricating pressure solenoid
15c	Park/Not Park regulating valve	Y3/8y13	Clutch control solenoid K81
17h	Not Park shift valve	Y3/8y14	Clutch control solenoid K38
17i	Lubricating pressure shift valve	Y3/8y15	Clutch control solenoid K27
17k	Working pressure regulating valve	Y3/8y16	Multidisk brake control solenoid B08
17l	Lubricating pressure regulating valve	Y3/8y17	Multidisk brake control solenoid B05
A	Multidisk brake B08	Y3/8y18	Multidisk brake control solenoid B06
B	Multidisk brake B05	Y3/8y19	Working pressure solenoid
C	Multidisk brake B06	Y3/8y20	Torque converter lockup clutch solenoid
D	Multidisk clutch K81		
E	Multidisk clutch K38		
F	Multidisk clutch K27		
G	Damper		
H	Pressure holding valves		
I	Transmission cooler		
J	Transmission oil thermostat		
K	Working pressure check valve		
L	Check valve to electric transmission oil pump		
M	Check valve to electric transmission oil pump		
N	Working pressure		
O	Control pressure		

**Fully integrated transmission controller unit**

The fully integrated transmission controller unit is connected to the CAN network of the vehicle and evaluates the incoming signals and requests from other control units, actuating the internal actuators accordingly depending on this information. It also evaluates the signals of the sensor system and forwards them to the associated control units.

The fully integrated transmission control unit actuates the following actuators and/or performs the following functions depending on the sensor and CAN input signals:

- Shift valves and solenoids
- Electric transmission oil pump
- Hydraulic park pawl actuation
- Electrohydraulic park pawl release

**Special features of fully integrated transmission controller unit**

The automatic transmission was conceived as a compact transmission unit for north-south installation. Particular attention was paid to ensuring that all components which are involved in the gearshift, lubrication and control processes are integrated in the transmission.

The special features of the fully integrated transmission controller unit are:

- The electric transmission oil pump
- All shift valves and solenoids are located on the fully integrated transmission controller unit
- The entire sensor system (consisting of rpm, temperature, pressure and position sensors) is part of the fully integrated transmission controller unit
- The fully integrated transmission control unit is integrated in the fully integrated transmission controller unit

## Electrohydraulic control

### Shift pressure, lubricating pressure and working pressure

The oil pressures are separated into:

- Working pressure
- Lubrication pressure
- Shift pressure

### Working pressure

The oil pressure produced by the primary pump is converted into working pressure by the working pressure regulating valve.

The level of working pressure depends on the position of the regulating valve and therefore on its geometry.

The position of the working pressure regulating valve is influenced by the working pressure solenoid to match the load and gear. All other oil pressures required for transmission control are derived from the working pressures.

### Lubrication pressure

At the working pressure regulating valve excess oil is diverted to the lubrication pressure regulating valve and from there used in a regulated manner for lubrication and cooling of mechanical transmission parts and the torque converter. In addition, the oil pressure in the torque converter is limited via regulation of the lubrication pressure.

### Shift pressure

The shift pressure (oil pressure in the multidisk clutch or multidisk brake) is derived from the working pressure.

The respective solenoid influences the position of the associated regulating valve. In turn, the position influences the oil pressure prevailing in the multidisk brake or multidisk clutch. The shift pressure thus depends on the geometry of the respective regulating valve.

### Electric transmission oil pump

The electric transmission oil pump provides the hydraulic system's oil supply when the internal combustion engine is switched off. It is actuated through the fully integrated transmission control unit.

#### **i** Note

The actively controlled lubricating pressure reduction function causes a reduction in drag and thus reduces fuel consumption.

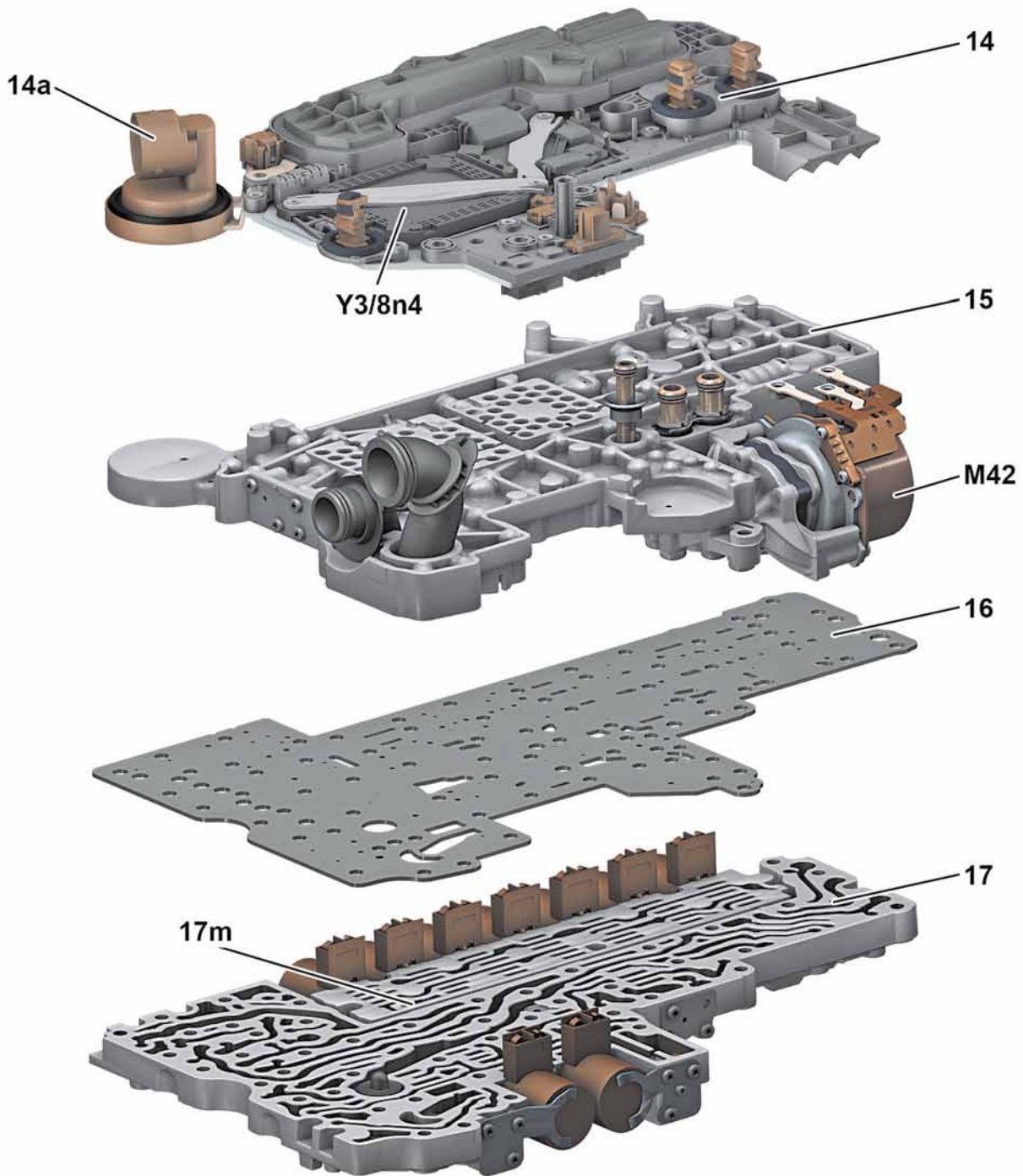

#### Exploded view of electrohydraulic actuator (EHS)

P27.60-3652-00

14	Supporting body of VGS
14a	Transmission connector
15	Cover/shift valve housing
16	Intermediate panel
17	Shift valve housing
17m	Valve block
M42	Electric transmission oil pump
Y3/8n4	Fully integrated transmission control unit



## Electrohydraulic control

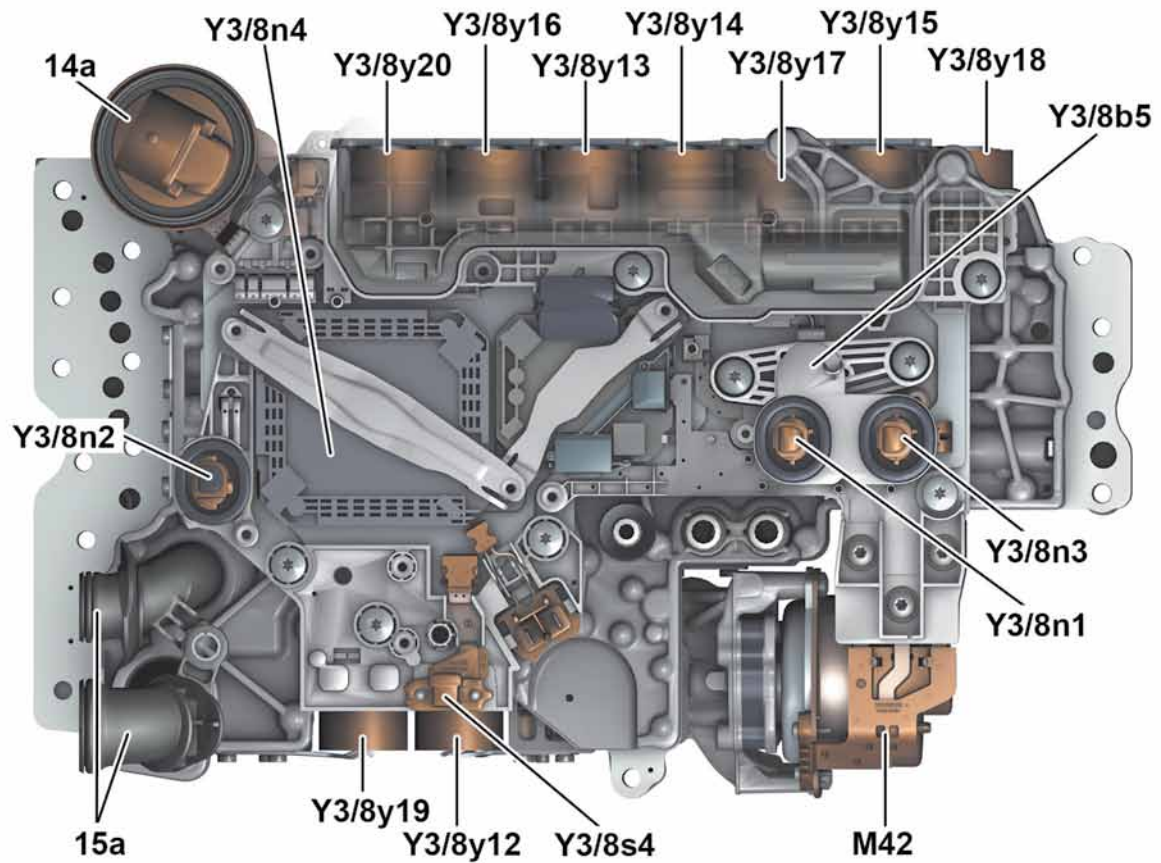

## Components of EHS

14a	Transmission connector	Y3/8y13	Clutch control solenoid K81
15a	Pressure and intake pipes	Y3/8y14	Clutch control solenoid K38
M42	Electric transmission oil pump	Y3/8y15	Clutch control solenoid K27
Y3/8b5	Pressure sensor	Y3/8y16	Multidisk brake control solenoid B08
Y3/8n1	Turbine wheel rpm sensor	Y3/8y17	Multidisk brake control solenoid B05
Y3/8n2	Internal transmission rpm sensor	Y3/8y18	Multidisk brake control solenoid B06
Y3/8n3	Output shaft rpm sensor	Y3/8y19	Working pressure solenoid
Y3/8n4	Fully integrated transmission control unit	Y3/8y20	Torque converter lockup clutch solenoid
Y3/8s4	Park pawl position sensor		
Y3/8y12	Lubricating pressure solenoid		

P27.19-2624-00

**Note**

The rpm sensors are permanently connected to the fully integrated transmission controller unit and cannot be replaced individually.

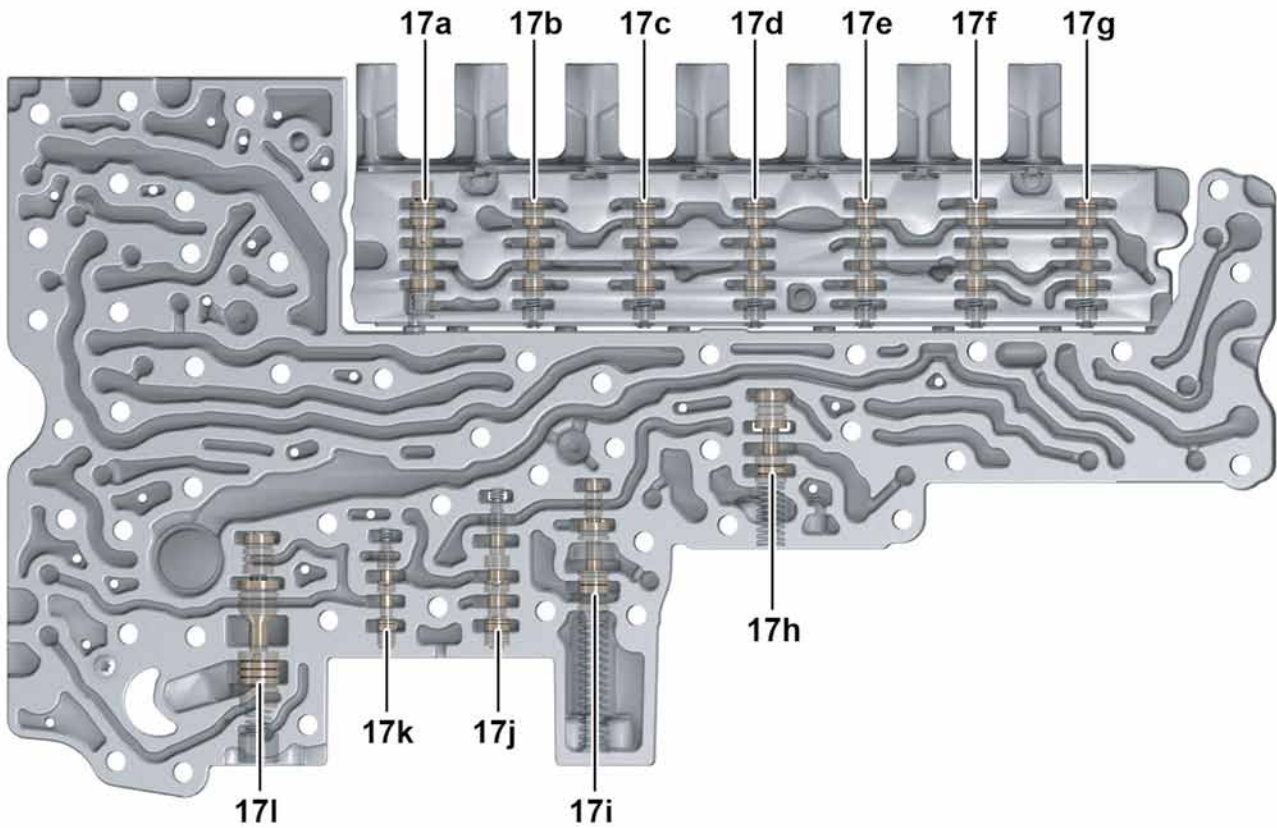

Shift valve housing

P27.35-2013-00

17a	WÜK regulating valve	17g	Brake regulating valve B06
17b	Brake regulating valve B08	17h	Not Park shift valve
17c	Clutch regulating valve K81	17i	Lubricating pressure shift valve
17d	Clutch regulating valve K38	17j	Lubricating pressure solenoid regulating valve
17e	Brake regulating valve B05	17k	Working pressure regulating valve
17f	Clutch regulating valve K27	17l	Lubricating pressure regulating valve

## Cover/shift valve housing

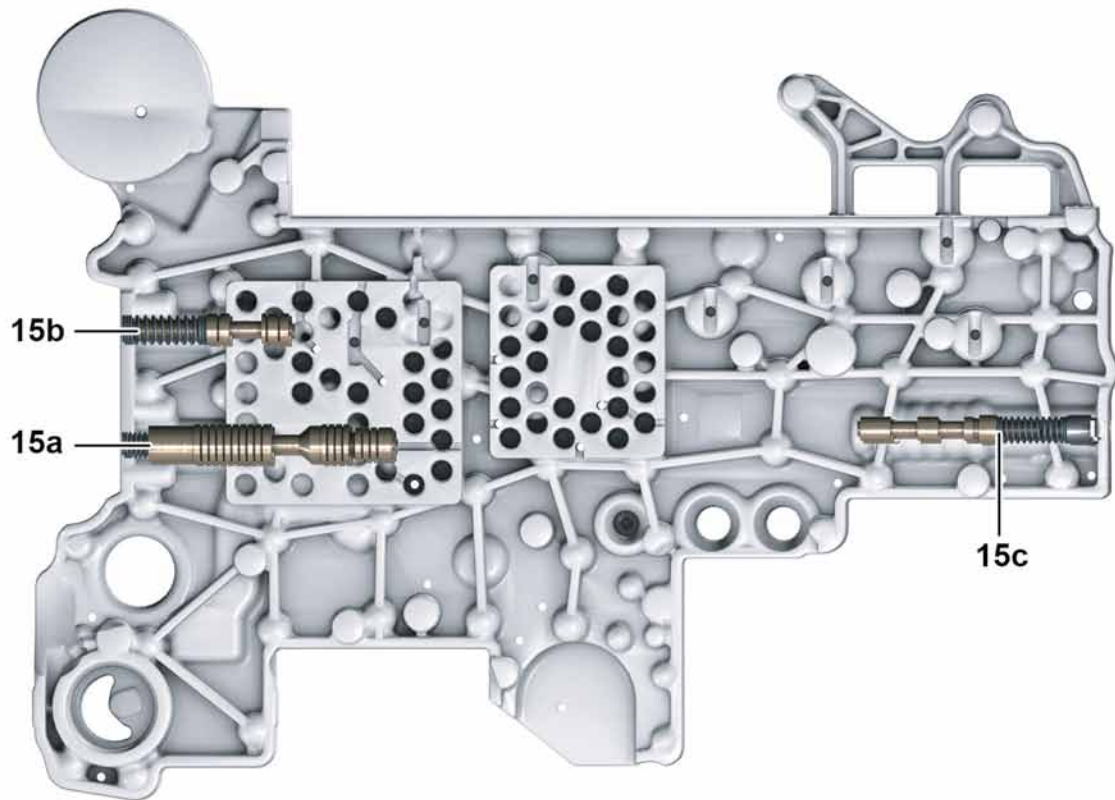

## Cover/shift valve housing

- 15a Working pressure regulating valve
- 15b Boost shift valve (supports centrifugal oil cover filling)
- 15c Park/Not Park shift valve

P27.10-2468-00

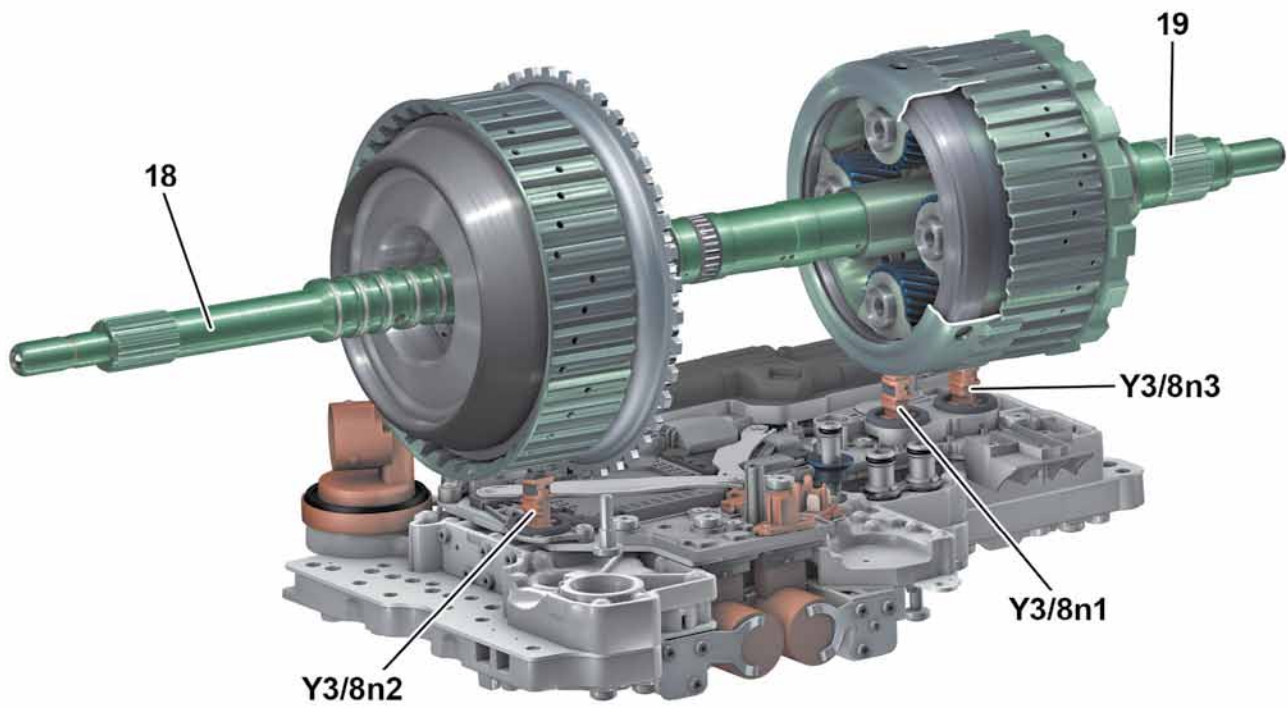

## Rpm sensors

18	Drive shaft	Y3/8n2	Internal transmission rpm sensor
19	Output shaft	Y3/8n3	Output shaft rpm sensor
Y3/8n1	Turbine wheel rpm sensor		

P27.19-2625-00

## Rpm sensor system

### Internal transmission speed rpm sensor

The internal transmission rpm is recorded by an active sensor (differential Hall sensor with integrated magnet). External plate carrier K81 is used as a passive sensor element for the internal rpm.

### Turbine wheel rpm sensor

The turbine wheel speed is recorded by passive sensor (differential Hall sensor). A pole wheel is used as an active sensor element for the turbine speed. It is pressed onto the planet carrier of planetary gear set P4.

### Output shaft rpm sensor

The output speed is recorded by an active sensor with rotation direction detection (differential Hall sensor with integrated magnet). External plate carrier K27 is used as a passive sensor element for the output speed. It is welded to the output shaft.

#### Note

All sensors are permanently connected to the fully integrated transmission controller unit and cannot be replaced individually. In the first 6 to 8 months as of market launch, the entire EHS must be replaced.

### Transfer of torque

The engine torque is transferred from the crankshaft to the torque converter, the downstream automatic transmission and via the rear axle differential to the drive wheels. Power is transferred in the torque converter via the driven impeller by diverting hydraulic fluid to the turbine wheel which is connected to the drive shaft. When the torque converter lockup clutch is engaged, power is transmitted via this mechanical connection. Via the gear wheels of the individual planetary gear sets, the torques coming from the converter, depending on the gear ratio and shift elements actuated, are passed on to the output shaft with the help of the multidisk clutches and multidisk brakes. A reduction of the output speed in the low gears provides lower vehicle speeds with high tractive forces and drive torques at the drive wheels.

### Power flow illustrated based on 1st gear

#### Function sequence of power flow in 1st gear

The following multidisk brakes and multidisk clutches are engaged:

- Multidisk brake B05
- Multidisk brake B06
- Multidisk clutch K38

In 1st gear, the power flows through the following gear sets:

- Planetary gear set P1
- Planetary gear set P2
- Planetary gear set P3

The sun gear of planetary gear set P1 is part of the drive shaft and is driven by it. The planet carrier of planetary gear set P1 is connected to the ring gear of planetary gear set P2 via multidisk clutch K38. Multidisk brake B05 brakes the sun gear of planetary gear set P2. This increases the torque and reduces the rpm. The ring gear of planetary gear set P2 has a mechanical connection to the sun gear of planetary gear set P3. The planetary gears roll within the ring gear of planetary gear set P3, which is braked to a standstill by multidisk brake B06, and transfer the resulting increased torque and resulting reduced rpm to the output shaft. The output shaft thus rotates with a reduced transmission input speed in the direction of rotation of the engine.

#### Note

All planetary gear sets consist of the following elements:

- Sun gear
- Planetary gears
- Planet carrier
- Ring gear

## Power transmission/power flow

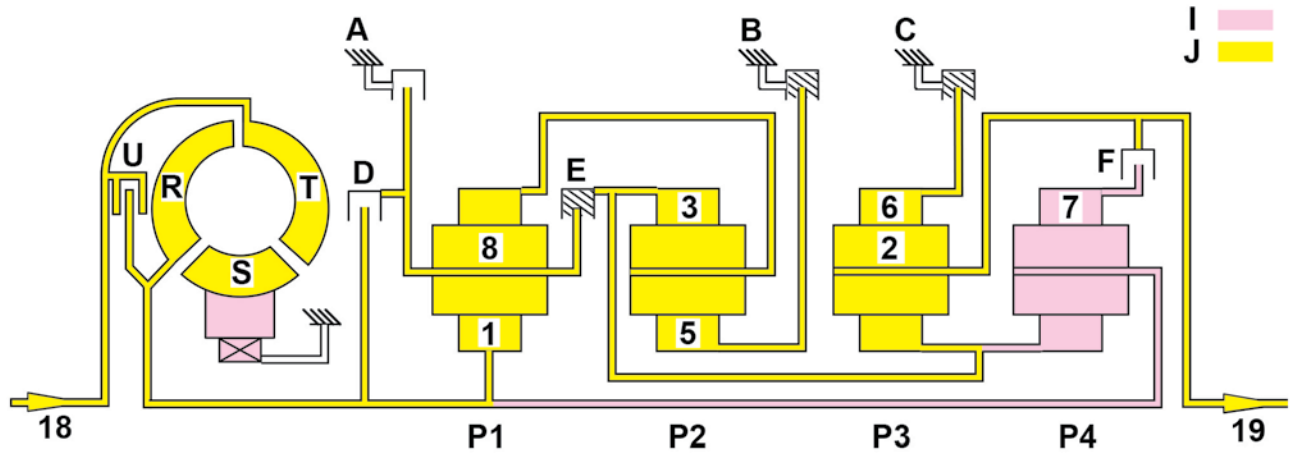

## Power flow in 1st gear

1	Sun gear	E	Multidisk clutch K38
2	Planet carrier	F	Multidisk clutch K27
3	Ring gear	I	Elements not engaged
5	Sun gear	J	Elements engaged
6	Ring gear	P1	Planetary gear set P1
7	Ring gear	P2	Planetary gear set P2
8	Planet carrier	P3	Planetary gear set P3
18	Drive shaft	P4	Planetary gear set P4
19	Output shaft	R	Turbine wheel
A	Multidisk brake B08	S	Stator
B	Multidisk brake B05	T	Impeller
C	Multidisk brake B06	U	Torque converter lockup clutch
D	Multidisk clutch K81		

P27.00-2389-00

### Shift operation

The fully integrated transmission controller unit converts the electrical signals coming from the fully integrated transmission control unit into hydraulic signals. Gear ranges "R", "N", "D1" to "D9" and "P" can be engaged by operating the DIRECT SELECT lever. The DIRECT SELECT lever transfers the information about the selected gear range "P", "R", "N", "D1" to "D9" to the steering column tube module control unit, which places the signal on chassis CAN 1. Here, the signal is registered by the CDI control unit and relayed over the drive train CAN to the fully integrated transmission control unit. The corresponding gear range is engaged. The shift range with gear range "D1" to "D9" engaged is displayed on the instrument cluster. Although the shift range can be changed in the forward gears while driving, the fully integrated transmission control unit prevents a shift operation if the engine speeds are too high or too low.

### Upshift and downshift

In the Sport "S" and Economy "E" transmission modes, the driver can select the following functions by pressing the steering wheel downshift button or steering wheel upshift button:

- Pressing the steering wheel gearshift buttons in transmission mode "E" or "S" activates temporary M mode (KZM). This allows the driver to change gears using the steering wheel gearshift buttons without previously selecting M mode. The previous gear limitation/shift into optimum gear (SOG) function, which was operated by pressing the steering wheel gearshift buttons, has been discontinued.
- In contrast to permanent M mode, KZM is automatically deactivated after a certain period of time. This time interval starts over again each time a button is pressed. In addition, the activity of the function is extended by wide open throttle operation and lateral acceleration.

- "E" transmission mode has a shorter shift range in comparison to "S" transmission mode (shifts at a lower engine speed) and therefore produces a lower drive torque during forward and reverse travel. This results in more economical and comfortable driving, as the gears are not exploited to their limits.
- In Manual "M" transmission mode, the individual gears "1" to "9" can be engaged directly via the steering wheel downshift button or steering wheel upshift button.

The reverse gear and neutral position can only be engaged via the DIRECT SELECT lever. The park pawl (gear range "P") is activated by operating the park pawl on the DIRECT SELECT lever.

Transmission mode "M" is no longer active after a change in status of circuit 15. The transmission then always starts in the default transmission mode.



## Oil supply

### Oil supply

With the combustion engine running, the oil pump (primary pump) delivers oil to the electrohydraulically actuated automatic transmission. The oil pump is driven via a drive chain (off-axis design) by the drive shaft. The oil pump is installed at the bottom of the transmission bell housing behind the torque converter in the external plate carrier.

### Oil supply with combustion engine OFF

If the oil supply fails with the combustion engine off, all the control elements and actuators change to a basic state under no load and the automatic transmission power flow stops.

When the internal combustion engine is started, and the oil supply has been built up, the gear position has to be changed from "N" to "D". The resulting loss of time between the start-off request and the start-off time is minimized unnoticeably by the electric transmission oil pump. The electric transmission oil pump is actuated with the combustion engine off in start/stop mode and then provides the basic supply to the control elements and actuators. A defined basic pressure is thus maintained.

The electric transmission oil pump also supports the primary pump at low internal combustion engine speeds. The

demand-controlled flow provided by the electric transmission oil pump is requested in the low rpm range of the combustion engine during shift operations (filling of actuator) or in the event of increased cooling requirements.

### Transmission housing ventilation

The breather is located on top of the transmission housing. A duct cast into the transmission bell housing connects the interior transmission chamber to the breather.

The transmission housing breather ensures that a pressure equilibrium is maintained in the transmission housing in the event of temperature-related volume changes in the transmission fluid and air.

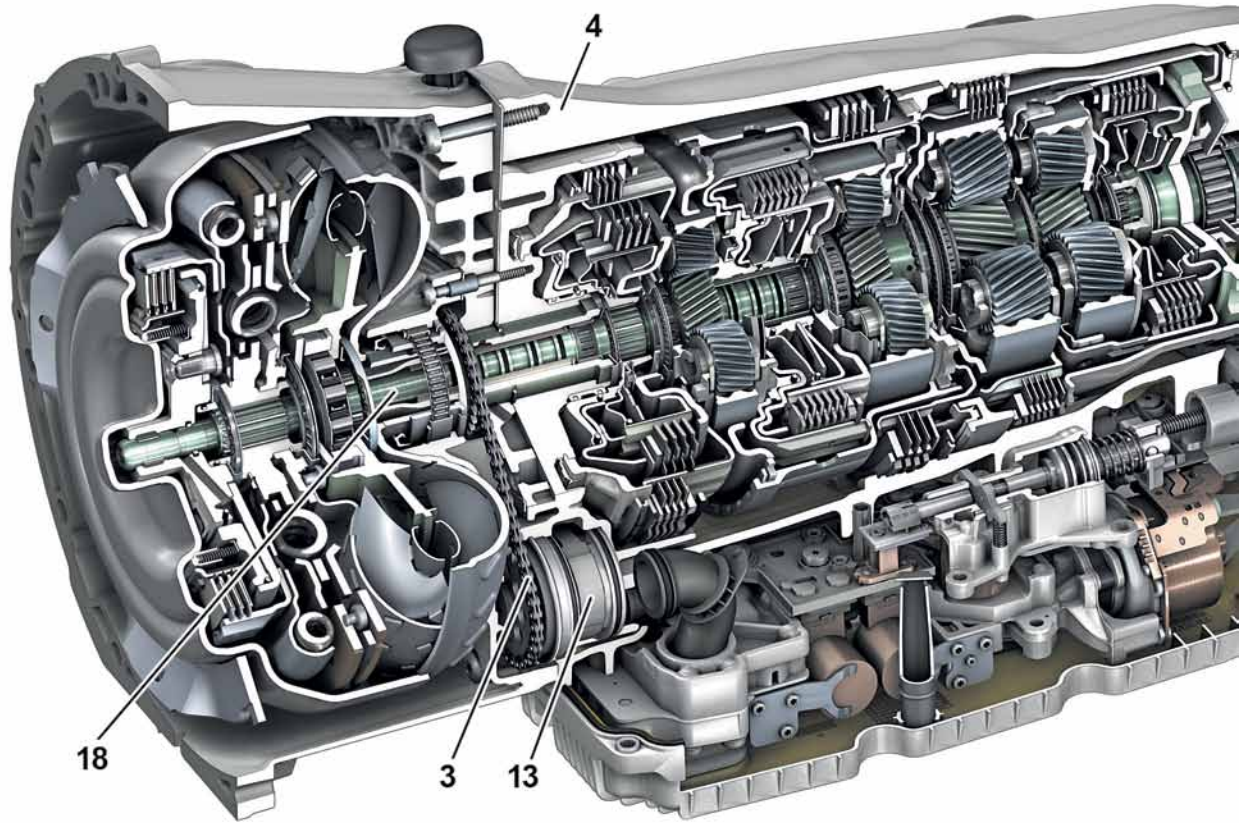

**Oil pump (primary pump)**

- 3 Drive chain
- 4 Transmission housing

- 13 Oil pump
- 18 Drive shaft

P27.57-2037-00

## Driver information

The control and display concept is designed so that the driver has the best possible overview of the current operating condition of all relevant systems at all times and receives all driving information regarding the gear, gear range and transmission mode selections.

### Gear indicator in instrument cluster in Economy transmission mode "E" and Sport transmission mode "S"

This shows the driver the gear currently engaged automatically "D1" to "D9" or the other selector lever positions "R", "N", "P" (selector lever position "D" only if "R", "N" or "P" is engaged).

### Gear indicator in instrument cluster in Manual transmission mode "M"

This shows the driver the gear engaged manually "1" to "9" or the other selector lever positions "R", "N", "P".

### Transmission mode display in instrument cluster

This shows the driver the mode selected on the automatic transmission mode button:

- Economy "E"
- Manual "M"
- Sport "S"

The following selector lever positions are recorded via the DIRECT SELECT lever:

- "R", reverse gear
- "N", neutral and start position (no power transmission, vehicle can move freely)
- "D1 to D9", all 9 forward gears are available

In order to switch from one selector lever position to another, the DIRECT SELECT lever must be pressed over the actuation point (greater level of force required).

Actuating the park pawl on the DIRECT SELECT lever activates the park pawl at a vehicle speed of < 8 km/h.



Center console view

P27.60-3683-00

S16/12 Automatic transmission transmission mode button

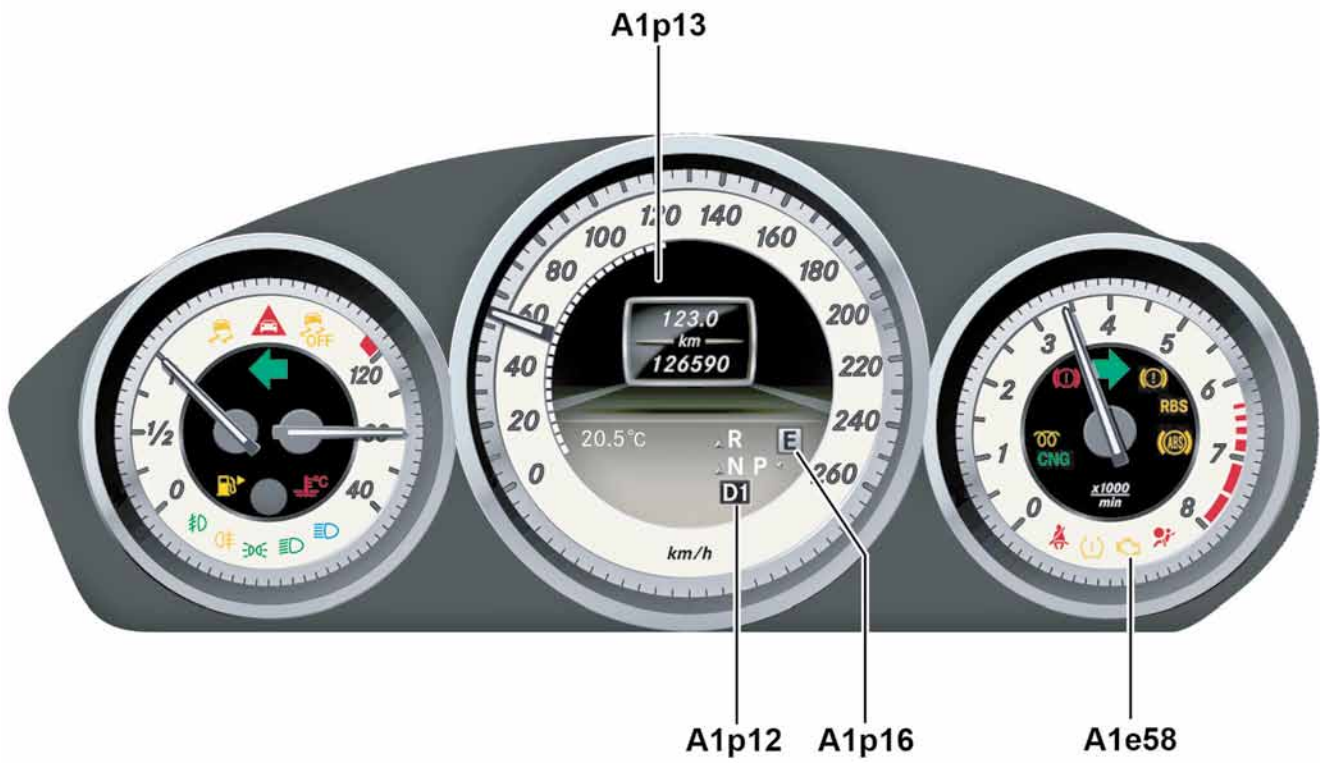

Instrument cluster displays

P54.33-2908-00

A1e58 Engine diagnosis indicator lamp  
 A1p12 Gear indicator

A1p13 Multifunction display  
 A1p16 Transmission mode display

## Limp-home mode

### Emergency operation

In order to guarantee a safe driving condition and to avoid damage to the automatic transmission, the fully integrated transmission control unit switches to limp-home mode in the event of critical faults. In the event of solenoid faults, the affected gear is disabled and no longer actuated. The vehicle can then be brought to the nearest Mercedes-Benz service operation.

### Emergency-P

In the event of faults affecting the park pawl lift solenoid, which prevent the notched lever of the parking lock actuator from being released by the park pawl lift solenoid in position "Not P", the notched lever release pin can compensate for this by opening the notched lever hydraulically. The hydraulic pressure required for this is provided by the electric transmission oil pump with the combustion engine off.

When the Emergency-P function is activated, the locking of the piston rod by the notched lever is canceled (by the energized park pawl lift solenoid or hydraulically by the notched lever release pin if the hydraulic pressure is adequate), the lubricating pressure solenoid is in an energized state and the hydraulic cylinder is not pressurized towards the "Not P" position. The pretensioning spring is supported by the piston rod guide of the piston housing and thus moves the piston rod into shift position "P".

#### **i** Note

The park pawl lift solenoid is actuated in pulses to minimize noise in the vehicle. The solenoid is actuated by the fully integrated transmission control unit or electronic ignition lock control unit if the on-board electrical system voltage is interrupted.

**Torque converter**

The impeller is connected to the engine, the turbine wheel is connected to the drive shaft. The stator is connected to the transmission housing via the freewheel and the stator shaft.

The oil in the torque converter is continuously circulated so that heat generated during the operating phase can be drawn away by the transmission cooler.

The impeller delivers oil through the impeller blades as a result of centrifugal force outwards to the turbine wheel and drives it. The turbine wheel blades direct the oil onto the blades of the stator, which in turn pushes the oil to the impeller. A torque increase occurs due to this redirection at the stator which is supported against the transmission housing via the freewheel.

The torque conversion reaches its maximum value at the start-off point with the impeller rotating and the turbine wheel stationary.

The rpm of the turbine wheel adjusts at an increasing rate during the acceleration phase of the impeller i.e. the rpm difference is reduced until the rpm is almost the same at the coupling point of the torque converter lockup clutch. Once the coupling point is reached, the stator turns freely at the same time.

## Torque converter

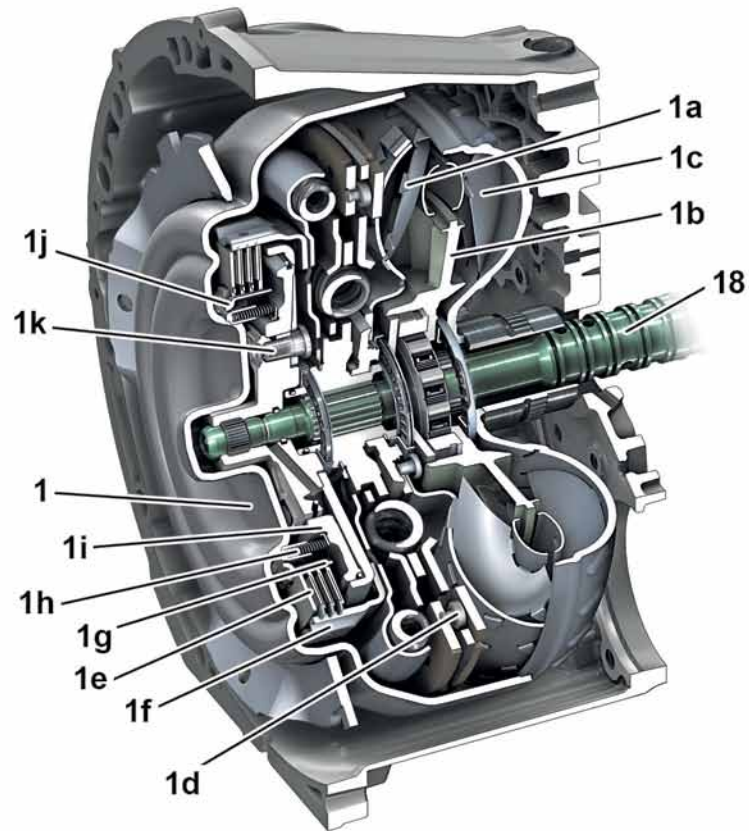

Sectional view of torque converter with centrifugal pendulum

P27.20-2125-00

1	Torque converter cover	1g	Pressure chamber (torque converter lockup clutch)
1a	Turbine wheel	1h	WÜK piston return spring
1b	Stator	1i	Piston
1c	Impeller	1j	Internal plate carrier
1d	Centrifugal pendulum	1k	Rivet
1e	Disk pack	18	Drive shaft (transmission)
1f	External plate carrier		

**Torque converter lockup clutch (WÜK) with centrifugal pendulum**

The torque converter lockup clutch minimizes the power losses of the torque converter and ensures low-slip power flow from the crankshaft to the drive shaft of the automatic transmission depending on the engine load and vehicle speed. This allows the efficiency of the transmission to be improved.

The torque converter lockup clutch is engaged in all gears depending on the output speed, the engine load and further parameters such as temperature and air pressure. In order to minimize the torsional vibrations caused by the combustion engine, additional damping elements and vibration-reducing measures are required:

- Torsional damper
- Centrifugal pendulum

The torsional damper reduces the torsional vibrations caused by the combustion engine as result of combustion jolts. The

pendulum masses of the centrifugal pendulum are mounted flexibly on rollers and produce a counter-moment due to their inertia, which minimizes the torsional vibrations from the engine over the entire rpm range. This measure improves comfort for the driver and saves wear and tear on the mechanical components of the transmission. A low-rpm shift program is possible, which helps to save fuel.

** Note**

Due to the use of a torque converter with centrifugal pendulum and additional damping measures for reducing torsional vibrations, it is not necessary to use a vibration damper on the rear axle differential and propeller shaft.



## Planetary gear set

### Planetary gear set

The following components form part of the planetary gear set:

- Ring gear
- Planet carrier
- Mounted planetary gears
- Sun gear

The ring gear, planet carrier and sun gear elements of a planetary gear set are alternately driven and braked to a standstill via the shift elements of the multidisk clutch and multidisk brake. In the process, the planetary gears can roll on the internal toothing of the ring gear and on the outer toothing of the sun gear. This allows for a variety of gear ratios and the reversal of the rotation direction without the need for moving gear wheels or gearshift sleeves.

The torque conversion and rpm conversion takes place corresponding to the lever ratios or the ratio of the number of teeth of the driven to the driving gear wheels and is designated as the gear ratio "i". With several planetary gear sets connected behind each other, the overall ratio is given by the multiplication of part ratios. If two components of a single planetary gear set are rigidly connected to each other, then this is locked and rotates as a closed unit.

### Advantages of a planetary gear set:

- Shifting ability under load
- Several ratios can be produced
- Constant meshing of the gears
- Simple direction reversal
- High efficiency
- Coaxial location of input and output
- Compact design

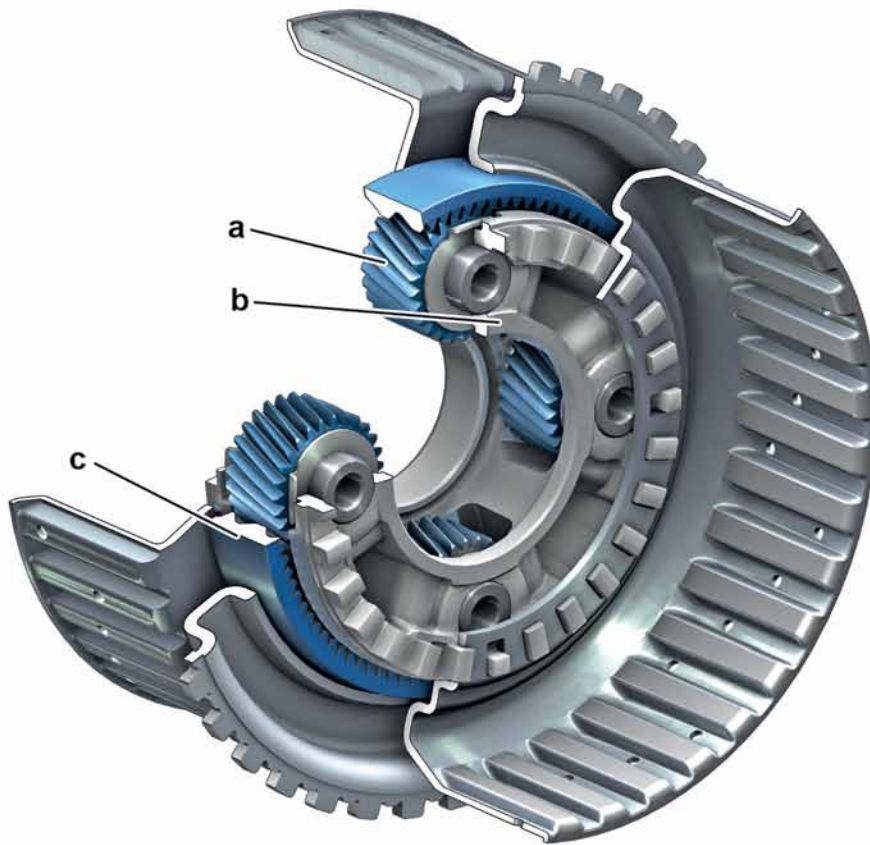
**Planetary gear set**

- a Planetary gear
- b Planet carrier
- c Ring gear

P27.50-2191-00

## Multidisk clutch

### Multidisk clutch

This is used to create a frictional connection for transferring the drive torque between:

- Two elements of a planetary gear set
- One element each from two planetary gear sets

A multidisk clutch consists of a number of internally toothed plates on an internal plate carrier and externally toothed plates on an externally toothed plate carrier. Double-sided disks are used on multidisk clutches K81, K38 and K27. The coated disks of multidisk clutches K38 and K27 are located on the internal plate carrier. Multidisk clutch K81 is in the inverted position with the coated disks in the external plate carrier.

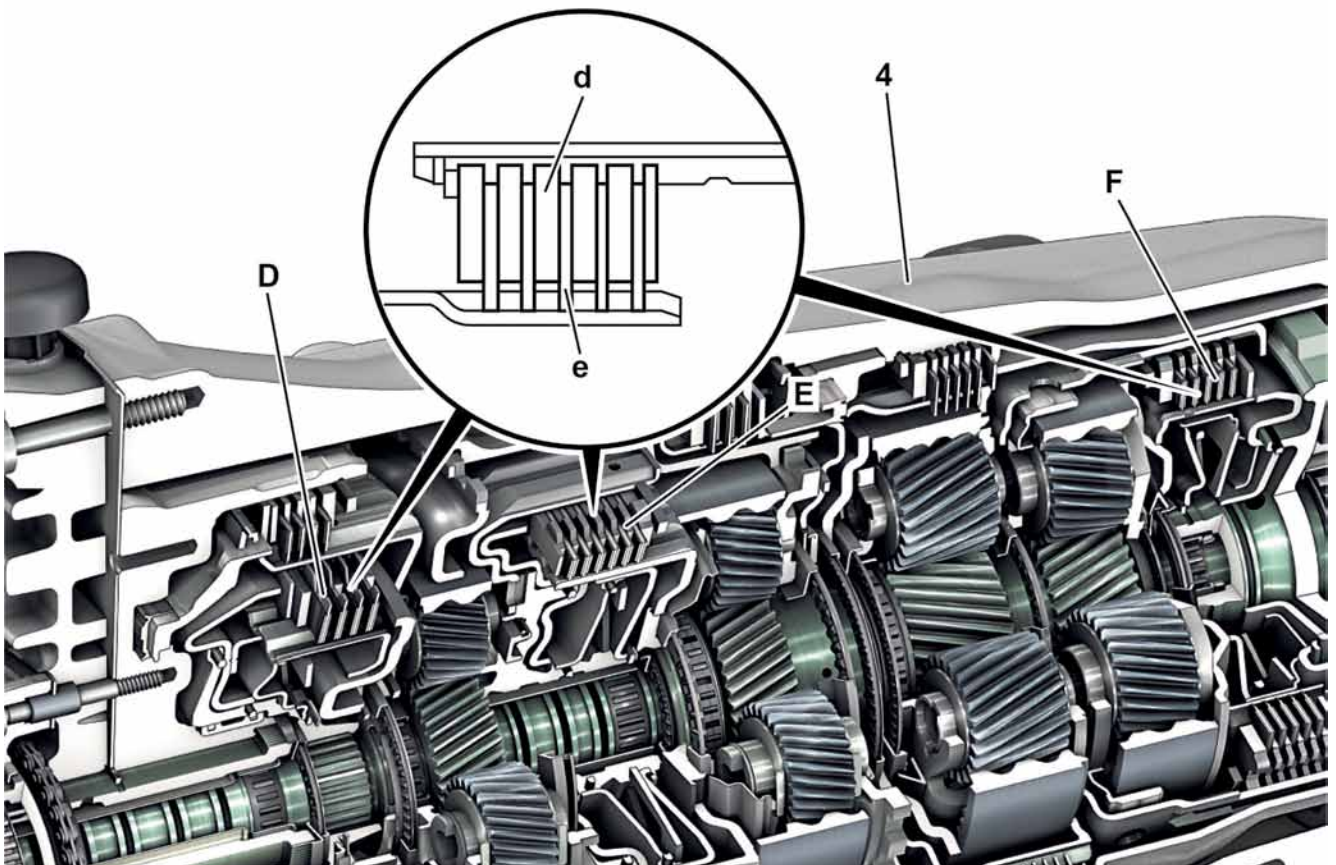

P27.51-2105-00

### Multidisk clutch

4	Transmission housing
D	Multidisk clutch K81
E	Multidisk clutch K38

F	Multidisk clutch K27
d	External plate
e	Internal plate

### Multidisk brake

The multidisk brake supports itself against the transmission housing to transfer the drive torque. The following elements of a planetary gear set can be supported against the transmission housing:

- Ring gear
- Sun gear
- Planet carrier

A multidisk brake consists of several internally toothed plates on an internal plate carrier and externally toothed plates on an external plate carrier. The external plate carrier is permanently connected to the transmission housing. Double-sided disks are used on the multidisk brakes.

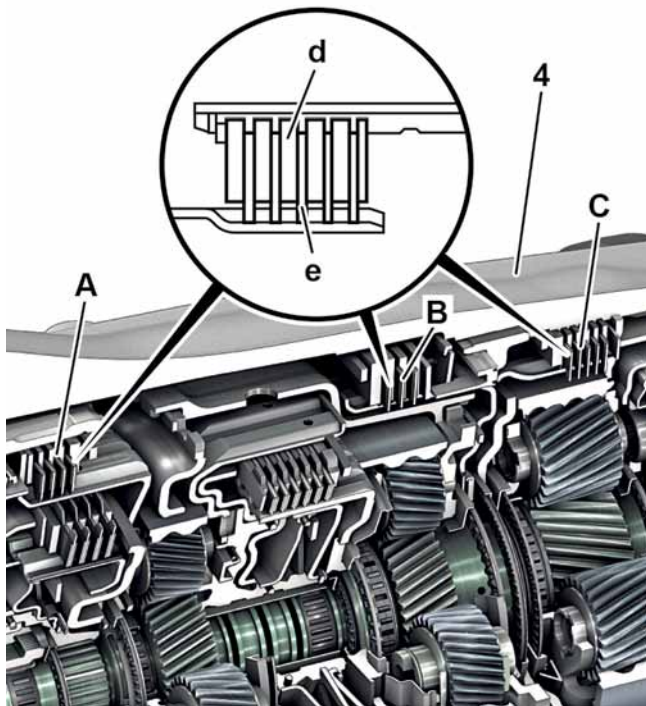

P27.51-2106-00

#### Multidisk brake

4	Transmission housing
A	Multidisk brake B08
B	Multidisk brake B05
C	Multidisk brake B06
d	External plate
e	Internal plate

## Park pawl

### Park pawl

The park pawl gear, the electrohydraulic components and park pawl mechanism are located in the rear part of the transmission housing.

Their task is to secure the vehicle mechanically, in addition to the parking brake, in order to prevent it from rolling away.

In selector lever position "P", the park pawl cone moves between the park detent and pilot bushing. As a result the park detent is pressed against the park pawl gear. If the tooth of the park detent does not engage in a tooth space when the vehicle is stationary, but rather touches a tooth of the park pawl gear, the park pawl cone is pre-tensioned by the spring behind the park pawl cone and positioned ready for operation. When the park pawl gear turns further, the park detent engages in the next tooth gap. To prevent damage due to incorrect operation, the intervals between the tooth gaps are such that the park detent can only engage when the vehicle is stationary or crawling at low speed. If the vehicle moves faster, the park detent is deflected by the oblique surfaces of the teeth and cannot engage. The park detent spring keeps the park detent away from the park pawl gear in gear ranges "R", "N", "D1 to D9".

### Park pawl control

There is no mechanical connection whatsoever between the park pawl components of the transmission and the DIRECT SELECT lever (park-by-wire). The park pawl is engaged and disengaged purely by electrohydraulic means, either through actuation of the DIRECT SELECT lever or depending on various factors such as opening of the driver door, the drivetrain entering an operational status or removal of the ignition key.

### Park pawl position sensor

The park pawl position sensor is used to monitor the position of the park pawl piston (position P and position Not P). The position of the park pawl piston is recorded by a linear Hall sensor. The sensor element for the sensor is a permanent magnet which is clipped onto the piston rod.

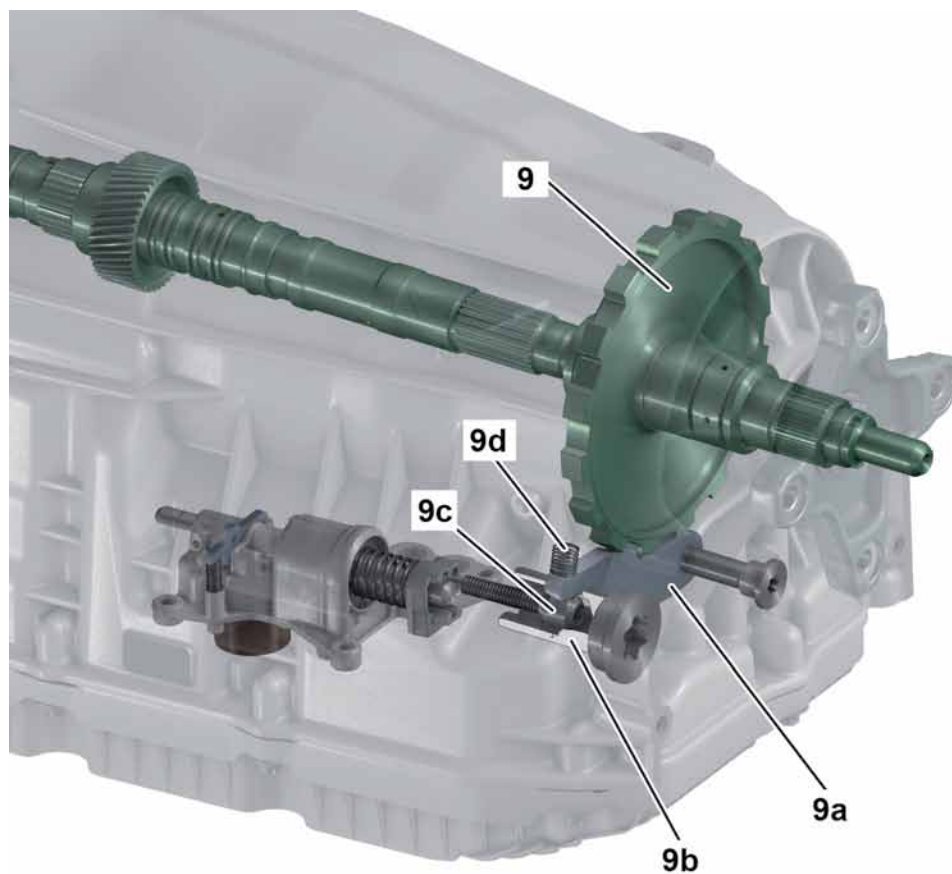

## Automatic transmission from left rear (park pawl engaged)

9	Park pawl gear	9c	Park pawl cone
9a	Park detent	9d	Park detent spring
9b	Pilot bushing		

P27.00-2388-00

## Park pawl control

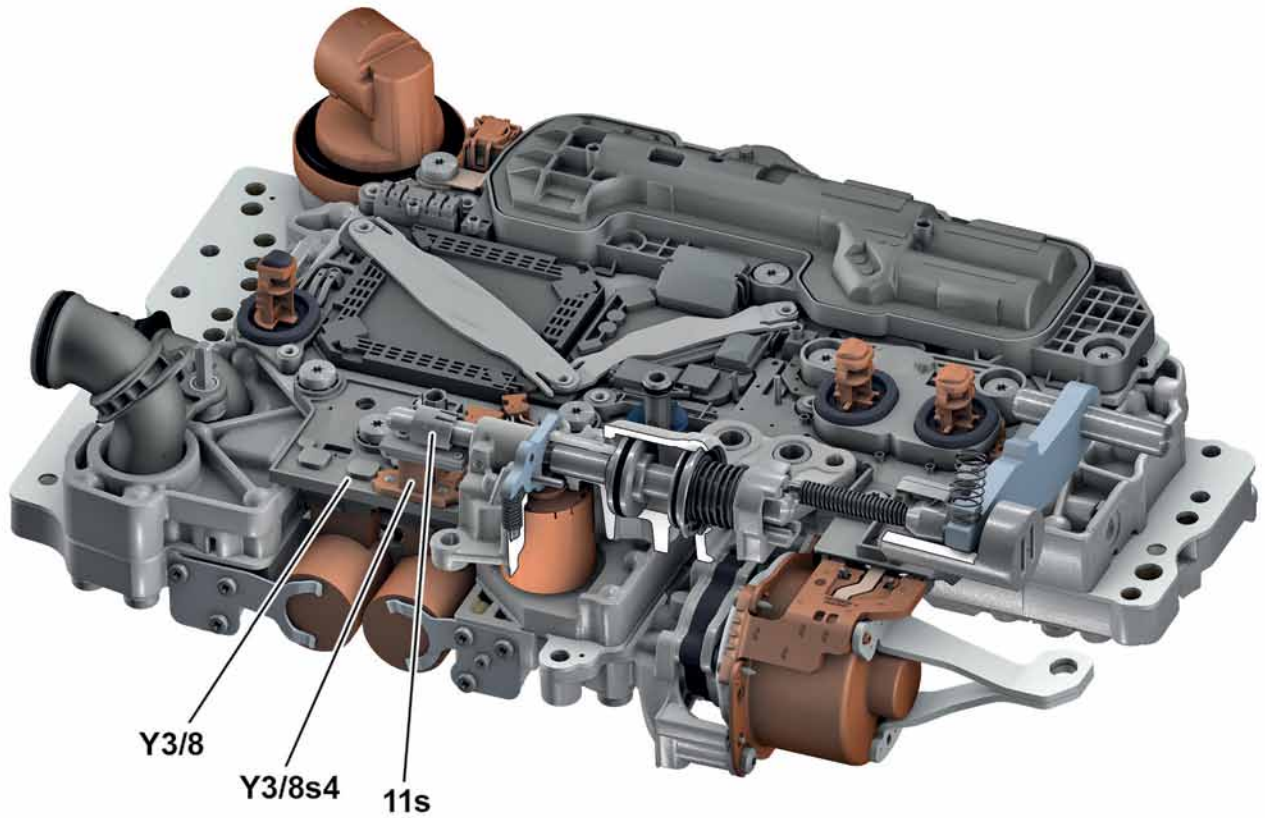

## Components of EHS with park pawl control

11s	Permanent magnet
Y3/8	Fully integrated transmission controller unit
Y3/8s4	Park pawl position sensor

P27.19-2623-00

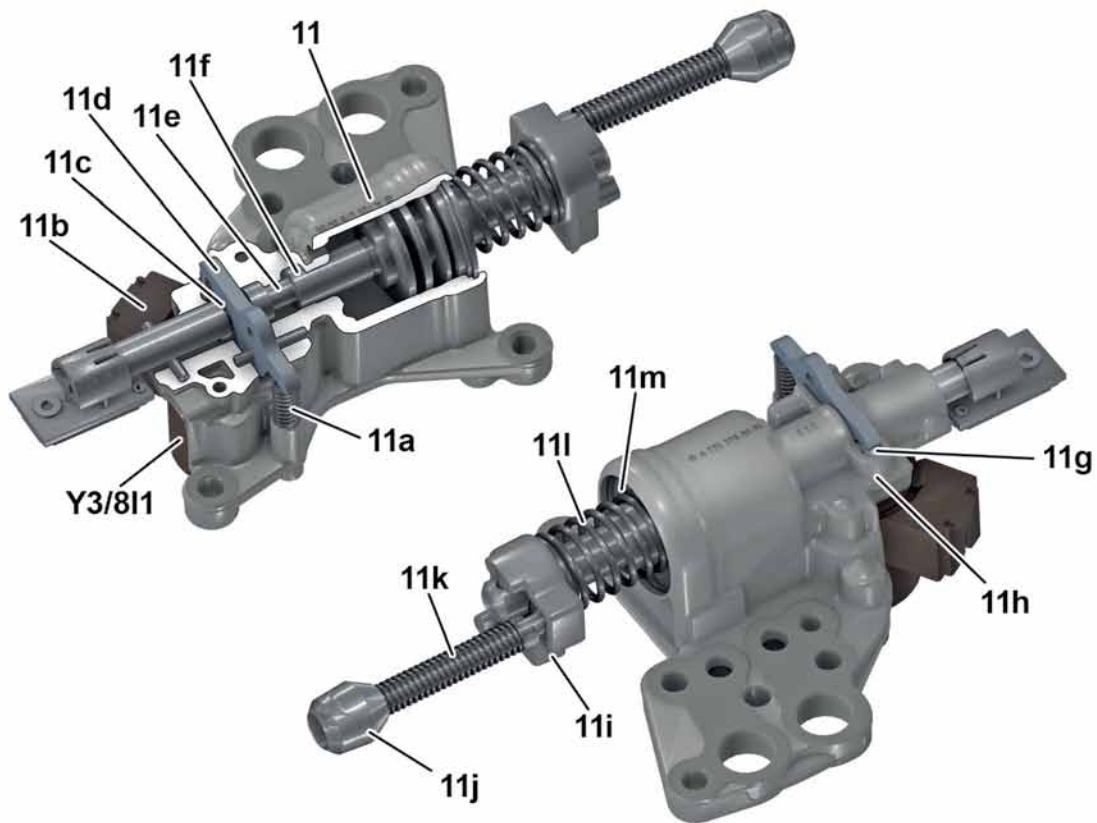

#### Electrohydraulic park pawl actuation

P27.60-3649-00

11	Piston housing	11h	"P" pressure chamber
11a	Catch spring	11i	Spring retainer
11b	Park pawl lift solenoid electrical connector	11j	Park pawl cone
11c	"P" locking contour	11k	Link rod
11d	Notched lever	11l	Pretensioning spring
11e	Locking contour "Not P"	11m	Piston rod guide
11f	Piston rod	Y3/811	Park pawl lift solenoid
11g	Notched lever release pin		



## Park pawl control

### Park pawl shift position "P"

When the driver shifts the DIRECT SELECT lever to gear range "P", the pressure in pressure chamber "Not P" is released.

At the same time, the fully integrated transmission control unit energizes the park pawl lift solenoids. This lifts the notched lever out of locking contour "Not P" against the spring force of the catch spring and thus prevents the "mechanical locking" of the piston rod. Due to the spring force of the pre-tensioning spring, the piston rod, which is coupled to the link rod, is pressed towards the park pawl gear and the park pawl cone is moved between the pilot bushing and park detent.

The rising profile of the park pawl cone raises the park detent and presses it against the park pawl gear. If the tooth of the park detent does not engage in a tooth space when the vehicle is stationary, but rather touches a tooth of the park pawl gear, the park pawl cone is pre-tensioned by the spring of the link rod and positioned ready for operation. When the park pawl gear turns further, the park detent engages in the next tooth gap. When the park pawl is in position "P", the fully integrated transmission control unit terminates the energization of the park pawl lift solenoid.

When deenergized, the park pawl lift solenoid falls back into its initial position and no longer applies any pressure to the notched lever. This is pressed into locking contour "P" by the spring force of the catch spring and thus locks the piston rod.

**Park pawl shift position "Not P"**

If the driver shifts out of gear range "P" into "R", "N" or "D", the park pawl is moved against the spring force of the pretensioning spring towards shift position "Not P" through the application of pressure to pressure chamber "Not P". This takes place after the notched lever is raised against the force of the catch spring through energization of the park pawl lift solenoid, thus opening the mechanical lock. If there is a sufficiently high working pressure, the park pawl is only held in position "Not P" by the hydraulic pressure. There is no contact between the piston rod and notched lever in the axial direction. The piston rod only moves against the catch due to the force of the pretensioning spring if the pressure reduces (pretensioning spring force > hydraulic pressure) or if there is a complete pressure drop. The condition "Not P" is then maintained by the "mechanical lock".

In shift position "Not P", the park pawl cone is positioned in front of the park detent and the park pawl gear can turn freely. The park pawl lift solenoid is actuated in pulses to minimize power loss in the fully integrated transmission control unit. The solenoid is actuated by the fully integrated transmission control unit or electronic ignition lock control unit if the on-board electrical system voltage is interrupted. The time period during which the fully integrated transmission control unit energizes the park pawl lift solenoid is generally measured to ensure that the piston rod reaches its new position before the energization is stopped.

**Actuation of park pawl shift position "P" in the event of defective park pawl lift solenoid**

If the park pawl lift solenoid cannot be actuated or is defective, the mechanical lock of the notched lever is released by the notch lever release pin. The notched lever release pin is actuated hydraulically by the application of pressure to pressure chamber "P".

As a result, the notched lever is raised out of locking contour "Not P" of the piston rod and the park pawl is engaged by the spring force of the pretensioning spring.

**Note**

Emergency engagement of park pawl

When the park pawl lift solenoid is intact, the electric transmission oil pump opens the park pawl (Not P) hydraulically with the combustion engine off. Engagement is carried out mechanically by means of a spring. If the park pawl lift solenoid is defective, the actuator is released by the notch lever release pin but only from position "Not P" towards "P". If the lift solenoid is defective, it is not possible to shift from position "P" to "Not P" i.e. there is no longer an emergency release function.

## Park pawl control

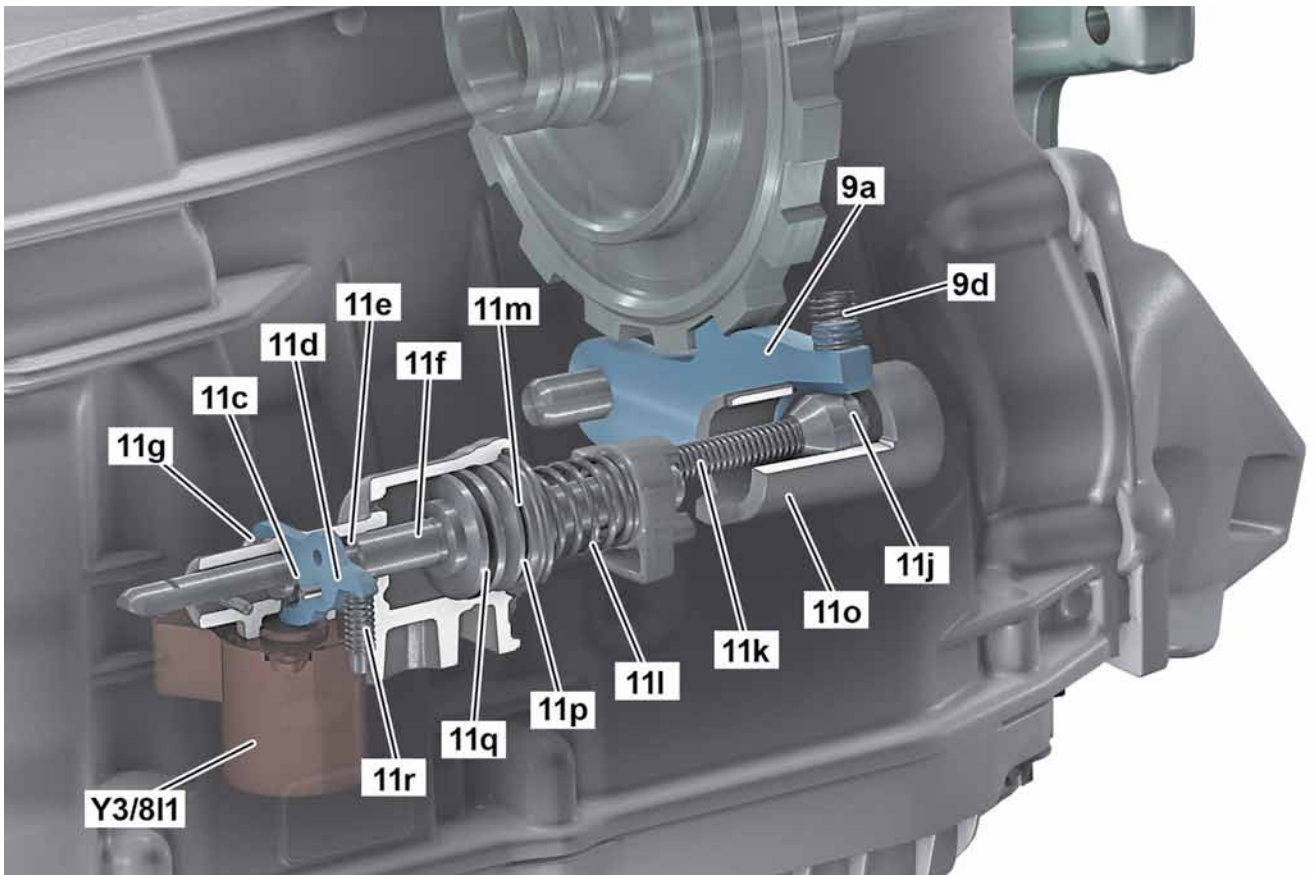

## Electrohydraulic park pawl actuation (park pawl engaged)

P27.60-3651-00

9a	Park detent	11k	Link rod
9d	Spring	11l	Pretensioning spring
11c	"P" locking contour	11m	Piston rod guide
11d	Notched lever (locked)	11o	Pilot bushing
11e	Locking contour "Not P"	11p	Pressure chamber "Not P"
11f	Piston rod	11q	Piston
11g	Notched lever release pin	11r	Catch spring
11j	Park pawl cone	Y3/8I1	Park pawl lift solenoid

**Transmission oil cooling**

Transmission oil cooling lowers the temperature of the transmission oil and thus prevents overheating damage in the transmission.

The transmission oil is suctioned out of the oil pan by a mechanical pump in the transmission and pumped to the transmission oil thermostat via the feed line. At a transmission oil temperature <70 °C, the transmission oil thermostat directs all of the transmission oil back to the transmission via the return line.

At a transmission oil temperature > 90 °C, the transmission oil thermostat opens completely and the transmission oil flows through the transmission cooler, before it flows back through the return line to the transmission.

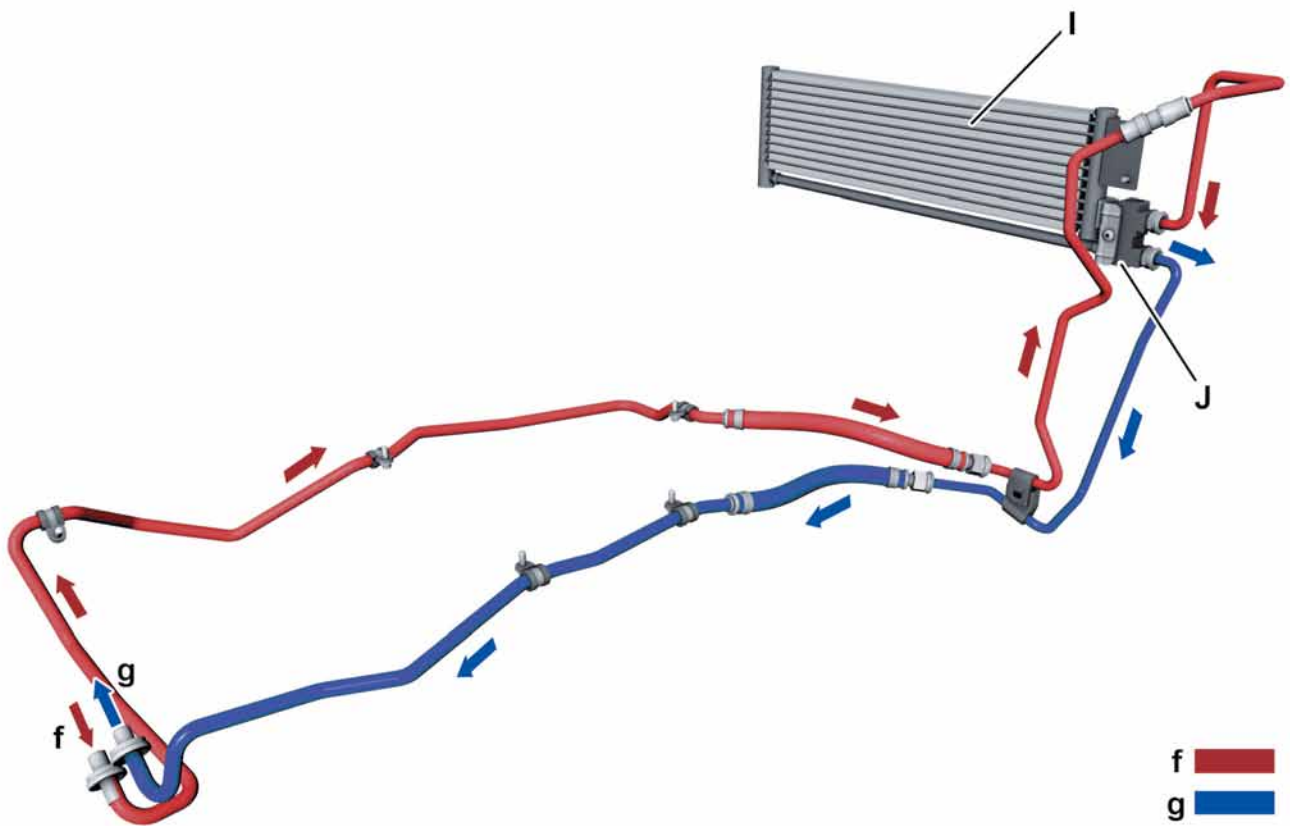

P27.55-2201-00

**Cooling circuit**

- |   |                             |   |                              |
|---|-----------------------------|---|------------------------------|
| I | Transmission cooler         | f | Transmission oil feed line   |
| J | Transmission oil thermostat | g | Transmission oil return line |

## Electric transmission oil pump

### Electric transmission oil pump

The electric transmission oil pump has the following tasks:

- Support the working pressure supply (boosting)
- Support cooling and lubrication
- Provide start/stop capability
- Emergency engagement and emergency release of park pawl

### Support the working pressure supply (boosting)

When there are increased flow rate requirements (e.g. during shift operations), the electric transmission oil pump supports the mechanically driven primary pump according to demand. The additional flow rate provided by the electric transmission oil pump counteracts working pressure dips as a result of undersupply in these situations.

### Support cooling and lubrication

The electric transmission oil pump is actuated according to demand in the event of high cooling and lubrication requirements in order to provide additional flow rate. Due to the possibility of providing additional flow rate according to demand, it was possible to make the primary oil pump significantly smaller and thus reduce CO<sub>2</sub> emissions.

### Provide start/stop capability

When the combustion engine is switched off during the stop phase, the electric transmission oil pump provides the basic pressure level and thus keeps the hydraulic ducts of the electrohydraulic control system and the piston chambers of the shift elements filled with oil. The electric transmission oil pump is operated on a current-controlled basis to supply the exact quantity required to compensate for the leakage of the electrohydraulic actuator. This form of operation allows the power consumption of the electric transmission oil pump to be reduced to the bare minimum during start/stop operation.

### Emergency engagement and emergency release of park pawl

When the park pawl lift solenoid is intact, the electric transmission oil pump activates the park pawl (Not P) hydraulically with the combustion engine off. Engagement is carried out mechanically by means of a spring.

If the park pawl lift solenoid is defective, the park pawl actuator is released hydraulically. In this case, a request is made to the electric transmission oil pump if the combustion engine is off. Emergency release/emergency engagement is only possible towards "P" but not from "P" to "Not P".

The oil feed to the electric transmission oil pump takes place via a separate filter integrated in the oil pan. The transmission oil drawn in is fed by the electric transmission oil pump into the working pressure duct of the electrohydraulic control system.

#### **i** Note

During operation of the electric transmission oil pump alone, a check valve prevents leakage via the stationary oil pump.

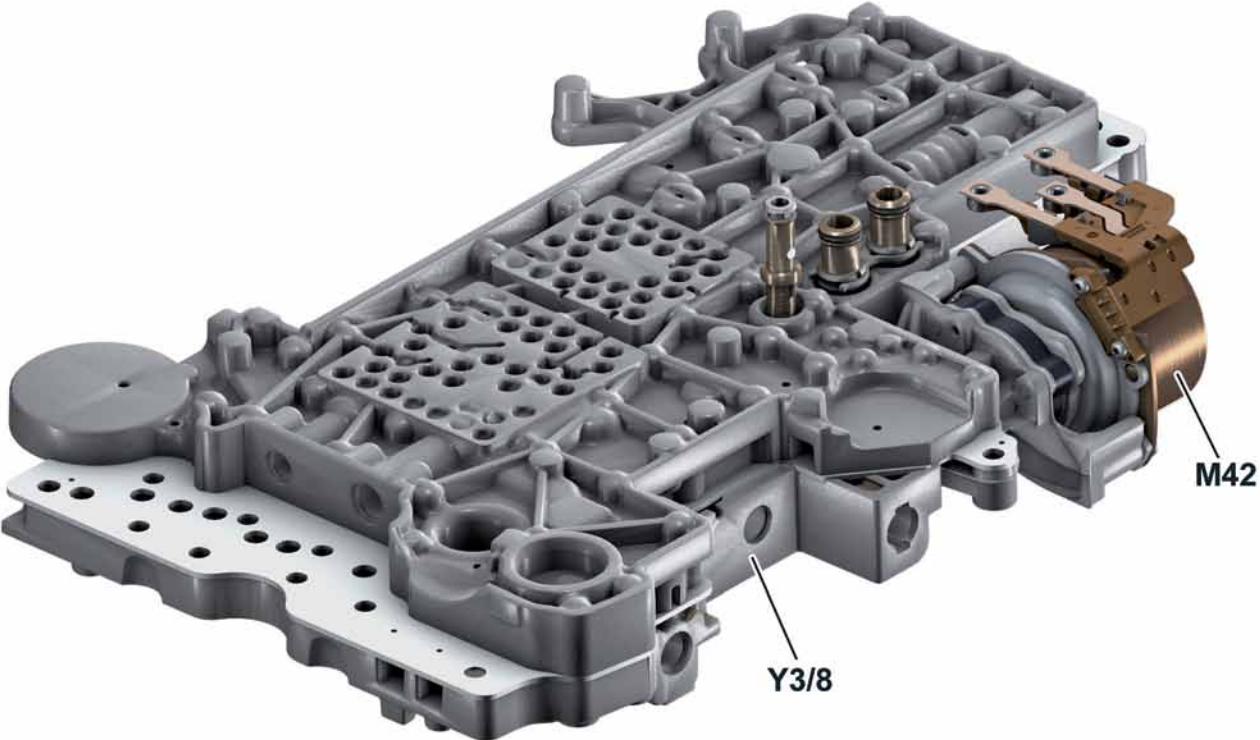

**Cover/shift valve housing**

- M42      Electric transmission oil pump
- Y3/8      Fully integrated transmission controller unit

P27.57-2039-00

## Oil pan and oil filter

### Oil pan with oil filter

The plastic oil pan holds the following components:

- The oil filter for the primary pump
- The oil filter for the electric transmission oil pump
- The two magnets for metallic wear debris

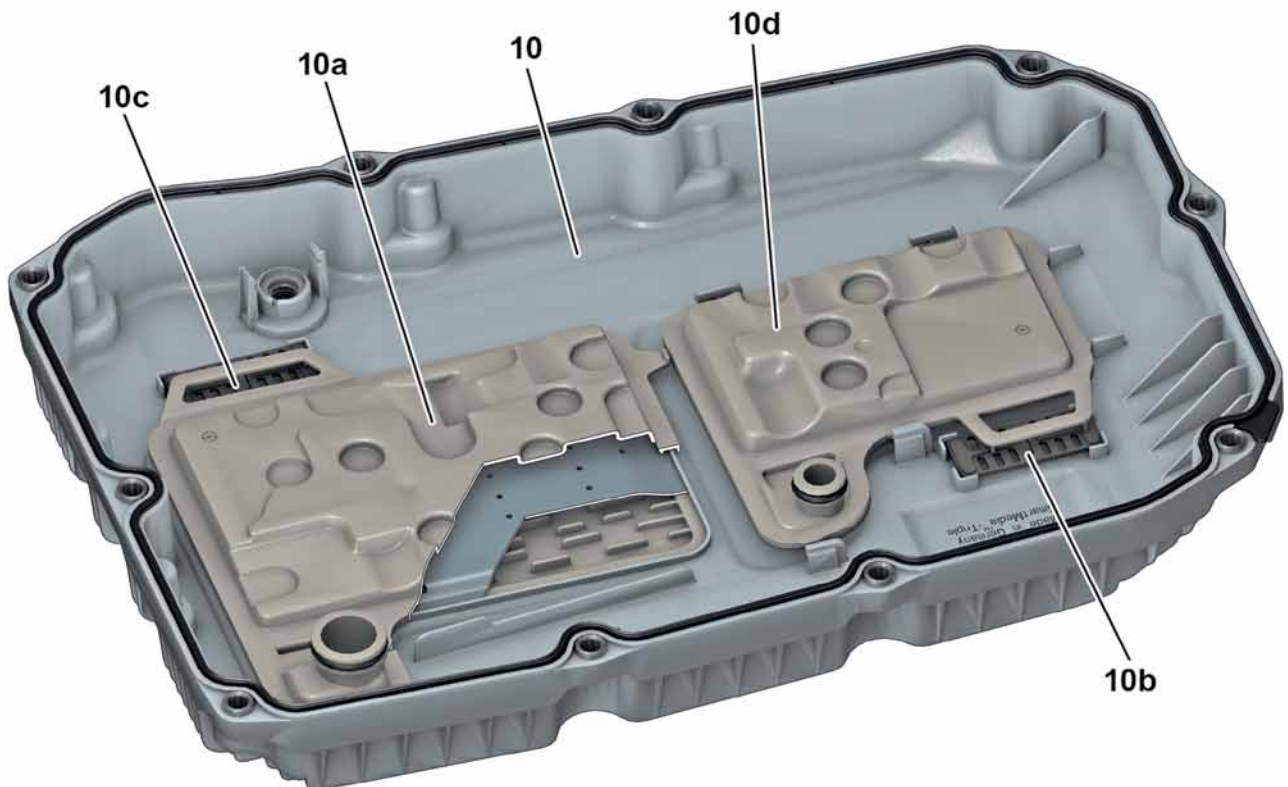

### Oil pan with oil filter

10	Oil pan	10c	Magnet for metallic wear debris
10a	Primary pump oil filter	10d	Electric transmission oil pump oil filter
10b	Magnet for metallic wear debris		

P27.56-0001-00

### Implementation

Certain vehicle data have been transferred from the DVD (installability information and evaluation algorithm) to a central system of Daimler AG. An online connection to a server operated by the manufacturer is required in order to flash and code emissions-relevant control units. Without an online connection, the emissions-relevant data of a control unit may not be modified. This means that, before a control unit is updated via the central server, the data which may be transferred to the control unit must first be determined. The flashware or coding data (useful data) may be provided via the diagnostic tester or server provided that the possibility of manipulated useful data being transferred to a functioning control unit is ruled out.

### Xentry Flash application

Xentry Flash provides support for:

- Coding and programming with online processes
- Initial startup and programming of control units ("flashing")
- Software Calibration Number (SCN) coding and entry of equipment codes for vehicle retrofits and vehicle conversions

The Xentry Flash processes operate much more quickly and conveniently for networked workshops. The programming and coding take place automatically and the user merely has to confirm the operation steps on the relevant screens. Advantage: Increased security and direct customer benefit through reduced waiting times.

Workshops without an online connection cannot use these processes without interruption and also need more support and more time.

More information can be found in the Xentry Flash process description and also on the INFO information system on the Star Diagnosis system and in the Support Tool on the Xentry Kit system.



## Special tools

## Drift

**Use** For mounting radial shaft sealing ring on drive shaft

**MB number** W725 589 00 15 00

**FG** 27

**Set** B

**Category** Special Operations

**Note** -

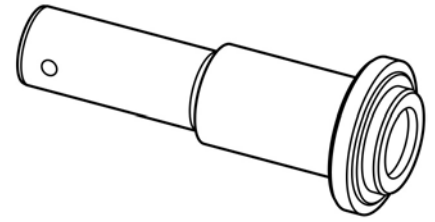

P58.20-2417-00

## Support fixture

**Use** For holding transmission for assembly operations

**MB number** W725 589 00 40 00

**FG** 27

**Set** B

**Category** Special Operations

**Note** -

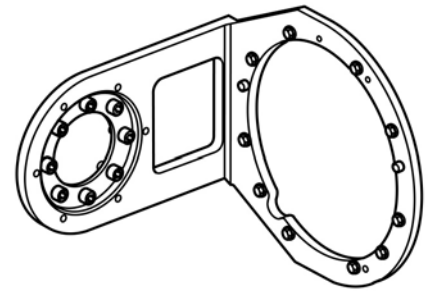

P58.20-2418-00

## Removal and installation tool

**Use** For removing/installing oil pump in torque converter housing

**MB number** W725 589 00 59 00

**FG** 27

**Set** C

**Category** Special Operations

**Note** -

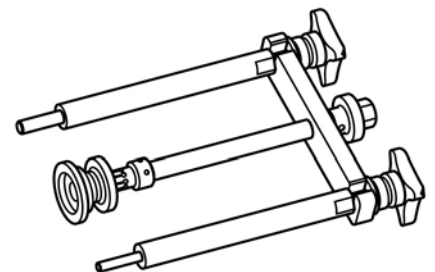

P58.20-2420-00

---

**Adapter**

---

**Use** For filling oil into automatic transmission

---

**MB number** W725 589 00 90 00

---

**FG** 27

---

**Set** B

---

**Category** Basic Operations Compulsory/No Exemptions

---

**Note** -

---

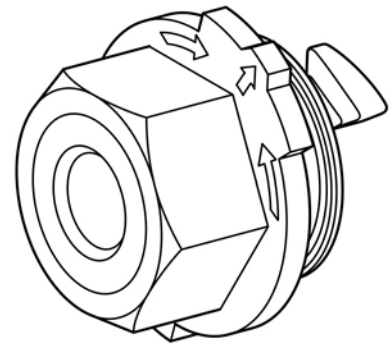

P58.20-2419-00

## Questions about the 9G-TRONIC 725.0 automatic transmission

### How is a sufficient oil supply for lubricating and cooling the mechanical and electrical transmission components provided?

Here, a general distinction is made between oil supply by means of splash oil lubrication, oil supply via the primary pump and oil supply via the electric transmission oil pump:

- The splash oil lubrication serves primarily to lubricate the gear sets.
- The primary pump and electric transmission oil pump provide the hydraulic oil pressure for controlling the actuators and the park pawl.
- The electric transmission oil pump allows the start/stop function to be used and additionally supports the primary pump e.g. at low engine speeds.

### How is the park pawl engaged?

- The park pawl is completely integrated in the transmission housing and is actuated purely by electrohydraulic/electrical means via the fully integrated transmission control unit.

### Is there a mechanical connection between the steering wheel gearshift buttons or DIRECT SELECT lever to the transmission?

- No, gear (range) selection takes place on a solely electric basis without a mechanical connection.

### What happens in the event of defects affecting the park pawl system or solenoids?

- In the event of defects affecting one of the solenoids, the corresponding gear is no longer engaged and it is possible to continue driving to the nearest Mercedes-Benz workshop. In the event of defects affecting the park pawl system, the system is designed to allow the park pawl to be engaged despite a defect. It is not possible to shift out of gear range "P" if the park pawl is defective.

### Are there magnets in the oil pan?

- Two magnets are installed in the oil pan. These have the task of collecting metallic wear debris.

### How is the oil level checked?

- The oil level is checked using the same overflow method as with the 7G-TRONIC 722.9 automatic transmission.

### Which transmission oil is used and can it be mixed with other transmission oils?

- The new golden-yellow GTL automatic transmission fluid may not be mixed with one of the older red (ATF134) or blue fluids (FE-ATF134). Nor may any of the older transmission fluids be used in the 9G-TRONIC 725.0 automatic transmission. Please also refer to the latest Mercedes-Benz Specifications for Operating Fluids (MB BeVo-ONLINE).

### What are the main differences compared to the 7G-TRONIC PLUS 722.9 automatic transmission?

- New patented gear set concept with 4 planetary gear sets and 6 actuators with reduced piston size for quicker, highly dynamic shift operations with maximum comfort and excellent tooth efficiency. Well-balanced gear progression with 9 gears and a gear ratio spread of 9.15. Compact mechanical transmission oil pump with off-axis design and an electric transmission oil pump integrated into the EHS for start/stop operation.

### What are the important points regarding the new direct control system for the solenoids?

- The world's first direct control system for a torque converter automatic transmission allows leakage within the transmission to be significantly reduced. The new direct control system also means that the cleanliness requirements for working on the transmission are even stricter.

### What is the task of the working pressure pressure sensor?

- The working pressure pressure sensor measures the pressure in the feed line to actuator K38. The signal is used for adapting various algorithms e.g. for the no power in "D" adaptation and for reducing the working pressure.

### What is the new service flushing function?

- The new service flushing function can be used to operate (open) all solenoids of the EHS multiple times. This makes it possible to eliminate minor debris without removing the solenoids.

### What adaption types are there on the 9G-TRONIC 725.0 automatic transmission?

The 9G-TRONIC 725.0 automatic transmission features the same standstill adaptation function from the 7G-TRONIC PLUS 722.9 automatic transmission. It is also possible to perform standstill adaptation of the coupling point as on the current wet clutch of the 7G-TRONIC 722.9 Sport automatic transmission (AMG vehicles). This makes it possible to adapt the entire automatic transmission at a standstill for the first time.

This eliminates the need for a time-consuming adaptation test drive. Certain boundary conditions must be met to carry out standstill adaptation. Star Diagnosis guides you through the entire adaptation process.

## Abbreviations

**ATF**

Automatic Transmission Fluid

**CAN**

Controller Area Network

**CO<sub>2</sub>**

Carbon dioxide

**D**

Gear range D

**E**

Economy transmission mode

**EHS**

Electrohydraulic actuator

**EMV**

Electromagnetic compatibility (EMC)

**GTL**

Gas-to-Liquids

**LIN**

Local Interconnect Network

**M**

Manual transmission mode

**N**

Neutral gear range

**P**

Park gear range

**R**

Reverse gear range

**S**

Sport transmission mode

**VGS**

Fully integrated transmission control

**WIS**

Workshop Information System

**WÜK**

Torque converter lockup clutch

- C**  
Centrifugal pendulum 7, 30, 31  
Control pressure 12
- D**  
DIRECT SELECT lever 9, 23, 26, 36, 40, 52
- E**  
Emergency-P 28
- G**  
Gear indicator 9, 26, 27
- L**  
Limp-home mode 28  
Lubricating pressure 9, 12, 16, 17
- M**  
Multidisk brake 7, 9, 10, 12, 16, 21, 22, 35  
Multidisk clutch 7, 10, 12, 21, 22, 34
- O**  
Oil pump 7, 12, 25
- P**  
Park pawl 7, 9, 12, 16, 36, 37, 38, 39, 40, 41, 42  
Planetary gear set 7, 21, 22, 32, 33
- R**  
Rpm sensor 19, 20
- S**  
Shift operation 23  
Shift pressure 12, 14  
Shift valve housing 15, 17
- T**  
Torque converter 5, 7, 9, 12, 16, 22, 29, 30, 31, 54  
Torque converter lockup clutch 7, 9, 12, 16, 22, 31, 54  
Transmission cooler 12, 43  
Transmission mode display 9
- W**  
Working pressure 9, 12

## Space for notes

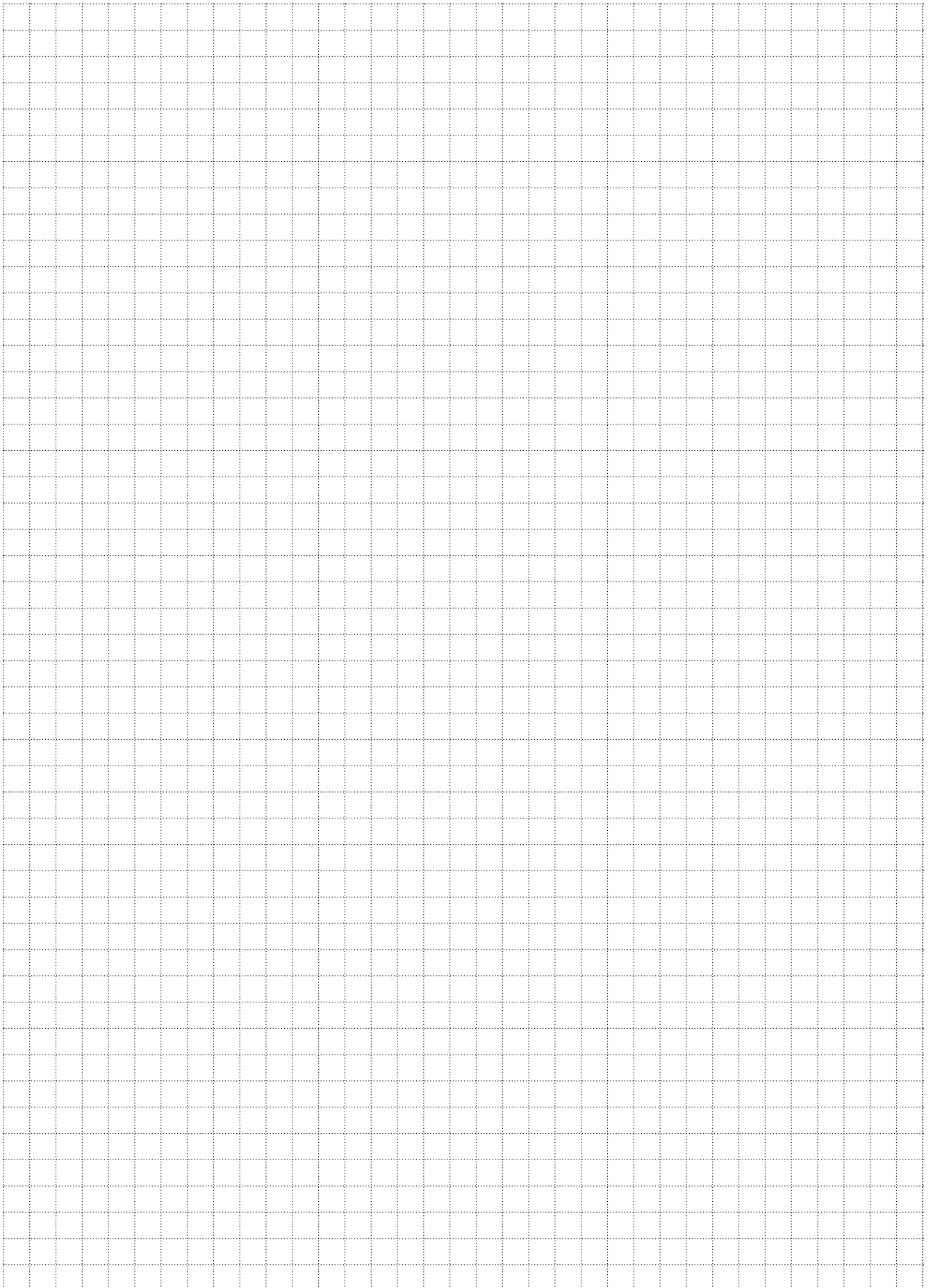

## Space for notes

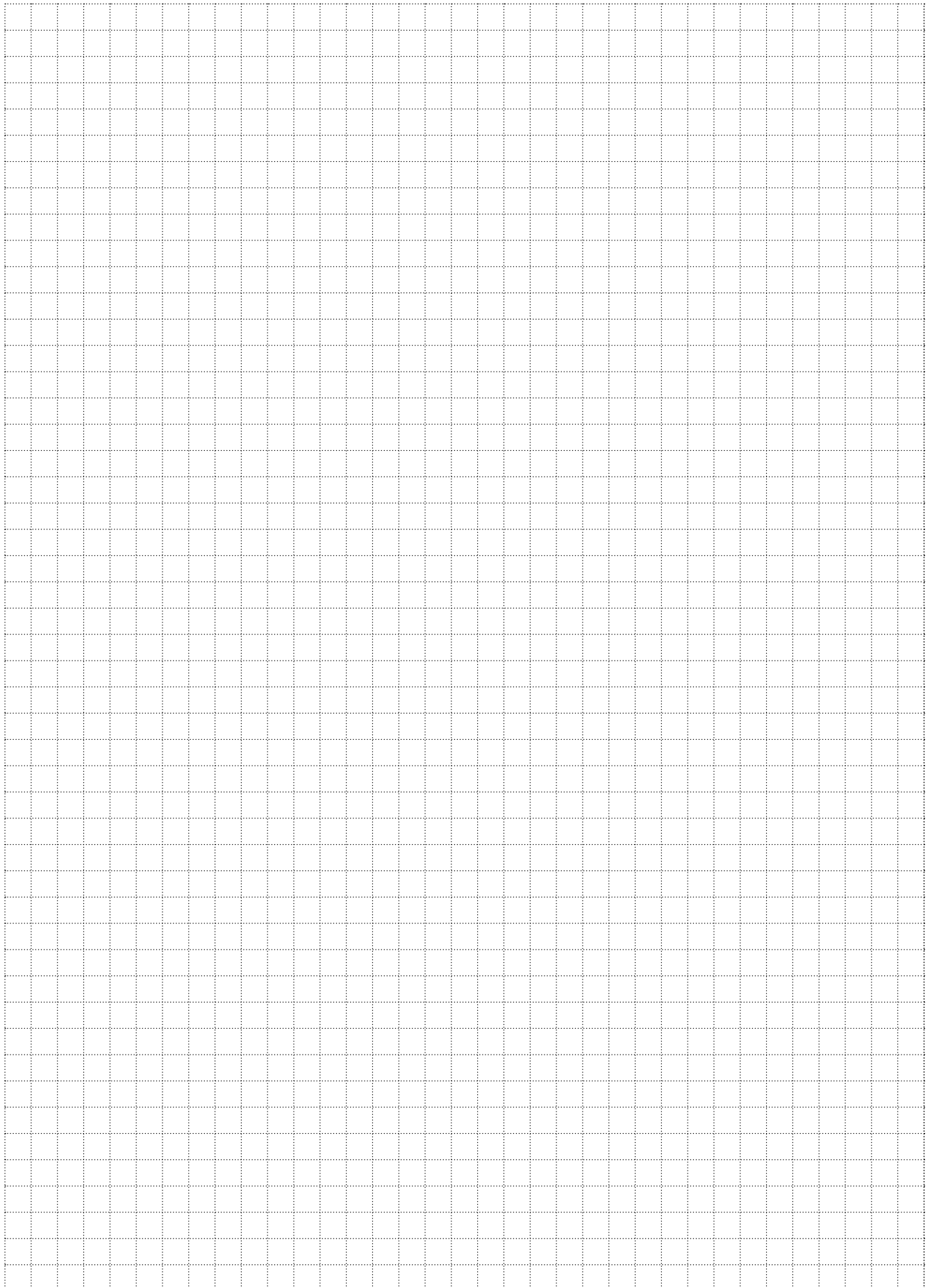



## Space for notes

