

- Parts list -

Vehicle	C905613 (62J)	616 CDI	
Assortment class	Van	Group	27 722.6 MERCEDES-BENZ AUT.TRANSMISSION
Sub-group	100 ELECTRONIC-HYDRAULIC CONTROL UNIT		

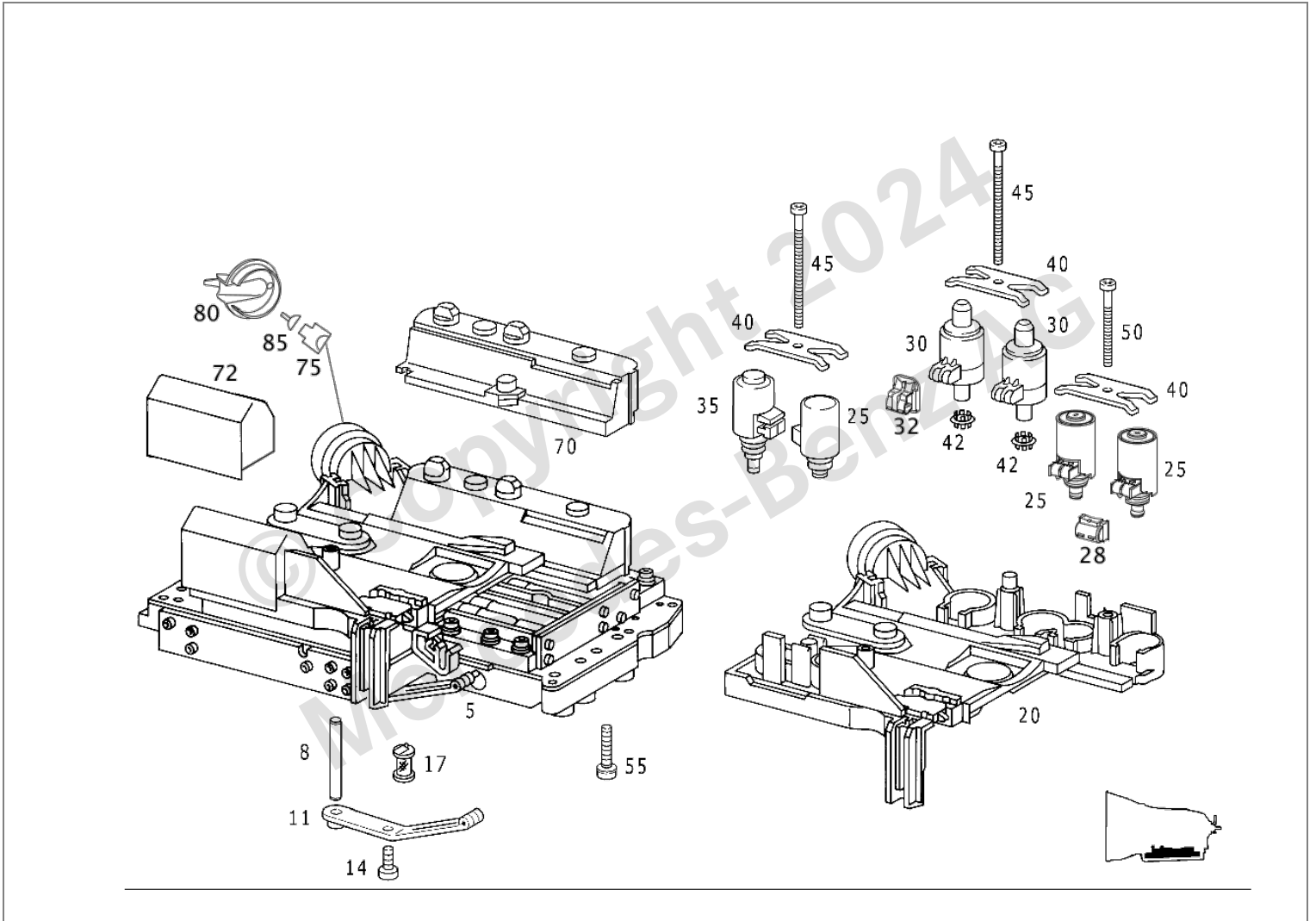











Image ID: drawing_B2710000057

Item	Part number	Designation/additional information	Qty
5	A 140 270 06 06 ↔	* CONTROL ELECTRONIC-HYDRAULIC CONTROL UNIT 📅 [681]	1
8	A 140 277 00 75 🔧	** PIN Replaced by: A 140 277 01 75	1

8	A 140 277 01 75	** CYLINDER PIN Logistical replacement for A 140 277 00 75 Replaces: A 140 277 00 75	1
8	A 140 277 01 75 	** CYLINDER PIN  [402] NO LONGER AVAILABLE	1
11	A 140 270 01 78	** SPRING DETENT-PLATE LEAF SPRING  [402] NO LONGER AVAILABLE	1
14	A 140 277 08 71	** SCREW Replaced by: A 170 990 01 20	1
14	A 170 990 01 20	** SCREW Logistical replacement for A 140 277 08 71 Replaces: A 140 277 08 71	1
17	A 140 270 02 98	** FILTER	2
20	A 140 270 05 61 	** TRANSMISSION ELECTRIC KIT Replaced by: A 140 270 07 61 Replaced by: A 140 270 08 61 Replaced by: A 140 270 11 61	-
20	A 140 270 07 61 	** TRANSMISSION ELECTRIC KIT Replaced by: A 140 270 08 61 Replaced by: A 140 270 11 61 Replaces: A 140 270 05 61	1
20	A 140 270 08 61 	** TRANSMISSION ELECTRIC KIT Replaced by: A 140 270 11 61 Replaces: A 140 270 05 61 Replaces: A 140 270 07 61	1
20	A 140 270 11 61 	** TRANSMISSION ELECTRIC KIT Replaces: A 140 270 05 61 Replaces: A 140 270 07 61 Replaces: A 140 270 08 61	1
25	A 140 277 05 35	** SOLENOID VALVE Replaced by: A 240 270 01 89 Replaced by: A 240 270 02 89 Replaced by: A 240 270 16 00	-
25	A 240 270 01 89	** SOLENOID VALVE SOLENOID VALVE Replaced by: A 240 270 02 89 Replaced by: A 240 270 16 00	3

Replaces: A 140 277 05 35

25	A 240 270 02 89	** SOLENOID VALVE SOLENOID VALVE Replaced by: A 240 270 16 00 Replaces: A 140 277 05 35 Replaces: A 240 270 01 89	3
25	A 240 270 16 00	** PRESSURE REGULATING VALVE Logistical replacement for A 240 270 02 89 Replaces: A 140 277 05 35 Replaces: A 240 270 01 89 Replaces: A 240 270 02 89	3
28	A 240 271 01 82	** CAP  [417] IS NO LONGER DELIVERED, ORDER DELIVERY CONTENTS	3
30	A 140 277 03 98	** CONTROL SOLENOID Replaced by: A 203 270 00 89	-
30	A 203 270 00 89	** VALVE PRESSURE CONTROL VALVE Replaces: A 140 277 03 98	2
32	A 240 271 00 82	** CAP  [417] IS NO LONGER DELIVERED, ORDER DELIVERY CONTENTS	2
35	A 140 277 04 35	** VALVE SOLENOID VALVE Replaced by: A 240 270 17 00	1
35	A 240 270 17 00	** PRESSURE REGULATING VALVE Logistical replacement for A 140 277 04 35 Replaces: A 140 277 04 35	1
40	A 140 276 02 03	** SPRING STEEL SHEET	3
42	A 140 270 04 98	** FILTER	2
45	A 140 277 10 71	** SCREW	2
50	A 140 277 11 71	** SCREW	1
55	A 140 277 06 71	** CAP SCREW WITH FLANGE	10
70	A 140 271 07 82	** CAP	1
72	A 140 271 08 82	** CAP  [402] NO LONGER AVAILABLE	1

75	A 001 540 99 81	SOCKET HOUSING 12-PIN LKS1.5	1
80	A 001 545 26 83	CAP	1
85	A 000 540 42 05	ELECTRIC LINE REPAIR SOLUTION CONTACTING 1.0 MM2; 1.0 MM2 LKS 1.5 📄 [774] CONNECTORS MUST ALSO BE ORDERED ACCORDING TO THE TOTAL LINE CROSS-SECTION TO BE CONNECTED. FOR REPAIR INSTRUCTIONS, SEE WIS SOLD.CONN.SLVS: A 001 546 99 41 GREEN 0.7 - 2.4 MM2 A 002 546 00 41 RED 2.0 - 4.0 MM2 A 002 546 01 41 BLUE 3.5 - 8.0 MM2 A 002 546 11 41 YELLOW 7.5 - 12.0 MM2 BUTT CONNECTOR: A 002 546 13 41 0.5 MM2 A 002 546 14 41 0.8 MM2 A 002 546 15 41 1.3 MM2 A 002 546 16 41 2.0 MM2	NB