

Operation no. of operation texts and work units
or standard texts and flat rates:

B. Engine 119

Preliminary work:

Viscous fan coupling removed (20-3120).

Poly V-belt slackened (13-3420).

Engine compartment panels removed (61-0105).

Cross member below radiator removed.

Fan cowl removed.

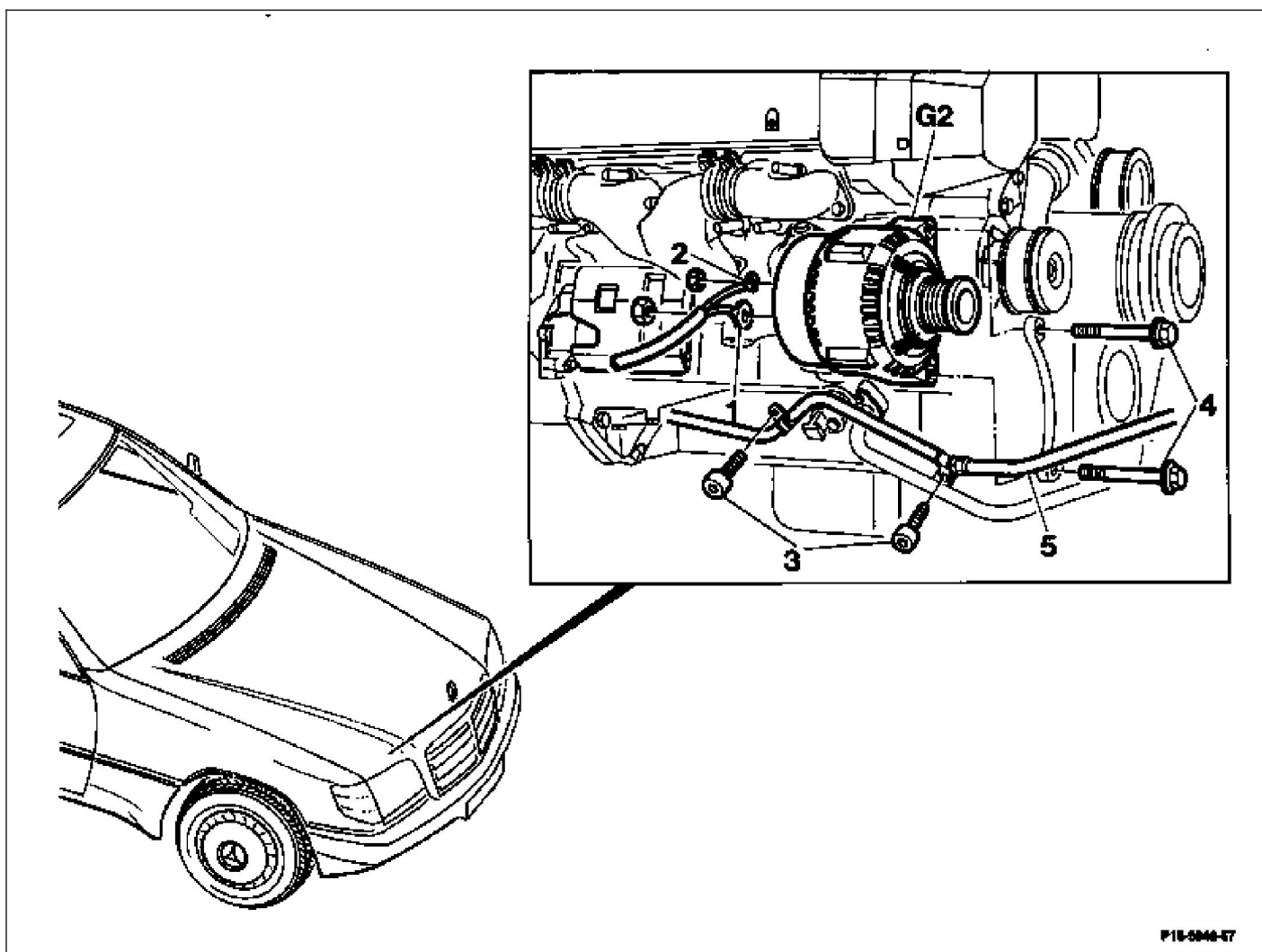

P15-5046-57

P15-5046-57

| | |
|--|----------------------|
| Ground cable at battery..... | disconnect, connect. |
| Electric wiring (1 and 2) at generator (G2)..... | disconnect, connect. |
| Screws (3)..... | unscrew, screw in. |
| Bolts (4)..... | unscrew |

Generator (G2)..... remove upwards, press line (5) slightly to side if necessary, insert from above.