

Specifications

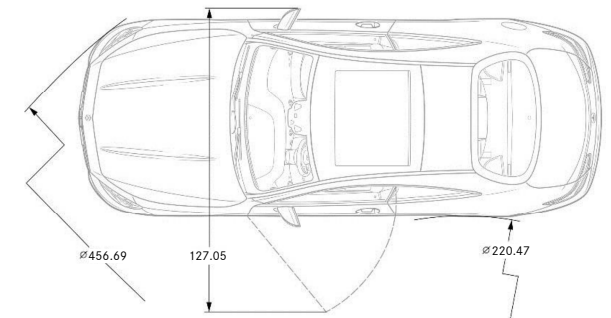

	<i>S 560 4MATIC</i>
Engine Configuration	4.0L V8 biturbo engine
Power (hp)	463
Torque (lb-ft)	516
Displacement (cc)	3.982
Acceleration 0-60 mph (sec)	4.5
Fuel Economy (Cty/Hwy/Comb)	tba
Top Speed (mph)	130
Fuel Requirement (Octane)	tba
Compression	10.5 : 1
Transmission	9G-TRONIC 9-Speed Automatic Transmission
Transmission Speeds	9
Drive Configuration	All-wheel Drive
Fuel Tank Size (gallons)	tba
Trunk Size (cubic feet)	tba
Curb Weight (lbs)	tba
Maximum Load (lbs)	tba
Vehicle Length (in.)	198.11
Vehicle Width w/ exterior mirrors (in.)	82.99
Vehicle Height (in.)	55.55
Wheelbase (in.)	115.94
Track Width Front/Rear (in.)	63.98/64.92
Towing Capacity (lbs)	tba

Specifications – S 560 4MATIC

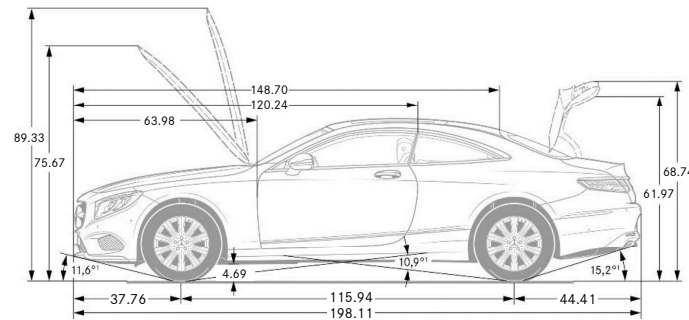
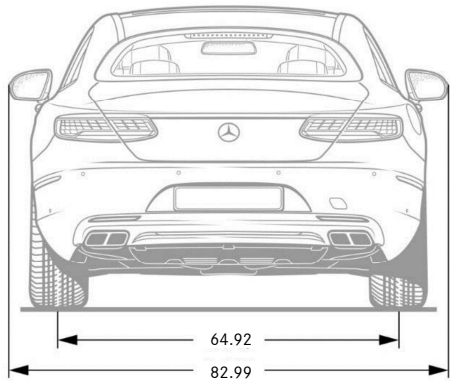
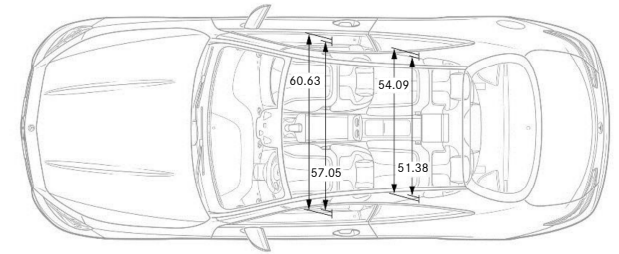
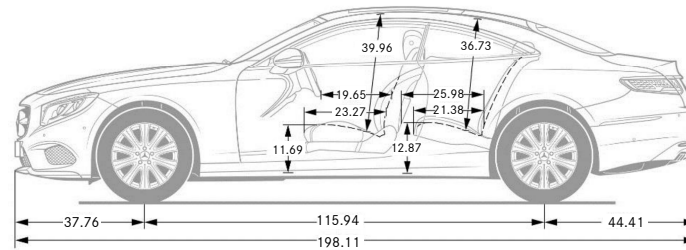
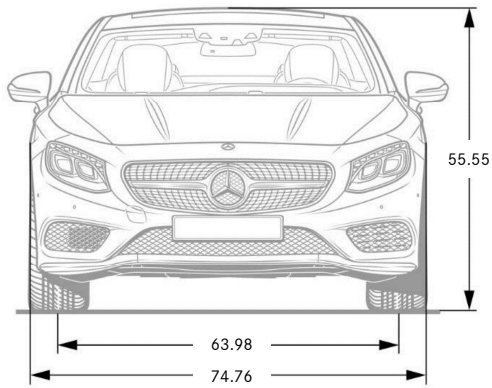

Mercedes-AMG S-Class Coupe



C217

Model Year 2019

Preliminary – Subject to Change

AMG
DRIVING PERFORMANCE

S 63 & S 65



Models



What's new



Standard Equipment



Exterior Paint Colors



Wheels



Interior Upholstery



Interior Trims



Option Packages



Stand-Alone Options



Options in Detail



Specifications



S 63 (217.388)

- MSRP \$169,450
- Handcrafted Mercedes-AMG 4.0L V8 biturbo Engine
- Horsepower 603 hp
- Torque 664 lb-ft
- 3.4 sec (0-60 mph)
- Launch date: Summer 2018



S 65 (217.379)

- MSRP \$241,250
- Handcrafted Mercedes-AMG 6.0L V12 biturbo Engine
- Horsepower 621 hp
- Torque 738 lb-ft
- 4.0 sec (0-60 mph)
- Launch date: Summer 2018

New Optional Equipment

- Introduction of L6L Wood/Leather AMG Performance Steering Wheel
- Introduction of L6H DINAMICA/Carbon Fiber AMG Performance Steering Wheel

Mercedes-AMG S 63 - Exterior Design

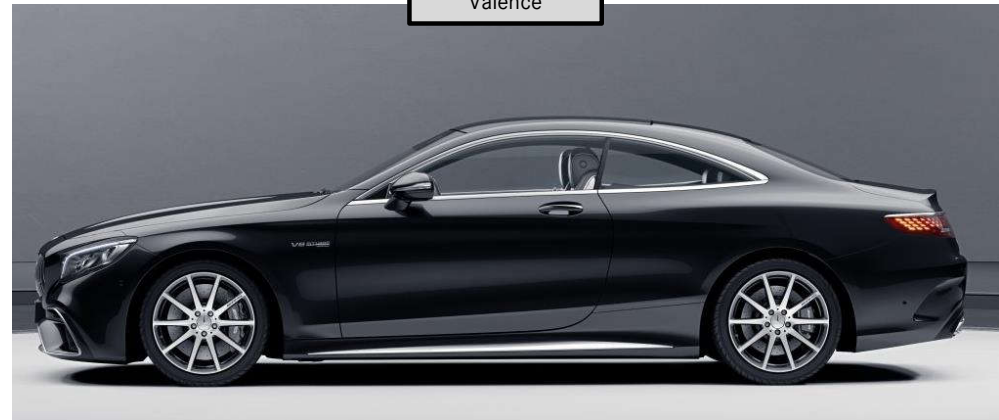

Mercedes-AMG S 65 - Exterior Design

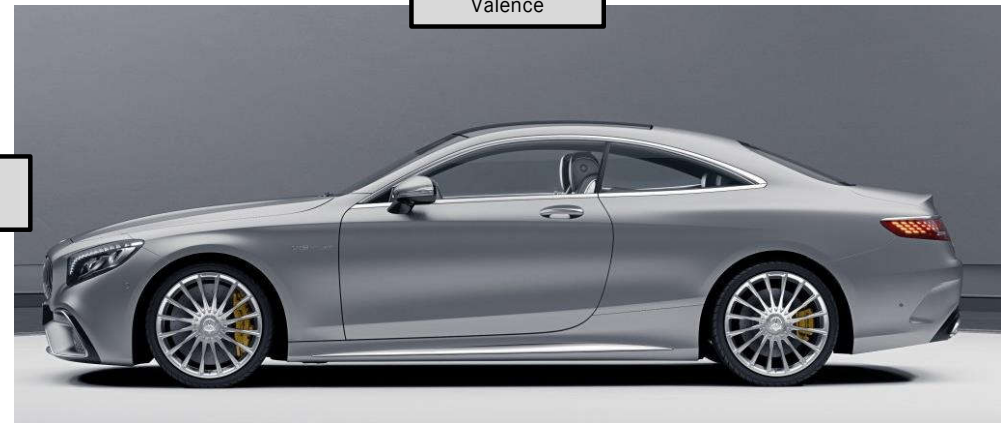

Mercedes-AMG S-class Coupe - Exterior Design



Handcrafted AMG 4.0L V8 biturbo engine (M177 E40DEH LA AMG)



Handcrafted AMG 4.0L V8 Biturbo engine (M177 E40DEH LA AMG)

Standard on S63

- **Aluminum crankcase** featuring a racing inspired closed-deck design
 - The area around the cylinders' coolant enclosure is closed off at the top and is only perforated by cooling channels
 - This makes the engine block more rigid and able to withstand greater loads
- **Forged, lightweight aluminum pistons** – high performance and low weight
- **Two Twin-scroll turbochargers** with separate exhaust channels
 - Positioned between the cylinder heads for faster response
 - Inspired by Formula 1
 - Keeps engine compact, improves turbo response and lowers emissions
 - Separate exhaust channels prevent turbos from having a negative impact on each other during load/directional changes, and enables faster spooling/buildup of turbo pressure
- **Variably Adjustable Inlet and Outlet Valves**
 - Filled with sodium
 - Light weight

AMG Performance 4MATIC+



AMG Performance 4MATIC+

Standard on S63 only

The performance-oriented all-wheel drive with fully variable torque distribution combines optimal traction, hallmark AMG driving dynamics, and the ultimate in driving enjoyment. It enhances driving safety and adhesion on wet or wintry road surfaces while at the same time allowing an emotional drifting experience. This is made possible by the fully variable torque distribution, offering the driver the benefits of all-wheel drive and rear-wheel drive in equal proportions.

An electronically controlled clutch provides for variable connection of the permanently-driven rear axle with the front axle. The ideal torque distribution is calculated continuously, according to the given driving situation and the driver's wishes. This enables a seamless transition from traction-oriented all-wheel drive to 100% rear-wheel drive. In addition to traction and transverse dynamics, the all-wheel drive also improves the longitudinal dynamics of the vehicle for even more dynamic acceleration.

- Combines the advantages of an all-wheel drive with those of a rear-wheel drive: optimum traction, hallmark AMG vehicle dynamics, and maximum driving pleasure
- Drift capability, as fully variable torque distribution means that 100% rear-wheel drive is possible
- Improved handling safety and road holding on wet or wintry road surfaces
- Improved longitudinal dynamics for even more aggressive acceleration
- The compact, lightweight design avoids any loss of space in the interior

AMG SPEEDSHIFT MCT 9-Speed Transmission



AMG SPEEDSHIFT MCT 9-Speed Transmission

Standard on S63 only

MCT stands for Multi-Clutch Transmission, whereby an innovative wet start-off clutch running in an oil bath replaces the conventional torque converter. Thanks to its low rotational inertia, the transmission responds instantaneously without the losses typical of a torque converter. This helps to reduce fuel consumption. A further merit of the MCT transmission is its low weight thanks to its magnesium housing.

Added driving pleasure, added safety – the double-clutching function

Ultra-fast, responsive, multiple downshifts are another forte of the AMG SPEEDSHIFT® MCT 9-speed transmission. The driver can change via kick down directly from 9th into 6th or from 5th into 2nd gear, for example. The automatic double-clutching function is active in drive programs "S", "S+", and "M". Each manual or automatic downshift is accompanied by a precisely metered blip on the throttle – with rising intensity from "S" through to "S+" and "M". This not only heightens the emotional appeal: downshifting minimizes the load cycles, which has a particularly positive effect when braking into corners and makes for improved handling safety on wet and slippery surfaces.

For a perfect start – the RACE START function

The RACE START function ensures optimal acceleration from a standing start. It can be activated when the vehicle is stationary in the AMG DYNAMIC SELECT drive programs "S" or "S+." To activate, the driver is required to hold down the brake pedal with their left foot while simultaneously flooring the accelerator pedal (kick down). The driver can then increase or lower the pulling-away engine speed as appropriate (from 2,000-4,000rpm), according to the prevailing road conditions. When the driver releases the brakes while continuing to floor the accelerator pedal, the vehicle accelerates with the best possible traction and fastest launch.

3-stage ESP®



3-stage ESP®

Standard on S63 only

The three-stage Electronic Stability Program (ESP®) at a glance:

Three separate control strategies for safety and driving pleasure, selectable using the ESP® button or through the AMG DYNAMIC SELECT system:

- "ESP® ON": ensures a high level of safety by adapting the system in line with the vehicle's sporty characteristics
- "ESP® SPORT HANDLING MODE": Allows higher drift angles prior to system intervention for a sporty driving style
- "ESP® OFF": System switched off for sporty driving style on dedicated racetracks

Added driving pleasure, combined with safety

This system provides safety and driving pleasure in equal measure. The ESP® button allows the driver to choose between three individual control strategies: "ESP ON", "ESP SPORT HANDLING MODE" and "ESP OFF". The currently activated mode is indicated in the AMG instrument cluster. With "ESP ON", if the vehicle's road holding starts to become unstable, the brakes are applied on one or more wheels and the engine torque is reduced. "ESP® SPORT HANDLING MODE" is activated as soon as the driver gives the ESP® button a single brief press. In this mode, over/understeer control as well as engine torque control allow more dynamic road holding and therefore corresponding drift angles. "ESP® OFF" is activated when the driver gives the ESP® button a long press. In this mode, in the interests of driving dynamics, the engine torque is no longer reduced. "ESP® OFF" should be used only by experienced drivers on dedicated racetracks.

ESP® Curve Dynamic Assist – more safety in bends

When the ESP sensors register a tendency to understeer on bends, this can be reduced by specific braking intervention at the inside wheels. This intervention leads to a slight yawing motion around the vehicle's vertical axis, counteracting the understeer. At the same time drive torque is increased slightly to the outside wheel to compensate and steer through the bend with precision.

AMG Track Pace App for Apple iPhone®



Demonstrative screens in COMAND system

AMG Track Pace App for Apple iPhone® (256)

Standard on All Models

With the "AMG Track Pace" app, a smartphone can be turned into a personal racing engineer. This enables lap/sector times or even videos to be recorded and analyzed. Another attractive feature is the option to exchange data with other AMG drivers e.g. via social networks.

Overview of the AMG Track Pace app:

- Stores vehicle-specific data (e.g. speed, acceleration) as well as lap and sector times
- Video recordings via smartphone/GoPro are also possible
- Driving ability can be analyzed and improved in a targeted manner
- Connection via WLAN
- Exchange data with other AMG drivers via social networks such as Facebook (Share function) or the AMG Private Lounge

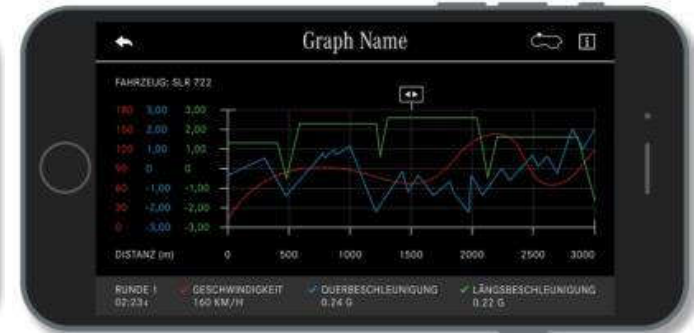

Standard Equipment



Performance & Handling

- 3-stage ESP® with Curve Dynamic Assist
- AMG High-Performance Compound Braking System
- New-generation AMG Performance Steering Wheel with Shift Paddles
- AMG Adaptive Sport Suspension
- AMG DYNAMIC SELECT with 4 modes
- AMG Track Pace App
- AMG-exclusive Sport Instrument Cluster Design
- AMG-specific multilink suspension geometry
- RACE START (S 63 Only)
- AMG Performance 4MATIC+ (S 63 Only)
- AMG Performance Exhaust System (S 63 only)
- AMG Sport Exhaust System (S 65 only)
- 20" Aluminum Alloy Wheels (S 63 only)
- 20" Forged Aluminum wheels (S 65 only)
- MAGIC BODY CONTROL with Road Surface Scan and Curve Tilting Function (S 65 Only)
- Carbon Fiber Engine Cover (S 65 Only)

Comfort & Convenience

- COMAND NTG 5.5
- MAGIC VISION CONTROL
- Ambient Lighting in 64-colors with Individual Zones
- Active Multicontour Front Seats
- IWC® Clock in Dashboard
- NFC Wireless Charging Front
- ENERGIZING COMFORT Function
- Smartphone Integration with Apple CarPlay and Android Auto
- Soft-close doors and electronic trunk closer
- Touch Control Buttons on steering wheel
- Panorama Roof
- New generation SmartKey with Affalterbach Crest
- DINAMICA Headliner (S 63 Only)
- Nappa Leather Headliner (S 65 Only)
- AMG Metal Emblem in trim element (S 65 Only)
- Burmester® High-End 3D Surround Sound System (S 65 Only)

Safety & Security

- Lane Tracking Package (Blind Spot Assist & Lane Keep Assist)
- Surround View System
- Active Brake Assist
- LED Intelligent Light System
- ATTENTION ASSIST
- Active Parking Assist
- mbrace® with trial period by Verizon Telematics
- LED Taillights with crystal look
- Surround View System (S 65 Only)
- Night View Assist PLUS (S 65 Only)

Exterior Paint Colors



Non-metallic Paints

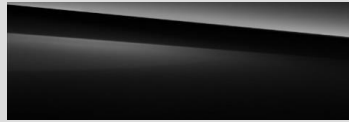

040
Black
Option price: \$0

Metallic Paints & Magno Paints



183
Magnetite Black
Option price: \$0

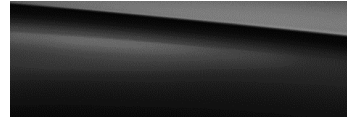

197
Obsidian Black
Option price: \$0



775
Iridium Silver
Option price: \$0



890
Lunar Blue
Option price: \$0



988
Diamond Silver
Option price: \$0



998
Anthracite Blue
Option price: \$0



989
Emerald Green
Option price: \$0



992
Selenite Grey
Option price: \$0

designo® Paints



799
Diamond White
Option price: \$795



049
Cashmere White Magno
Option price: \$3,950

Wheels



654
20" AMG 5-Spoke Wheels
Titanium
Option price: \$0 (S63 Only)
R01, B51



647
20" AMG Forged 10-Spoke
Wheels, Silver
Option price: \$1,700 S63, \$0 S65
R01, B51



648
20" AMG Forged 10-Spoke
Wheels, Black
Option price: \$2,200 S63, \$0 S65
R01, B51



RTR
20" AMG Forged Cross-Spoke
Wheels, Silver
Option price: \$1,700 S63, \$0 S65
R01, B51



RTS
20" AMG Forged Cross-Spoke
Wheels, Black
Option price: \$2,200 S63, \$0 S65
R01, B51



696
20" AMG Forged Multi Spoke
Wheels, High-Polished
Option price: \$0 (S65 Only)
R01, B51



753
20" AMG Forged Twin 5-Spoke
Wheels, Silver with Black Accents
Option price: \$1,700 S63, \$0 S65
R01, B51

Wheels



Code	Wheel Size	Description	Wheel Dimensions	Mobility	Availability	MSRP
654	20"	AMG 5-Spoke Wheels, Titanium w/ black Accents	255/40 R 20 on 8.5 J x 20 ET39 (Front) 285/35 R 20 on 9.5 J x 20 ET39 (Rear)	R01, B51	S 63	\$0
647	20"	AMG Forged 10-Spoke Wheels, Silver	255/40 R 20 on 8.5 J x 20 ET39 (Front) 285/35 R 20 on 9.5 J x 20 ET39 (Rear)	R01, B51	S 63 S 65	\$1,700 \$0
648	20"	AMG Forged 10-Spoke Wheels, Black	255/40 R 20 on 8.5 J x 20 ET39 (Front) 285/35 R 20 on 9.5 J x 20 ET39 (Rear)	R01, B51	S 63 S 65	\$2,200 \$0
RTR	20"	AMG Forged Cross-Spoke Wheels, Silver	255/40 R 20 on 8.5 J x 20 ET39 (Front) 285/35 R 20 on 9.5 J x 20 ET39 (Rear)	R01, B51	S 63 S 65	\$1,700 \$0
RTS	20"	AMG Forged Cross-Spoke Wheels, Black	255/40 R 20 on 8.5 J x 20 ET39 (Front) 285/35 R 20 on 9.5 J x 20 ET39 (Rear)	R01, B51	S 63 S 65	\$2,200 \$0
753	20"	20" AMG 5-Twin-Spoke Forged Wheels, Silver with Black Accents	255/40 R 20 on 8.5 J x 20 ET39 (Front) 285/35 R 20 on 9.5 J x 20 ET39 (Rear)	R01, B51	S 63 S 65	\$1,700 \$0
696	20"	AMG Forged Multi Spoke Wheels	255/40 R 20 on 8.5 J x 20 ET39 (Front) 285/35 R 20 on 9.5 J x 20 ET39 (Rear)	R01, B51	S 65	\$0

Interior Upholstery – Nappa Leather



851
Black

Option price: \$0 S 63, n/a S 65

61U Black or 68U Crystal Grey DINAMICA Headliner



855

Porcelain/Espresso Brown

Option price: \$0 S 63, n/a S 65

65U Porcelain DINAMICA Headliner

Interior Upholstery – *designo* Exclusive Nappa Leather



561

designo Black Exclusive Nappa Leather
61U Black or 68U Grey DINAMICA Headliner (S63)
71U Black or 78U Grey Nappa Leather Headliner (S65)
S63: \$3,250, S65: \$0



565

designo Porcelain/Esspresso Brown Exclusive Nappa Leather
65U Porcelain DINAMICA Headliner (S63)
75U Porcelain Nappa Leather Headliner (S65)
S63: \$3,250, S65: \$0



568

designo Crystal Grey/Black Exclusive Nappa Leather
61U Black or 68U Grey DINAMICA Headliner (S63)
71U Black or 78U Grey Nappa Leather Headliner (S65)
S63: \$3,250, S65: \$0



584

designo Saddle Brown/Black Exclusive Nappa Leather
61U Black DINAMICA Headliner (S63)
71U Black Nappa Leather Headliner (S65)
S63: \$3,250, S65: \$0



585

designo Porcelain/Deep-Sea Blue Exclusive Nappa Leather
65U Porcelain DINAMICA Headliner (S63)
75U Porcelain Nappa Leather Headliner (S65)
S63: \$3,250, S65: \$0



595

designo Porcelain/Titian Red Exclusive Nappa Leather
65U Porcelain DINAMICA Headliner (S63)
75U Porcelain Nappa Leather Headliner (S65)
S63: \$3,250, S65: \$0

Interior Upholstery – *designo* Exclusive Nappa Leather



567

designo Bengal Red/Black Exclusive Nappa Leather

61U Black DINAMICA Headliner (S63)

71U Black Nappa Leather Headliner (S65)

S63: \$3,250, S65: \$0

Interior Upholstery



<i>Code</i>	<i>Upholstery</i>	<i>Seats</i>	<i>Floor Mats</i>	<i>Upper Dash/Lower Dash</i>	<i>Seat Belts</i>	<i>Steering Wheel</i>	<i>Headliner</i>
851	Nappa Leather Black	Black	Black	Black	Black	Black	Black or Crystal Grey
855	Nappa Leather Porcelain/ Espresso Brown	Porcelain	Porcelain	Espresso Brown/Porcelain	Porcelain	Porcelain	Porcelain
561	<i>designo</i> Black Exclusive Nappa Leather	Black	Black	Black/Black	Black	Black	Black
565	<i>designo</i> Porcelain/Espresso Brown Exclusive Nappa Leather	Porcelain	Porcelain	Espresso Brown/Porcelain	Porcelain	Porcelain	Porcelain
568	<i>designo</i> Crystal Grey/Black Exclusive Nappa Leather	Crystal Grey	Crystal Grey	Crystal Grey/Black	Crystal Grey	Black	Black or Crystal Grey
584	<i>designo</i> Saddle Brown/Black Exclusive Nappa Leather	Saddle Brown	Black	Black/Saddle Brown	Black	Black	Black
585	<i>designo</i> Porcelain/Deep Sea Blue Exclusive Nappa Leather	Porcelain	Porcelain	Deep Sea Blue/Porcelain	Porcelain	Porcelain	Porcelain
595	<i>designo</i> Porcelain/Titian Red Exclusive Nappa Leather	Porcelain	Porcelain	Tizian Red/Porcelain	Porcelain	Porcelain	Porcelain
567	<i>designo</i> Bengal Red/Black Exclusive Nappa Leather	Bengal Red	Black	Black/Bengal Red	Black	Black	Black

Interior Trims



729

Black High-gloss Poplar Wood
Option Price: *No charge*



H29

Brown High-gloss Burl Walnut Wood
Option Price: *No charge*

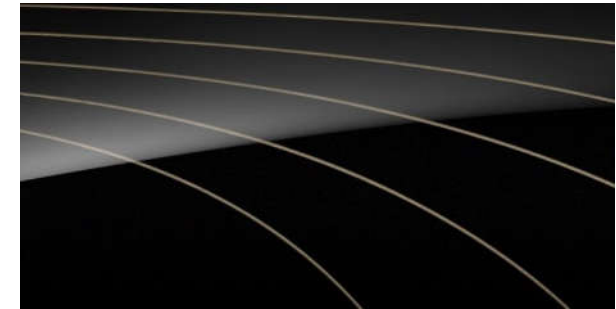

H16

designo Black Piano Lacquer Flowing Lines
Option Price: *\$1,300*



H21

designo Black Piano Lacquer
Option Price: *\$800*



H30

Grey Satin-Finish Ash Wood
Option Price: *\$800*



H26

designo Magnolia Flowing Lines
Option Price: *\$1,300*

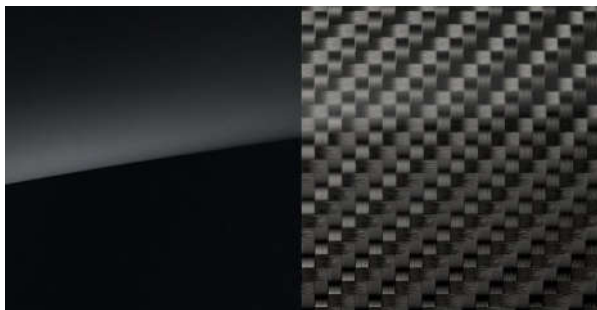

H10

AMG Carbon Fiber & Black Piano Lacquer

Option Price: \$3,700

New Trim Options



Grey Satin-Finish Ash Wood (H30)



Brown High-gloss Burl Walnut Wood (H29)



designo Magnolia Flowing Lines (H26)

Option Packages



<i>Code</i>	<i>Packages</i>	<i>Availability</i>	<i>MSRP</i>
P01	Premium Package <ul style="list-style-type: none"> ▪ 432 – Multicontour Front Seats with Massage Feature ▪ 463 – Head-Up Display ▪ 501 – Surround View System ▪ 902 – Front Variable Heated Seats Plus 	S 63	\$ Standard
		S 65	\$ Standard
445	Warmth and Comfort Package <ul style="list-style-type: none"> ▪ 443 – Heated Steering Wheel ▪ P68 – Heated Front Door Panels and Center Console ▪ 872 – Heated Rear Seats 	S63	\$ 1,990
		S65	\$ Standard
997	Driver Assistance Package <ul style="list-style-type: none"> ▪ Active Lane Change Assist ▪ Extended Restart in Stop-and-Go Traffic ▪ Route-Based Speed Adaption ▪ Active Distance Assist DISTRONIC ▪ Active Steering Assist ▪ Active Speed Limit Assist 	S 63	\$ 2,250
		S 65	\$ Standard
773	AMG Exterior Carbon Fiber Package <ul style="list-style-type: none"> • Carbon Fiber Lower front A-wing blade • Carbon Fiber Lower rear apron • Carbon Fiber Side View Mirror covers • Carbon Fiber Rocker panel insert • S63: Carbon Fiber Engine Cover 	S63	\$ 6,500
		S65	\$ 5,300

Stand-Alone Options



<i>Code</i>	<i>Options</i>	<i>Availability</i>	<i>MSRP</i>
B07	AMG Ceramic Compound Braking System	All Models	\$ 8,950
308	Refrigerated compartment in the rear	All Models	\$ 1,100
597	Heated Windshield	All Models	\$ 550
U70	AMG Red-Painted Brake Calipers	All Models	\$ 700
P60	AMG Night Styling Package <ul style="list-style-type: none"> • High-gloss black lower front A-wing blade • High-gloss black lower rear apron trim • High-gloss black Side View Mirror covers • High-gloss black Rocker panel insert • Black chrome tailpipes • S65 Only: High-gloss black mesh front grilles, forces 5U2 Note: May be combined with 773 Carbon Fiber Exterior Package	All Models	\$ 750
811	Burmester® High-End 3D Surround Sound System	S63	\$ 6,400
398	MAGIC SKY CONTROL	S65	\$ 2,500
610	Night View Assist PLUS (Requires 997 Driver Assistance Package)	S63	\$ 2,260
5U5	Swarovski® Crystal Headlamps (Requires 610)	S63	\$ 1,750
B14	AMG Carbon Fiber Engine Cover	S63	\$ 1,500
P34	Exclusive Interior Control Code (Required for 5XX Exclusive Nappa Leather Interiors)	S63	\$ 0
5U2	High-Gloss Black Air Intakes, Air Flics, and Mesh Grille (Required with P60)	S65	\$ 0
<i>Code</i>	<i>VPC Installed Accessories</i>	<i>Availability</i>	<i>MSRP</i>
068	Wheel Locks	All Models	\$ 150