

Model 207, 212
as of model year 2014
with code U60 (Pedestrian protection - Active hood)

Model 217, 222
with code U60 (Pedestrian protection - Active hood)

Modification notes

27.07.2017	Method description adjusted to model 222 from model year 2018.	Operation steps 4.1 and 4.2.	
------------	--	------------------------------	--

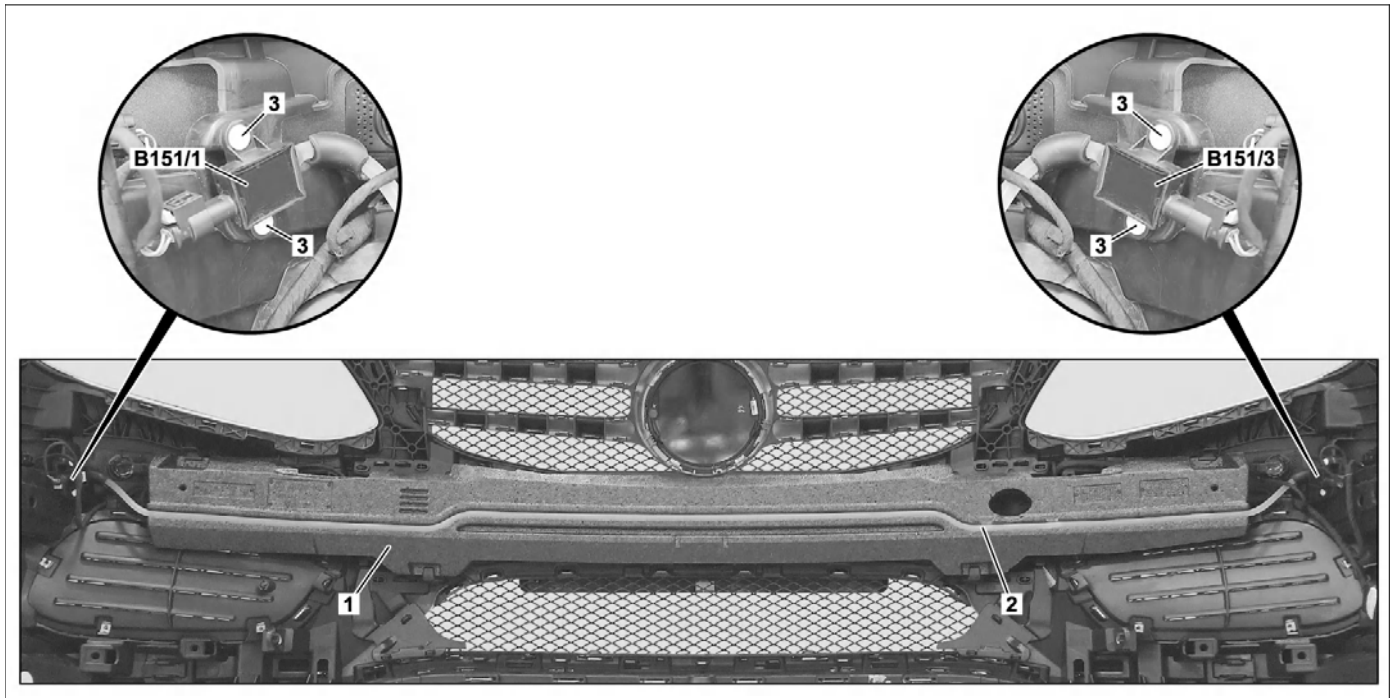

P91.60-4497-09

Shown on model 212.001

1 Impact absorber
2 Hose
3 Expansion rivet

B151/1 Left front bumper pedestrian protection sensor
B151/3 Right front bumper pedestrian protection sensor

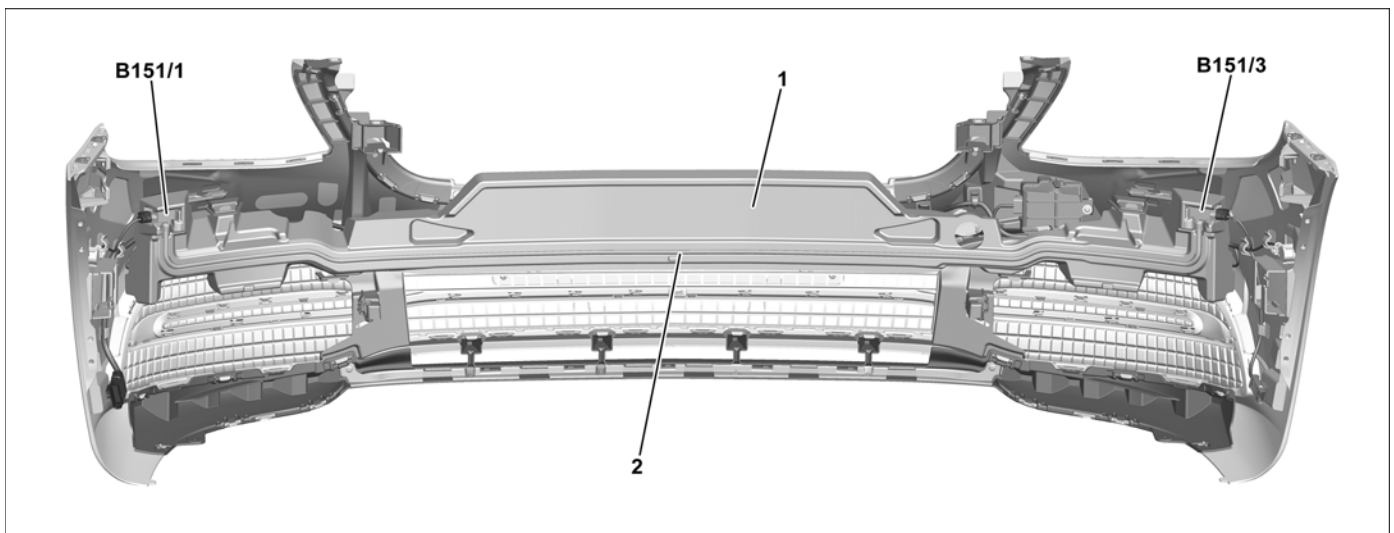





P91.60-5193-08

Shown on model 222.0 from model year 2018

1 Impact absorber
2 Hose

B151/1 Left front bumper pedestrian protection sensor
B151/3 Right front bumper pedestrian protection sensor

	Information on preventing damage to electronic components due to electrostatic discharge		AH54.00-P-0001-01A
	General information on the impact absorber		AH88.20-P-1000-01A
	Notes on pedestrian protection sensor		AH91.60-P-0001-01A
	Remove/install		
1	Remove front bumper	Model 217 with code U60 (Pedestrian protection - Active hood) Model 207 as of model year 2014 with code U60 (Pedestrian protection - Active hood) Model 212 as of model year 2014 with code U60 (Pedestrian protection - Active hood) Model 222 with code U60 (Pedestrian protection - Active hood)	AR88.20-P-2000LC AR88.20-P-2000EW AR88.20-P-2000EWM AR88.20-P-2000LF
2	Disconnect electrical connectors from left front bumper pedestrian protection sensor (B151/1) and right front bumper pedestrian protection sensor (B151/3)		
3	Remove hose (2) from groove in impact absorber (1)	 Installation: Ensure that hose (2) is seated correctly in impact absorber (1). Route the hose (2) without voltage and kinks. Malfunctions can occur otherwise.  Installation: Insert hose (2) as deep as possible in groove of impact absorber (1).  Model 207, 212 as of model year 2014 with code U60 (Pedestrian protection - Active hood) Model 217, 222 up to model year 2018 with code U60 (Pedestrian protection - Active hood) Installation: Hose (2) must protrude the same amount at left and right at impact absorber (1).	
4.1	Remove expansion rivet (3) and remove left front bumper pedestrian protection sensor (B151/1) and right front bumper pedestrian protection sensor (B151/3) together with hose (2)	Model 207, 212 as of model year 2014 with code U60 (Pedestrian protection - Active hood) Model 217, 222 up to model year 2018 with code U60 (Pedestrian protection - Active hood)  Do not disconnect left front bumper pedestrian protection sensor (B151/1) and right front bumper pedestrian protection sensor (B151/3) from hose (2). Malfunctions can occur otherwise.	
4.2	Remove left front bumper pedestrian protection sensor (B151/1) and right front bumper pedestrian protection sensor (B151/3) from impact absorber (1) together with hose (2)	Model 217, 222 as of model year 2018 with code U60 (Pedestrian protection - Active hood)  Do not disconnect left front bumper pedestrian protection sensor (B151/1) and right front bumper pedestrian protection sensor (B151/3) from hose (2). Malfunctions can occur otherwise.	
5	Install in the reverse order		