

Transmission	722.617 in MODEL 220.063
Transmission	722.618 in MODEL 220.065 /165
Transmission	722.626 in MODEL 220.026
Transmission	722.628 in MODELS 215.378, 220.178 /878
Transmission	722.632 in MODEL 220.070 /170
Transmission	722.633 in MODELS 215.375, 220.075 /175 /875
Transmission	722.639 in MODEL 220.028 /128
Transmission	722.636 in MODELS 215.373, 220.073 /173
Transmission	722.6 in MODEL 230

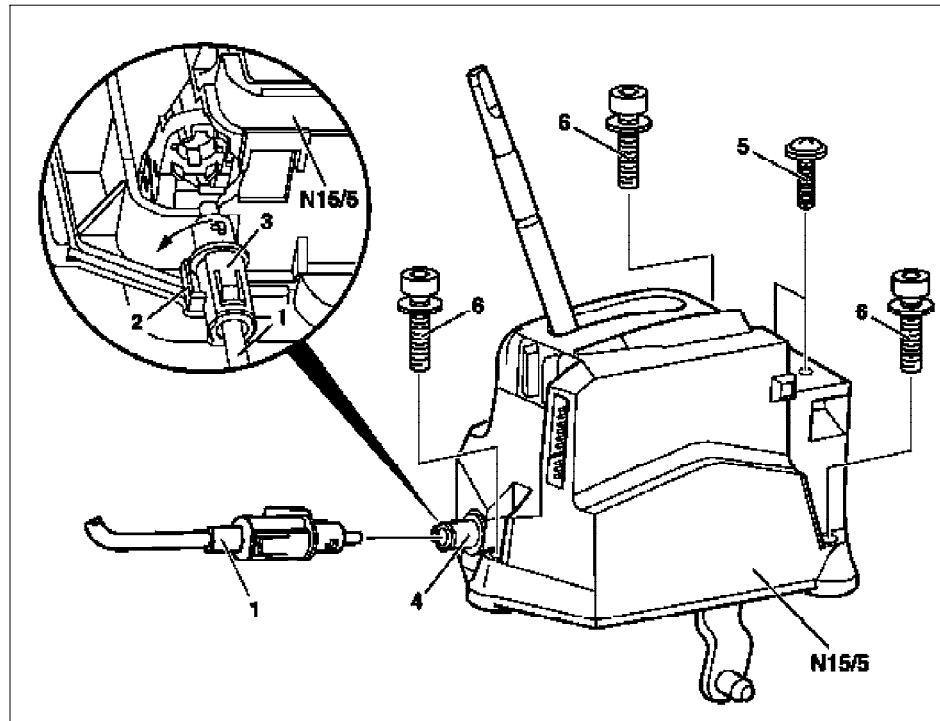

- 1 Ignition lock control cable  
 2 Locking plate  
 3 Clutch  
 4 Cable connection fitting  
 5 Bolt  
 6 Bolt

N15/5 Electronic selector lever module control unit



P27.60-2686-06

	Remove/install		
	Notes on self-locking nuts and bolts		AH00.00-N-0001-01A
	Information on preventing damage to electronic components due to electrostatic discharge		AH54.00-P-0001-01A
1	Unhook head on intermediate lever	See ~ Remove/install and adjust shift rod: Model 230 Model 215, 220	AR27.60-P-0990R AR27.60-P-0990I
2.1	Remove cover on center console	Model 230 up to 14.1.04 Model 230 as of 15.1.04	AR68.20-P-2350R AR68.20-P-2350RA
2.2	Remove center console	Model 215 Model 220	AR68.20-P-2000N AR68.20-P-2000M
3.1	Remove air duct for center rear compartment air nozzle	Only on model 215, 220 without rear air conditioner, code 582	
4.1	Remove bolts (5)	Only for model 230	
5	Remove bolts (6)	On model 230 use Allen wrench with ball head. <b>Installation:</b> Replace self-locking bolts (6). 	*BA27.60-P-1001-02A
6	Detach electric plugs on electronic selector lever module control unit (N15/5)		

7	Raise locking lug (2), press coupling (3) over the cable connection fitting (4) against the spring force, turn the coupling (3) through 90° (arrow) and detach ignition switch cable (1) from electronic selector lever module control unit (N15/5)		
8	Remove electronic selector lever module control unit (N15/5).	<p> On model 230 raise rear center console</p> <p> <b>Installation:</b> Pay attention to electrical lines.</p>	
9	Install in the reverse order		
10	Read out fault memory with STAR DIAGNOSIS and erase if necessary.	STAR DIAGNOSIS diagnosis system	*WE58.40-Z-1013-06A
11	Carry out function check of electronic selector lever module control unit (N15/5)		

 **Tightening torques for floor shift**

Number	Designation	Transmis- sion 722.6
BA27.60-P-1001-02A	Bolt, floor selector to body	Nm 6

**Workshop equipment/MB testers** (see Workshop Equipment Manual)

WE58.40-Z-1013-06A	STAR DIAGNOSIS Compact diagnosis system for passenger cars, order number 6511 1801 00
--------------------	---