



Date: February 7, 2012  
Order No.: S-B-54.65/251  
Group: 54

**SUBJECT: MY-All, All Models with Code 220 Parktronic system (PTS); Code EZ8; Code 230 Advanced Parking Guidance; Code 235 Active Park Assist; Code EZ8 Parktronic system (PTS)  
Parktronic Sensor Return Policy**

Do not replace any Parktronic sensor under warranty that has (Figure 1) (A) (B) parking dents, stone chipping, or the like on the diaphragm cup – the painted part of the sensor.

In addition, perform a control log or quick test before replacing any sensor without external damage.

Mark the installation position (Figure 2) on the returned sensor and include the following when returning any Parktronic control unit, Parktronic sensor, or Parktronic warning indicator under warranty:

- Part return slip (ARS) (for residual market operations a return delivery document is also required)
- Control Unit Log

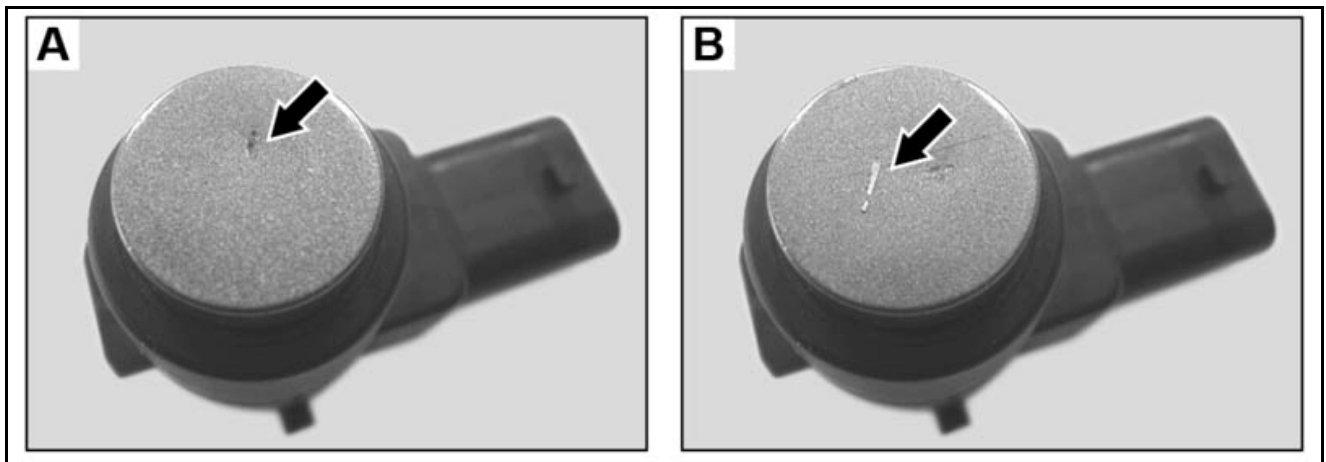

**Figure 1. External damage through parking dents, stone chipping, etc.**

P54.65-4739-04

This bulletin has been created and maintained in accordance with MBUSA-SLP S423QH001, Document and Data Control, and MBUSA-SLP S424HH001, Control of Quality Records.

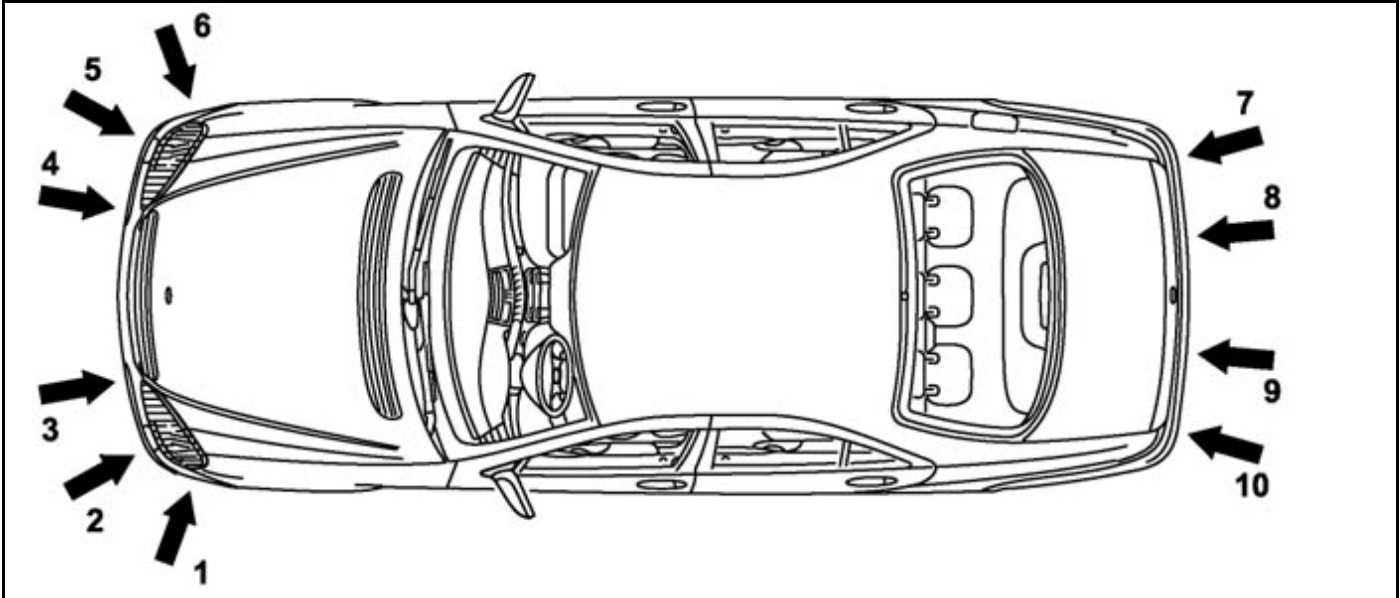

Figure 2. Sensor units on vehicle – positions 1-10.

P54.65-4740-05