

**ENGINE 272, 273**

**Nm** Coolant pump, coolant thermostat

Number	Designation				ENGINE 272	ENGINE 273
BA20.10-P-1002-01U	Bolt, coolant pump to cylinder crankcase	M8	Stage 1	Nm	5	5
			Stage 2	Nm	20	20

**Nm** Coolant pump, coolant thermostat

Number	Designation				ENGINE 272	ENGINE 273
BA20.10-P-1001-01U	Self-tapping bolt connecting coolant pump to timing case cover	M7	Stage 1	Nm	10	10
			Stage 2	Nm	25	25

**Tightening sequence and bolt length**

**!** The tightening sequence arising from the operation steps and prescribed screw length should be observed.

Leakage of the coolant pump can occur otherwise.

**i** Bolt assignment of coolant pump

Screw/bolts A: Coolant pump to timing case cover.

Screw/bolts B and C: Coolant pump on cylinder crankcase.

- 1 Tighten down screw/bolts 1A to 8A (M7×28) numerically ascending **Nm** .
- 2 Tighten screw/bolts B (M8×75) **Nm** .
- 3 Tighten screw/bolts C (M8×110) **Nm** .

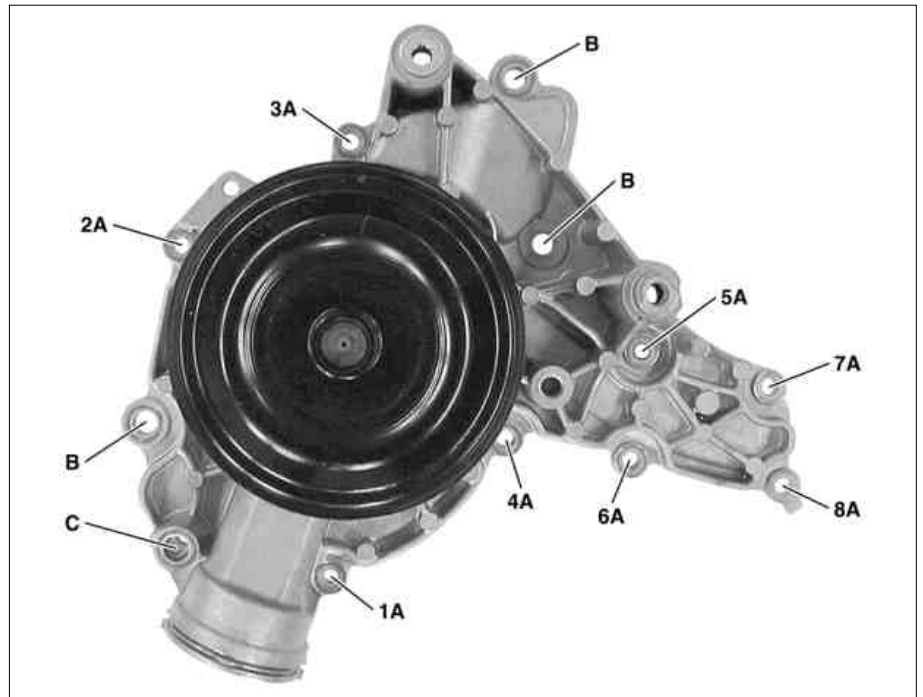

P20.10-2143-06