

- Model 117.3**
- Model 166, 172.4, 218**
- Model 212.0/2**
- Model 222**
- Model 242, 246**
with code 362 (HERMES LTE)
with code 460 (Canada version)
- Model 242, 246**
with code 362 (HERMES LTE)
with code 494 (US version)
- Model 242, 246**
with code 536 (SIRIUS satellite radio)
- Model 292**

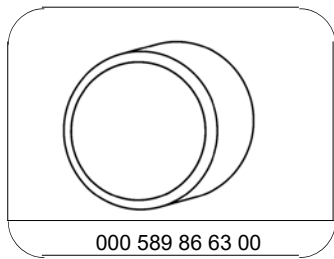

Adapter

Repair materials

Number	Designation	Order number
BR00.45-Z-1135-02A	Repair kit for installing windshields, 1-component adhesive	A 221 670 81 01

1 Clean bonding area at cover (1) with the cleaning cloth included in the repair kit and wipe again using dry cloth.

ⓘ The bonding area on the cover (1) must be absolutely free of dust and grease. Otherwise the adhesive force of the glue starts to decrease.

2 Center application nozzle over flange of cover (1) and evenly apply adhesive material in the process.

ⓘ The adhesive bead (2) must have a diameter of 4 mm, it must not exhibit any discontinuities and it must be applied in the front area with an overlap (3) of approx. 10 mm. Otherwise leaktightness and strength are not assured.

3 Completely press adhesive residues not required out of cartridge using the ⓘ adapter and dispose of.

ⓘ ⓘ Insert adapter between cartridge piston and plate on push rod of cartridge gun.

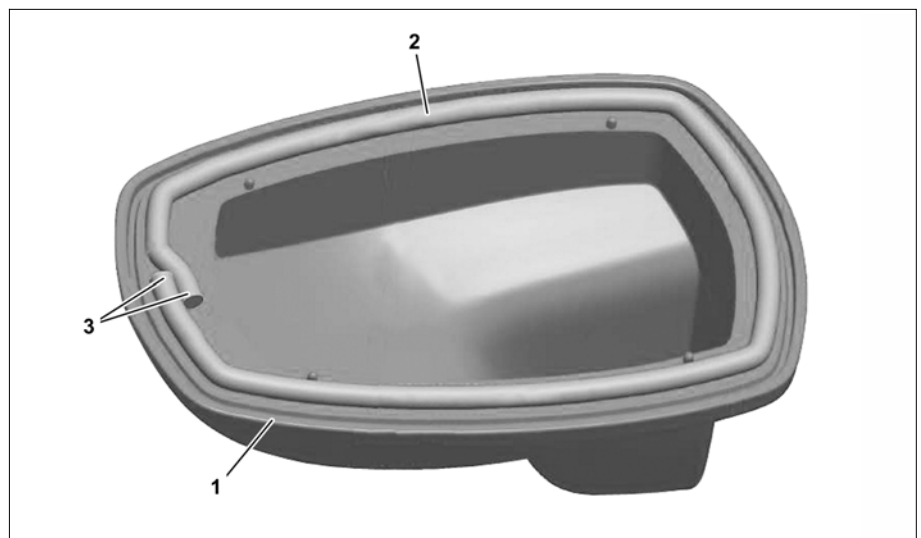

P82.62-3675-05

⚠ The cover (1) must be mounted onto the body within a period of 5 minutes after applying the adhesive material. Otherwise the adhesive force of the glue starts to decrease.