

- Parts list -

Mode	BM mode	BM overview	CL 500 4MATIC / CL 550 4MATIC USA/JAPAN
VIN/mod. des.	WDD2163861A025078	Catalog	65V
VIN	WDDEJ8GB3AA025078	Group	33 FRONT AXLE
Sales designation		Sub-group	090 4MATIC FRONT AXLE SHAFT
Assortment class	PC		
Market			

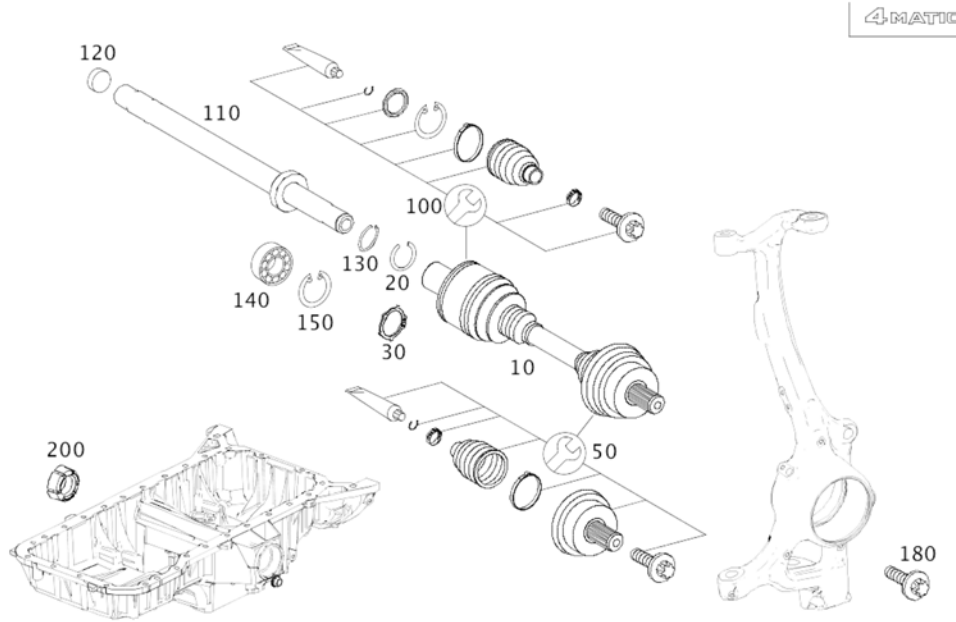



























Image ID: drawing_B3309000023

Copyright 2018-12-23 Daimler AG

Item	Part number	Designation/additional information	Qty
------	-------------	------------------------------------	-----

Item	Part number	Designation/additional information	Qty
10	A 221 330 12 01	DRIVE SHAFT LEFT  Code: M005;	1
10	A 221 330 14 01	DRIVE SHAFT LEFT  Code: M005;	1
10	A 221 330 16 01	DRIVE SHAFT LEFT  Code: M005;	1
10	A 221 330 63 00	DRIVE SHAFT LEFT  Code: M005;  [697] PART IS ONLY OR ALSO SUPPLIED AS RECONDITION...	1
10	A 221 330 13 01	DRIVE SHAFT RIGHT  Code: M005;	1
10	A 221 330 15 01	DRIVE SHAFT RIGHT  Code: M005;	1
10	A 221 330 23 01	DRIVE SHAFT RIGHT  Code: M005;	1
10	A 221 330 64 00	DRIVE SHAFT RIGHT  Code: M005;  [697] PART IS ONLY OR ALSO SUPPLIED AS RECONDITION...	1
20	N 000983 020000	* RETAINING RING DRIVE SHAFT; 20X1.2  Code: M005;	1
30	N 000983 020000	* RETAINING RING DRIVE SHAFT; 20X1.2  Code: M005;	1
50	A 221 330 01 85	RS COLLAR OUTSIDE  Code: M005;	1
50	A 204 330 05 85	RS ELASTOMERIC BOOT OUTSIDE  Code: M005;	1
50	A 221 330 01 85	RS COLLAR OUTSIDE  Code: M005;	1

Copyright 2018-12-23 Daimler AG

Item	Part number	Designation/additional information	Qty
50	A 204 330 05 85	RS ELASTOMERIC BOOT OUTSIDE  Code: M005;	1
100	A 221 330 02 85	RS BOOT INSIDE  Code: M005;	1
100	A 221 330 02 85	RS BOOT INSIDE  Code: M005;	1
110	A 221 330 07 01	INTERMEDIATE SHAFT  Code: M005;	1
120	N 000443 017000	* CAP INTERMEDIATE SHAFT  Code: M005;	1
130	A 112 994 09 35	* SNAP RING INTERMEDIATE SHAFT  Code: M005;	1
140	A 112 980 01 15	* DEEP-GROOVE BALL BEARING INTERMEDIATE SHAFT  Code: M005;	1
150	N 000472 055000	RETAINING RING INTERMEDIATE SHAFT BEARING IN OIL PAN; 55X2  Code: M005;	1
180	A 000 990 75 03	SCREW WITH FEATURE PROPELLER SHAFT TO FLANGE; M16X60  Code: M005;	2
200	A 272 014 00 50	PILOT BUSHING AT OIL PAN  Code: (M273+M55/M278)+M005;	1