

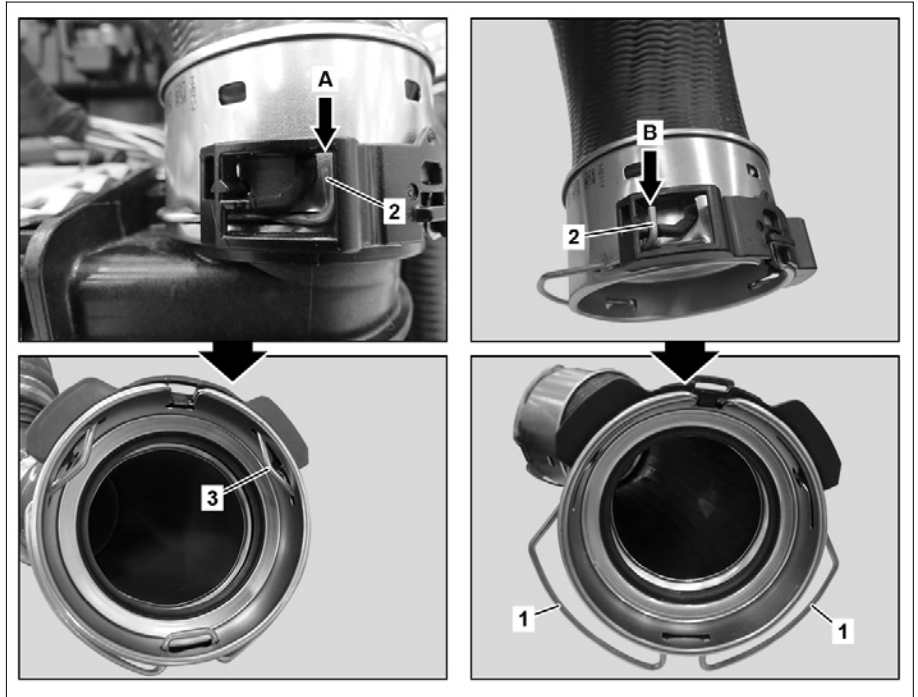

Engine 133, 139, 152, 156, 157, 176, 177, 178, 256, 260, 264, 266, 270, 271, 272, 273, 274, 275, 276, 277, 278, 279, 282, 607, 608, 626, 629, 640, 642, 646, 651, 654, 656, 780

Shown on variant 1



P09.41-3041-06

Open clutch

- 1 Slide nose (2) of catch spring (3) to position (B).
 Never pull on the eyelet (1). The catch spring (3) will lose its pretension otherwise.

- 2 Detach hose from component part.
- 3 Check sealing ring for damage.

If damage is present,

Replace hose.



Close clutch

- 4 Slide nose (2) of catch spring (3) to position (A).
- 5 Slide hose onto component until the catch spring (3) latches.
 Ensure connections are clean and free of grease.
- 6 Check connection by pulling a little at the hose.

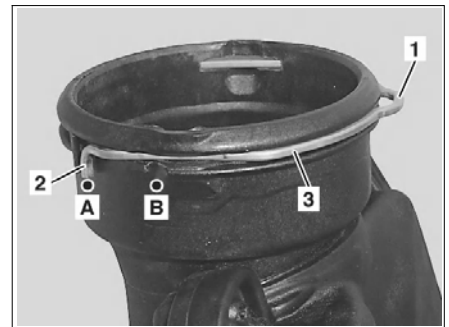

P09.41-2318-01

Shown on variant 2