

Service Campaign Bulletin



Mercedes-Benz

Campaign No. 2015030006, June 2015

Revision	Date	Purpose
B	06/10/15	Inclusion of power electronics return information
A	06/04/15	Inclusion of Customer Letter
-	04/29/15	Initial release

TO: ALL MERCEDES-BENZ CENTERS

SUBJECT: **Model 221, Model Year 2010**
Replace Power Electronics

Daimler AG (DAG), the manufacturer of Mercedes-Benz vehicles, has determined a loss of capacity in the PCC capacitor of the power electronics may lead to deactivation of the hybrid function. To correct this condition an authorized Mercedes-Benz dealer will replace the power electronics at the next dealer visit.

Prior to performing this Service Campaign:

- Please check VMI to determine if the vehicle is involved in the Campaign and if it has been previously repaired.
- Please review the entire Service Campaign bulletin and follow the repair procedure exactly as described.

Approximately 60 vehicles are affected.

Order No. P-SC-2015030006

This bulletin has been created and maintained in accordance with MBUSA-SLP S423QH001, Document and Data Control, and MBUSA-SLP S424HH001, Control of Quality Records.

Procedure

Note:

- Use DAS/Xentry 03-04/2015 with all associated patches or higher
- Follow the steps exactly as described in DAS/Xentry
- Connect battery charger (battery voltage  >12.5V).

1. Refer to WIS: AR08.10-P-0011SXH and the additional following information.



WARNING!

- Secure work area with high voltage warning tape and cones (Figure 1).
- Follow all safety precautions and notes in above WIS instructions.

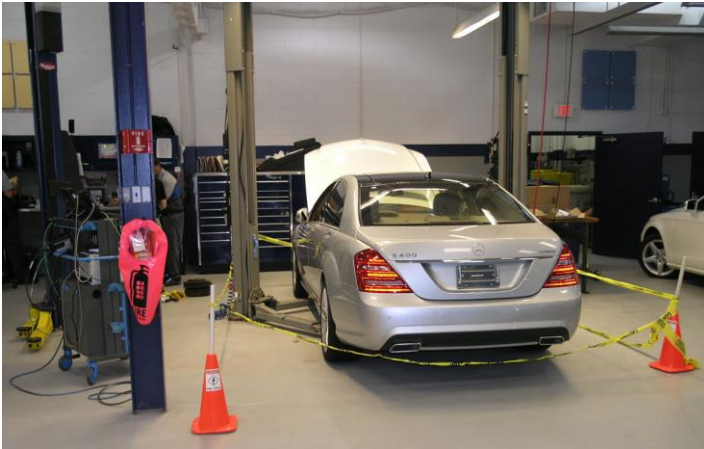

Figure 1

Note (regarding above WIS instructions)

- Please refer also to Figure 2 when disconnecting high voltage battery connector from high voltage battery (step 5 of WIS: AR08.10-P-0011SXH).



Figure 2 (supplemental illustration for WIS instructions)

- 2 High voltage battery connector
- 2a Screw
- 2b Bracket

- Note installed position of power electronics cable connector in relationship to air conditioning compressor connector **prior to disconnecting** cable (step 7 of WIS: AR08.10-P-0011SXH). This cable connector has only one installed position.

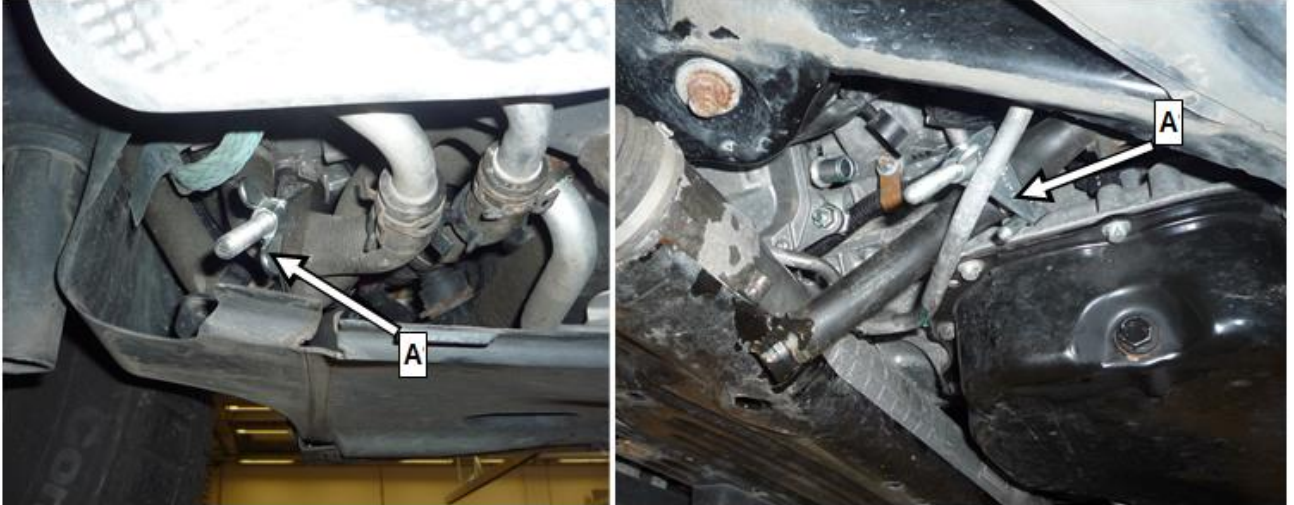

Figure 3

- It is not necessary to completely drain the coolant. Clamp off the coolant lines with hose clamp tool (A, Figure 3) in the area of the power electronics.
- It is sufficient to only drain approx. 0.2 liters the coolant from the power electronics.
- Removal of the front engine compartment paneling is not necessary
- Remove lower bolt from right front motor mount and lift engine slightly with under hoist jack stand in order to allow additional clearance when removing power electronics module. Torque bolt to 35 Nm when reinstalling

⚠ WARNING!

Risk of vehicle falling off vehicle lift. Be careful not to raise vehicle off of vehicle lift when raising engine with under hoist jack stand.

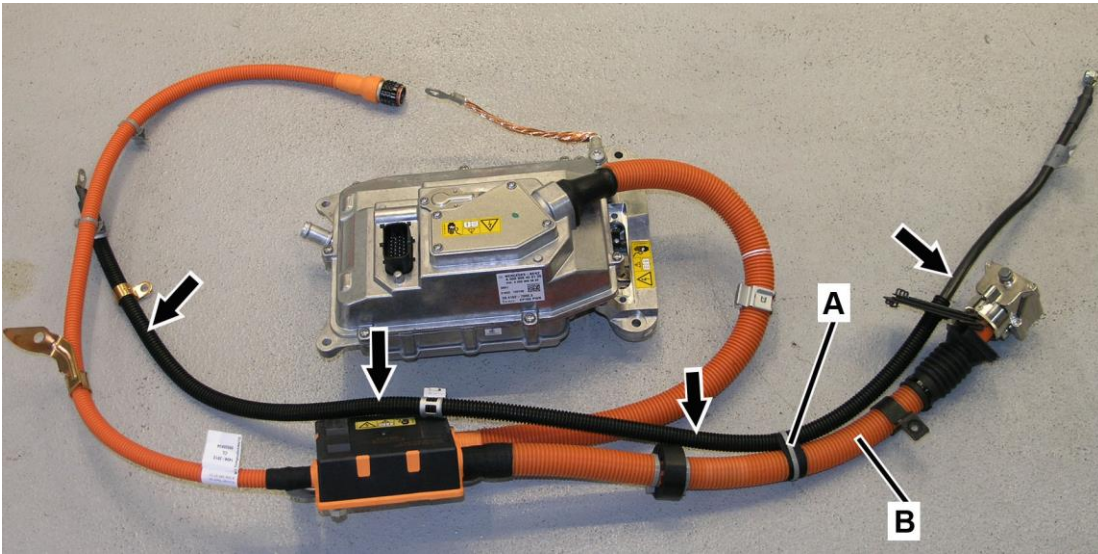

Figure 4

- Do not remove the existing alternator cable (arrows, Figure 4) from vehicle when removing power electronics module. Cut cable tie (A) to detach existing alternator cable (arrows) from old power electronics cable (B) and leave existing alternator cable (arrows) on vehicle
- Prior to installing **new** power electronics module, cut cable tie (A, Figure 4) and remove **new** alternator cable (arrows) attached to **new** power electronics module cable (B). The **new** alternator cable (arrows) does not get installed on vehicle.



IMPORTANT: Secure original alternator cable (arrows) to same position on **new** power electronics cable (B) with **new** cable tie (A) after installing power control module. Be sure to use **only** the cable tie listed in parts table.

- Top-off coolant (shop supply)
- Thoroughly evacuate coolant from removed (old) power electronics module, seal openings and send back in original box.

Note (regarding WIS documents referenced in this Procedure):

- Replacement of parts **not** listed in the parts table of this Procedure **or** not listed in WIS: AR08.10-P-0011SXH are **not** claimable under this campaign. Parts listed in WIS documents **referenced** in WIS: AR08.10-P-0011SXH are also **not** claimable under this campaign. If replacement of additional part(s) is necessary, check coverage prior to submitting under warranty.
- Parts listed in WIS: AR08.10-P-0011SXH are only to be replaced **if necessary**.

Note:

Thoroughly evacuate coolant from removed power electronics module and seal openings. Return power electronics module in original box.

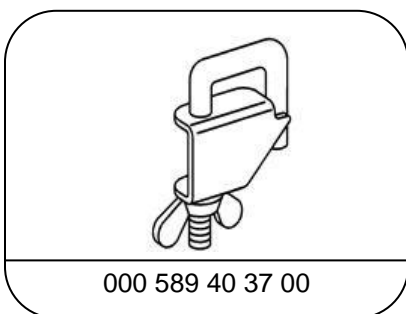
 **Special Tools**

Hose clamp (or equivalent)

Primary Parts Information

Qty.	Part Name	Part Number	Estimated Replacement Rate
1	AC drive	A 000 906 47 03	100%
1	Cable tie	A 000 995 29 94	
2	Nuts (exhaust hanger)	A 112 142 00 72	
2	Bolts (exhaust head pipe to manifold)	A 170 990 00 10	
1 (if req.) *	Housing Cover	A 000 150 00 67	1%
1 (if req.) *	Housing Cover	A 000 150 01 67	

* Replace housing cover if O-ring is damaged.

 **Note:**

- Please be aware that only the part number(s) referenced in the Campaign Bulletin is/are approved for use to repair the vehicle. Repairs performed using any other part(s) will not have been performed in accordance with the campaign. Accordingly, warranty claims submitted with reference to an improper part number(s) will be denied.
- The following allowable labor operation should be used when submitting a warranty claim for this repair:

Warranty Information

Operation: Replace power electronics Includes: Connect DAS, enable high voltage system and connect battery charger (02-8931)

Damage Code	Operation Number	Labor Time (hrs.)
08 930 32 7	02-8931	3.9



Mercedes-Benz

Service Campaign # 2015030006
Replace Power Electronics

Mercedes-Benz USA, LLC

Gareth Joyce

Vice President
Customer Services

May, 2015

Dear Mercedes-Benz Owner,

On behalf of Mercedes-Benz USA, I wanted to take a moment to thank you for choosing Mercedes-Benz. We hope that you're enjoying your 2010 S-Class Hybrid. Here at Mercedes-Benz USA, we are committed to delivering an exceptional ownership experience. In our continuing efforts to ensure the proper performance of your vehicle, we are writing to inform you about an issue regarding your vehicle. We have found that a loss of capacity of the vehicle's power electronics may lead to a failure of the hybrid function. When the power electronics do not have full capacity, the message "Ready" appears in yellow on the instrument cluster or as a red warning lamp with the battery symbol. Therefore we wish to replace the power electronics on your vehicle. Please contact an authorized Mercedes-Benz dealer who will replace the power electronics, free of charge.

For additional information and to schedule an appointment please contact **MERCEDES-BENZ OF ANYTOWN, 201-555-1234** or another authorized dealer, at your earliest convenience. To locate additional authorized dealers see www.MBUSA.com/dealerlocator. **Please mention you are scheduling an appointment to replace your power electronics under Service Campaign #2015030006.** You may be asked for your 17-digit Vehicle Identification Number (VIN) which, for your convenience, is located above your name at the top of this letter.

We are dedicated to always delivering the Best or Nothing – and respect for your time is a top priority. While the minimum repair time is approximately 1 day, your dealer can provide you with a better estimate of the overall time for this service visit. As a matter of normal service process, an authorized Mercedes-Benz dealer will also check for other repair measures which might be applicable to your vehicle and this may increase the required working time.

In the event that you are no longer the vehicle owner, or have had a change of address, please complete the reverse side and return the updated information in the enclosed envelope.

If for any reason a dealer is unable to remedy your situation, we are always happy to hear from you. Please contact us at 1-(800) FOR-MERCEDES (1-800-367-6372).

We sincerely apologize for any inconvenience this situation may cause you.

Sincerely,

Mercedes-Benz USA, LLC
One Mercedes Drive
P.O. Box 350
Montvale, NJ 07645-0350
Phone 1-800-FOR-MERCEDES (1-800-367-6372)
Fax (201) 476-6211
www.MBUSA.com

IMPORTANT

IF FOR ANY REASON YOU DO NOT NOW OWN THIS VEHICLE OR HAVE A CHANGE OF ADDRESS, PLEASE COMPLETE THE SECTION BELOW, PLACE IN THE ENCLOSED ENVELOPE, AND DROP IN ANY MAIL BOX. IF POSSIBLE, PROVIDE THE NAME AND ADDRESS OF THE PRESENT OWNER SO THAT WE MAY CONTACT THEM.

- SCRAPPED**
- STOLEN**
- OTHER** _____
- SOLD** _____ **I HAVE SOLD THE VEHICLE TO:**
- MY NEW ADDRESS IS:**

NAME _____

STREET _____ **APT.** _____

CITY _____ **STATE** _____ **ZIP** _____

PHONE _____

THANK YOU FOR YOUR COOPERATION

****** PLEASE DO NOT DETACH. RETURN COMPLETE LETTER ******
DO NOT USE THE ENCLOSED ENVELOPE FOR OTHER CORRESPONDENCE