

## - Parts list -

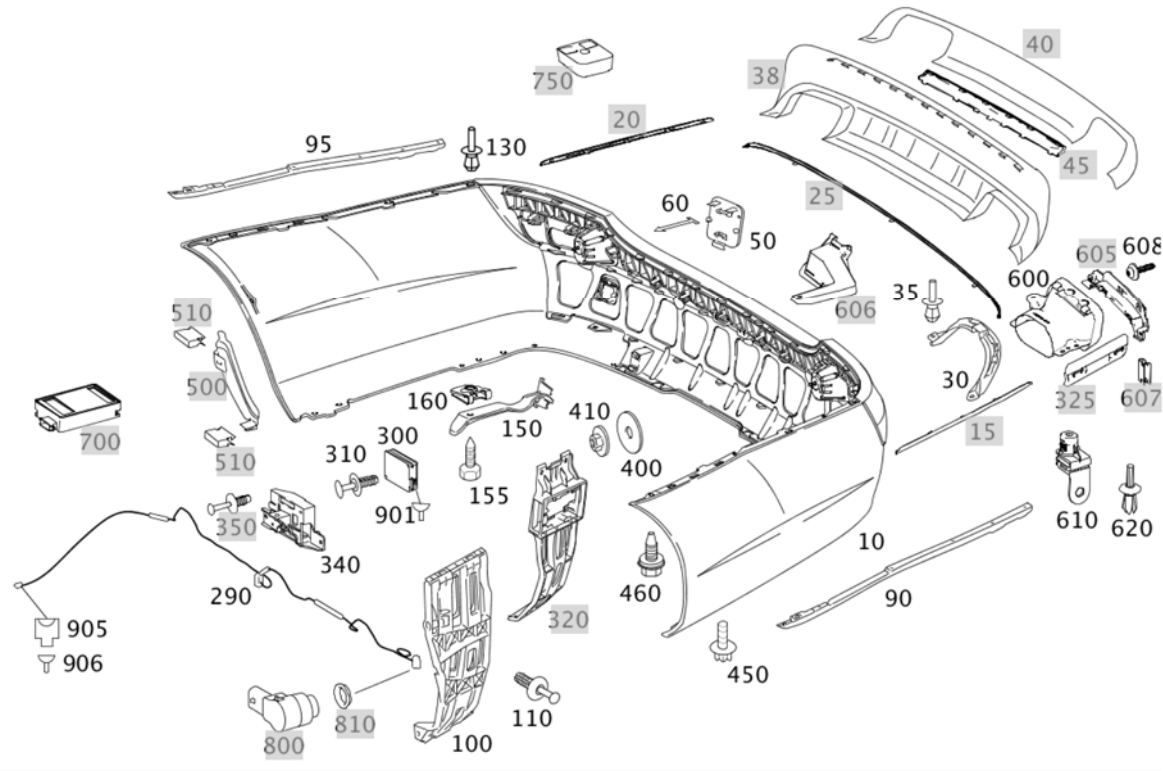

<b>Mode</b>	BM mode	<b>Market</b>	
<b>VIN/mod. des.</b>	WDD2211761A168460	<b>BM overview</b>	S 600
<b>VIN</b>	WDDNG76X28A168460	<b>Catalog</b>	63V
<b>Assortment class</b>	PC	<b>Group</b>	88 ATTACHMENT PARTS
		<b>Sub-group</b>	075 REAR BUMPER























Copyright 2020-06-28 Daimler AG

Image ID: drawing\_B88075000153

Item	Part number	Designation/additional information	Qty
------	-------------	------------------------------------	-----

Item	Part number	Designation/additional information	Qty
10	A 221 880 06 40	<b>TRIM</b> REAR BUMPER  Code: (264/460+264/835)+(M275+M55)+-220;  [420, 001637, 409] TO BE PAINTED PRIOR TO INSTALLATION  Plant information	1
30	A 221 885 09 22	<b>COVER</b> BUMPER BOTTOM LEFT  Code: (M275+M55)+(264/460+264/835)+-(772/800);  Plant information	1
30	A 221 885 10 22	<b>COVER</b> BUMPER BOTTOM RIGHT  Code: (264/460+264/835)+(M275+M55)+-772;  Plant information	1
35	A 000 990 25 92 9051	<b>EXPANSION RIVET</b> ORNAMENTAL COVER TO BUMPER  Code: (M275+M55)+-772;	6
50	A 221 885 11 23	<b>COVER</b> TOWING EYE  Code: (264/460+264/385)+-772;  Plant information	1
60	A 220 885 00 59	<b>BAND</b> COVER  Plant information	1
90	A 221 885 01 16	<b>REINFORCEMENT</b> LEFT TOP	1
95	A 221 885 02 16	<b>REINFORCEMENT</b> RIGHT TOP	1
100	A 221 885 01 63	<b>GUIDE</b> LEFT REAR  Plant information	1
100	A 221 885 02 63	<b>GUIDE</b> RIGHT REAR  Plant information	1
110	A 000 990 54 92 9051	<b>RIVET</b> GUIDE TO PANELLING; 6 MM  Plant information	8
130	A 001 990 24 92	<b>EXPANSION RIVET</b> REINFORCEMENT TO BUMPER COVERING; 4 MM	6

Item	Part number	Designation/additional information	Qty
150	A 221 885 03 14	<b>BRACKET</b> BUMPER MOUNTING,BELOW  Code: -(M60/M63/772);  Plant information	2
155	N 000000 001452	<b>TAPPING SCREW</b> BRACKET MOUNTING; 4.8X13  Plant information	2
160	A 003 994 85 45	<b>SPRING NUT</b> BRACKET MOUNTING; 4.8/0.5-2.5 MM	2
290	A 221 540 75 05	<b>WIRING HARNESS</b> IN REAR BUMPER  Code: 229;	1
300	A 002 540 91 17	<b>DISTANCE RADAR</b> CITY ASSIST SYSTEM (CAS)  Code: 229/230/234;  Plant information	2
310	A 000 990 54 92 9051	<b>RIVET</b> SENSOR TO BRACKET; 6 MM  Code: 229;	4
340	A 221 885 11 67	<b>HOUSING</b> INSIDE LEFT  Code: 229/230/234/237;	1
340	A 221 885 10 67	<b>HOUSING</b> INSIDE RIGHT  Code: 229/230/234/237;	1
400	A 201 990 02 40	<b>SEALING WASHER</b> MOUNTING BUMPER	2
410	A 414 990 00 51	<b>NUT</b> MOUNTING BUMPER; M6	2
450	N 910143 006001	<b>HEXALOBULAR BOLT</b> BUMPER ATTACHMENT,LATERAL; M6X16	2
460	A 001 990 46 36	<b>SCREW</b> BUMPER ATTACHMENT,LATERAL; 6X18	4
600	A 221 490 15 27	<b>TAIL PIPE TRIM</b> LEFT Replaced by: A 221 490 39 27  Code: M275+-772;  Plant information	1

Item	Part number	Designation/additional information	Qty
600	A 221 490 39 27	<b>TAIL PIPE TRIM</b> LEFT Replaces: A2214901527  Code: M275+-772;	1
600	A 221 490 16 27	<b>TAIL PIPE TRIM</b> RIGHT Replaced by: A 221 490 40 27  Code: M275+-772;  Plant information	1
600	A 221 490 40 27	<b>TAIL PIPE TRIM</b> RIGHT Replaces: A2214901627  Code: M275+-772;	1
608	A 001 984 17 29	<b>SCREW</b> TAIL PIPE	4
610	A 001 990 11 56	<b>CLIP NUT</b> EXHAUST SCREEN  Code: -772;	4
620	A 000 990 34 92	<b>EXPANSION RIVET</b> AT ANGLE; 5 MM	4
901	A 008 545 63 26	<b>CONTACT SOCKET</b> SENSOR A86/2; 0.5-0.75 MM2 MQS  Code: 229;	NB
901	A 000 545 69 80	<b>SEAL</b> SENSOR A86/2; 1.4-1.9 MM MQS/MCP1.2  Code: 229;	NB
905	A 038 545 12 28	<b>CLUTCH, MECHANICAL</b> REAR BUMPER CONNECTOR X172/2; 4-PIN MQS  Code: 229/230/234;	1
906	A 016 545 41 26	<b>CONTACT SOCKET</b> REAR BUMPER CONNECTOR X172/2; 0.25-0.5 MM2 MQS  Code: 229/230/234;	NB