

MODEL 221.0 /1, 216

- 1 Screwdriving
- 2 Steering column switch module
- 3 Locking pin

A45 Fanfare horns and airbag clock spring contact

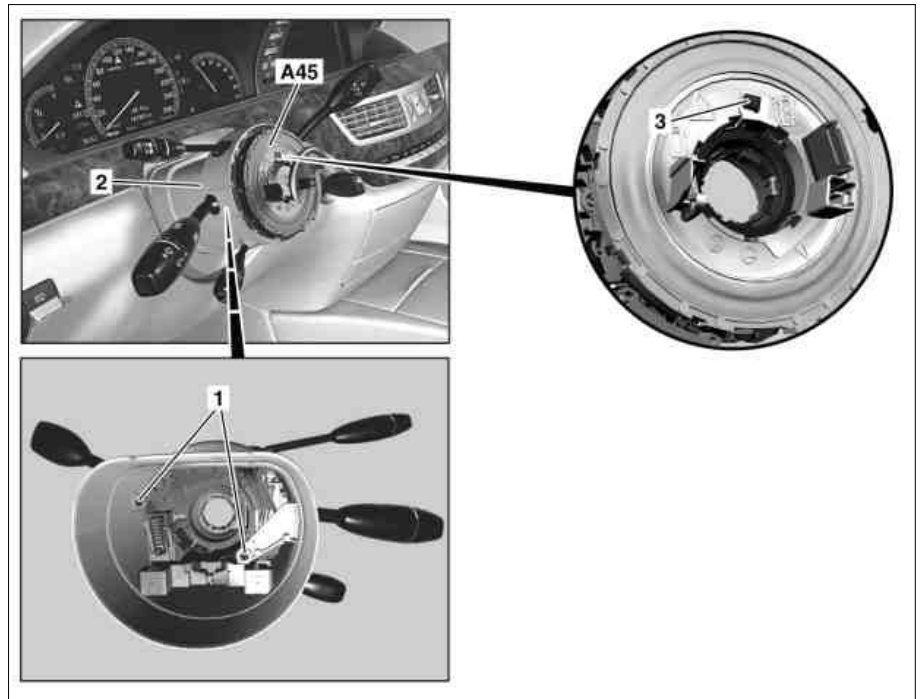

P46.10-2715-06

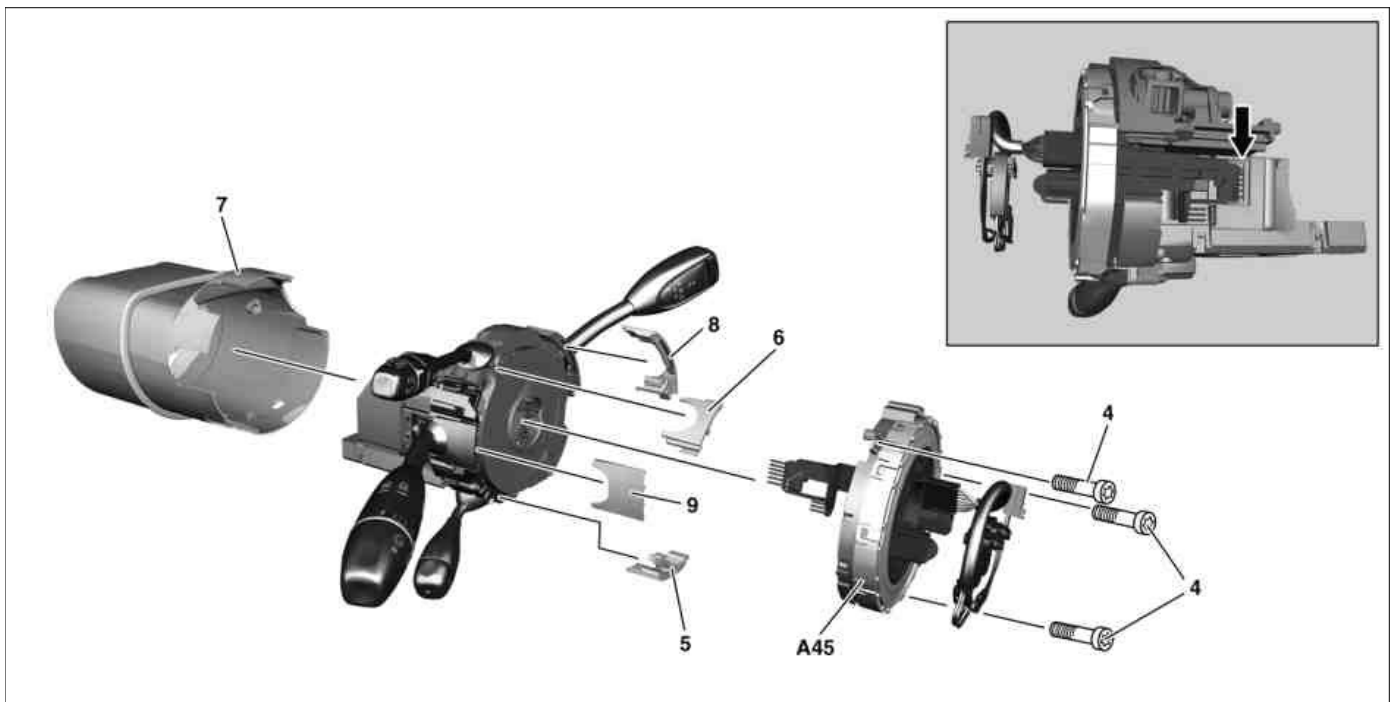

P46.10-2720-09

- 4 Screwdriving
- 5 Cover
- 6 Cover

- 7 Trim
- 8 Cover
- 9 Cover

A45 Fanfare horns and airbag clock spring contact

Modification notes

14.2.07	Information "Replace clock spring contact" replaced by information "Move clock spring contact into center position"	Step 7	
---------	---	--------	--

	Remove/install		
1	Remove steering wheel		AR46.10-P-0100SX
2	Remove jacket tube switch module (2)	Installation: Slide steering column switch module (2) complete with clock spring contact (A45) onto jacket tube and screw in mounting bolt.	AR54.25-P-2800-01SX

3	Unscrew bolts (1) from steering column switch module (2)	i Do not operate locking pin (3) as this is the anti-twist lock of the clock spring contact (A45).	
4	Remove covers (5, 6) from steering column switch module (2)		
5	Remove trim (7) from steering column switch module (2)	i Installation: Pay attention to correct seating of coverings (5, 6).	
6	Unscrew bolts (4) from steering column switch module (2)		
7	Remove clock spring contact (A45)	i Installation: If the clock spring contact (A45) was twisted, bring the clock spring contact (A45) into the center position before reinstalling: ↓ Turn clock spring contact (A45) clockwise up to the limit stop (turn gently against the limit stop, risk of damage), then turn counterclockwise until the arrows are opposite one another and the cable loop with black spots is visible in the window. i Installation: Check plug contact is correctly seated on steering angle sensor (see arrow in picture 2).	
	Checking		
8	Check the spiral contact coil (A45) for damage	i Visual inspection, if necessary replace clock spring contact (A45).	
9	Install in the reverse order		