

Transmission

722.9 in model 222

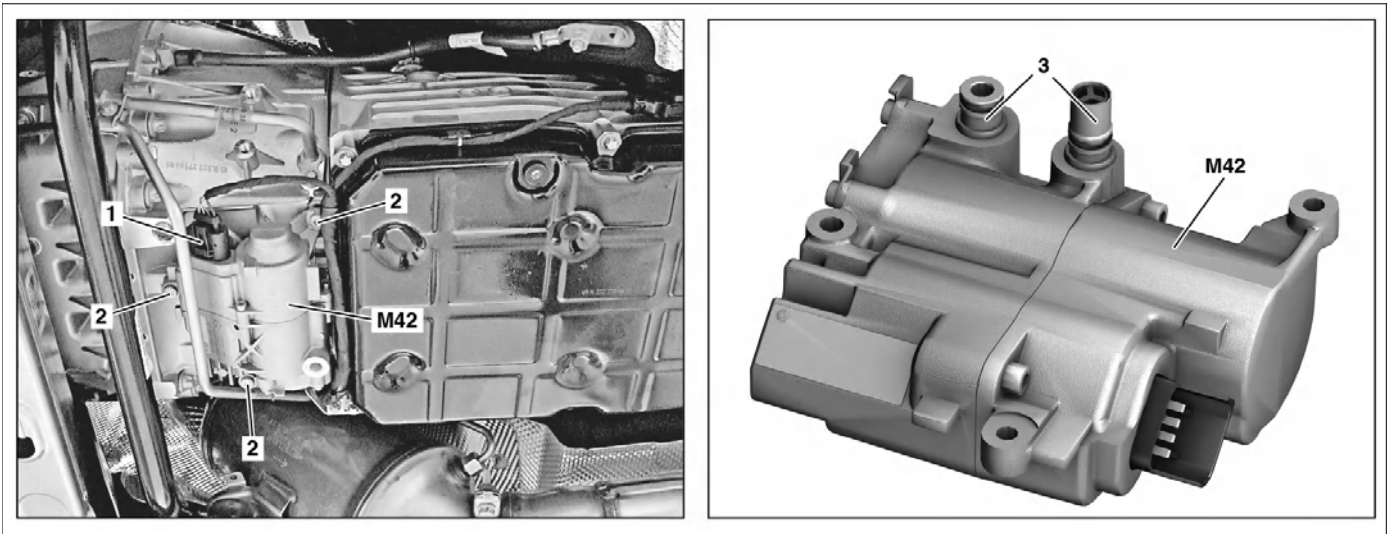

P27.57-2038-08

Shown on model 222.032

- | | | | |
|---|----------------------|-----|-----------------------------|
| 1 | Electrical connector | 3 | Fitting |
| 2 | Bolts | M42 | Electric auxiliary oil pump |

	Notes on automatic transmission		AR27.19-P-0001-01NKB
	Remove/install		
1	Remove bottom engine compartment paneling		AR61.20-P-1105LF
2	Remove drain screw from oil pan	Do not pry off overflow pipe from the base of the oil pan.	
3	Release and disconnect electrical connection (1) from electric transmission oil pump (M42)		
4	Remove screws/bolts (2) and detach electric auxiliary oil pump (M42)	Bolt, transmission auxiliary oil pump to transmission housing	*BA27.55-P-1009-01D
5	Pry out left and right fitting (3) from electric auxiliary oil pump (M42)	Installation: Check fitting (3) with sealing ring for intake and thrust side for damage, and replace, if necessary. Do not insert fitting (3) into transmission, but into electric auxiliary oil pump (M42) instead.	
6	Install in the reverse order		
7	Fill transmission with transmission fluid	Transmission 722.96 in model 222 Transmission 722.9 (except 722.96) in model 222	AR27.00-P-0270SYZ AR27.00-P-0270W
	Check		
Danger!	Risk of accident from vehicle starting off by itself when engine running. Risk of injury (bruises and burns) resulting from working on the engine while it is being started or when it is running.	Secure vehicle to prevent it from starting off by itself. Wear closed and snug-fitting work clothes. Do not touch hot or rotating parts.	AS00.00-Z-0005-01A
8	Perform engine test run and check transmission for proper function and leaktightness.		

Oil cooling

Number	Designation	Transmission 722.9
BA27.55-P-1009-01D	Bolt, transmission auxiliary oil pump to transmission housing	Nm 8