

Service Campaign Bulletin



Mercedes-Benz

Campaign No. 2014090003, October 2014

TO: ALL MERCEDES-BENZ CENTERS

SUBJECT: **Models 222, 217 (S-Class and S-Coupe), Model Years 2014 - 2015**
Replace Front and Rear Brake Pads

This Service Campaign has been initiated because Daimler AG (DAG), the manufacturer of Mercedes-Benz vehicles, has determined that the front and rear brake pads do not meet current specifications and may cause braking noise at low outside temperatures. To correct this condition an authorized Mercedes-Benz dealer will replace the front and rear brake pads at the next dealer visit.

Prior to performing this Service Campaign:

- Please check VMI to determine if the vehicle is involved in the Campaign and if it has been previously repaired.
- Please review the entire Service Campaign bulletin and follow the repair procedure exactly as described.

Approximately 9,833 vehicles are affected.

Order No. P-SC 2014090003

This bulletin has been created and maintained in accordance with MBUSA-SLP S423QH001, Document and Data Control, and MBUSA-SLP S424HH001, Control of Quality Records.

Service Campaign Bulletin

Service Campaign Bulletin

Service Campaign Bulletin

Service Campaign Bulletin

Service Campaign Bulletin

Procedure

1.  Replace front axle brake pads, refer to: WIS: AR42.10-P-1600LF.

i **Note:** (Regarding above WIS instructions)

Replace front pull rod bolt (refer to step 6 in above WIS instructions) with new bolt part no. N 910 105 008 008.

IMPORTANT! Loctite® 243 thread locking compound **must** be applied to the threads of the new bolt (N 910 105 008 008) prior to installation. The new bolt (N 910 105 008 008) is not provided with thread locking compound applied to the threads.

2.  Replace rear axle brake pads, refer to: WIS: AR42.10-P-1700LF.

i **Note** (regarding WIS documents referenced in this Procedure):

Replacement of parts not listed in the parts table of this Procedure are not claimable under this campaign. If replacement of additional part(s) is necessary, check coverage prior to submitting under warranty.

Special Tools

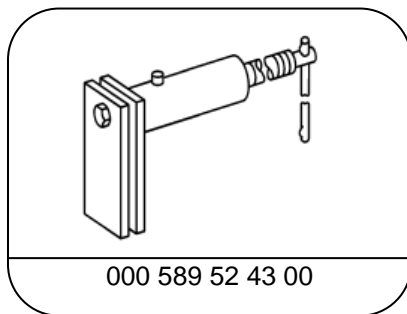

Resetting device

Primary Parts Information

Qty.	Part Name	Part Number	Estimated Replacement Rate
1 set	Front axle brake pad parts kit	A 008 420 02 20 05	100%
2	Bolt (front pull rod)	N 910 105 008 008	
1 set	Rear axle brake pad parts kit	A 008 420 08 20 05	
1	Thread locking compound (Loctite 243; 10ml) ¹⁾	A 613 989 09 71 09	

¹⁾ 1 container is sufficient for 30 vehicles. Submit as local purchase TLC00037qty of 1, handling is included.

i **Note:**

- Please be aware that only the part number(s) referenced in the Campaign Bulletin is/are approved for use to repair the vehicle. Repairs performed using any other part(s) will not have been performed in accordance with the campaign. Accordingly, warranty claims submitted with reference to an improper part number(s) will be denied.
- The following allowable labor operation should be used when submitting a warranty claim for this repair:

Warranty Information

Operation: Replace (all) brake pads (02-8624).

Damage Code	Operation Number	Labor Time (hrs.)
42 902 31 7	02-8624	1.8