

# Mercedes-Benz S-Class Coupe



C217

Model Year 2020

**Preliminary – Subject to Change**

Mercedes-Benz  
The best or nothing.





## Important note

The information presented in this guide is based on the most current information available and is intended for internal use only. Mercedes-Benz reserves the right to make changes at any time, without notice, to colors, materials, equipment, special specifications and models.

Pricing may not yet be finalized for some models or options.

Due to variances among monitors and printers the colors that appear on your screen and printouts may not be exact.

For illustrative purposes, some images may show vehicles with European Specification.

## Revision History

<i>Date</i>	<i>Changes</i>
02/25/2019	Publish DOG
04/01/2019	Update: Deletion of paint 831 Graphite Grey Addition of paint 183 Magnetite Black



## *S 560 4MATIC*

---



Models



What's new



Standard Equipment



Exterior Paint Colors



Wheels



Interior Upholstery



Interior Trims



Option Packages



Stand-Alone Options



Options in Detail

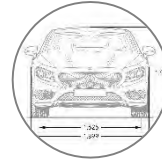

Specifications



## *S 560 4MATIC* (S560C4 - 217.386)

- MSRP \$TBA
- 4.0L V8 Biturbo Engine
- 463 Horsepower
- 516 lb-ft of Torque
- Launch date: Summer 2019





## *Standard Equipment*

### **Premium Package**

- 432 – Active Multicontour Front Seats with Massage Feature
- 501 – Surround View System
- 902 – Front Variable Heated Seats PLUS





## *Steering Wheel*



### **3-spoke Nappa Leather Multifunction Sports Steering Wheel (L2B)**

- Newly redesigned with Touch Control Buttons to control the entire multimedia system
- Active Distance Assist DISTRONIC or standard cruise control is controlled via steering wheel-mounted controls
- Leather and Leather & Wood Steering Wheels with 3-spoke design available

## Ambient lighting with 64 colors and 3 color zones



### Ambient lighting with 64 colors and 3 color zones (891)

- The ambient lighting in 64 colors gives the light a uniquely diverse style and showcases the interior like a work of art
- Three different zones from bottom to top: footwell (zone 1), trim level (zone 2) and Widescreen Cockpit (zone 3)
- Every display style of the Widescreen Cockpit is oriented towards a matching color scheme: "Glacier Blue" for Classic, "Red Moon" for Sport, "Down Blue" for Progressive
- Eight color schemes consist of two colors respectively –the Widescreen Cockpit and the footwell are in the same color, and the trim level forms a contrast. In "dynamic mode", this color distribution changes
- Two additional color schemes each contain five colors – which slowly interchange ("dynamic mode") and thus ensure that the color constantly changes
- Special emotively appealing effects: A Coming Home visualization welcomes the driver, and the climate control indicates in color via the ambient lighting whether a warmer or colder temperature is being set
- Just as variably adjustable is the brightness of the LEDs, with five levels and four zones: Widescreen Cockpit, area of the front seats, rear plus complete dimming zone
- The ambient lighting is incorporated in the ENERGIZING comfort control programs



## *Driver Assistance Systems*

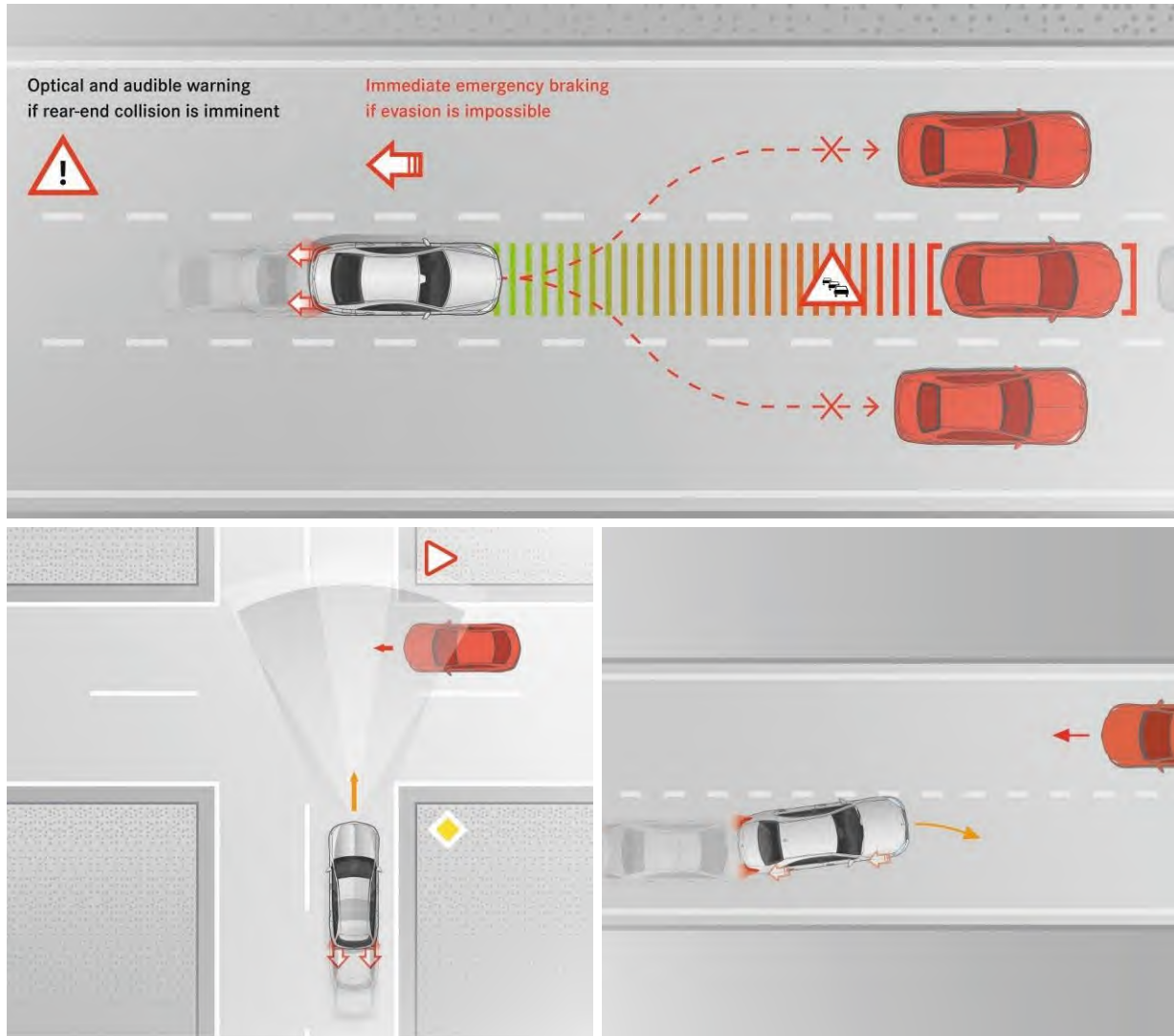

### Driver Assistance Package (997)

- **Active Distance Assist DISTRONIC®** is able to follow a vehicle in front at a pre-selected distance at wider range of speeds
- **Active Steering Assist** functions at a wider range of speeds and can now actively intervene even if road lines are unclear or non-existent at certain speeds; can now function in curves with a tighter radius
- **Active Emergency Stop Assist** brakes the vehicle to a standstill in its lane if it detects that the driver is no longer actively driving the vehicle while it is on the move with Active Distance Assist DISTRONIC and Active Steering Assist engaged. Can now unlock the doors when the vehicle is stationary to allow first aid responders immediate access to the vehicle's interior. With available mbrace® Secure, the system simultaneously makes an emergency call
- **Active Lane Change Assist** is a radar-and-camera-based system that aids the driver when changing lanes. When a turn is indicated, this feature will aid with steering into the adjacent lane if it detects the lane is empty
- **Active Speed Limit Assist** can adapt vehicle speed to identified speed limits and can now adjust preemptively when speed limits are going to change
- **Route-Based Speed Adaptation** the vehicle is now able to reduce the speed in anticipatory mode by referencing the COMAND map data ahead of bends, junctions, roundabouts, toll booths and exit roads.
- **Active Brake Assist with Cross-Traffic Function**
- **Evasive Steering Assist** this system assists by adding calculated steering torque to aid in steering wheel movement when a driver deliberately or instinctively performs an evasive maneuver around a pedestrian
- **Active Blind Spot Assist** is active at a wider range of speeds and informs the driver to help avoid an imminent side impact by single-sided braking
- **Active Lane Keeping Assist** is active now at a wider range of speeds





## ***ENERGIZING Comfort Control***



### **ENERGIZING Comfort Control**

- ENERGIZING Comfort is a world-first entering series production to enhance the physical comfort and performance both while driving and during breaks
- It systematically uses the functions of the climate control system (including fragrancing) and the seats (heater, ventilation, massage), the console heating as well as lighting and musical atmospheres, and enables a specific wellness set-up tailored to the mood and need of the driver
- The following six Energizing Comfort programs can be selected: Freshness, Warmth, Vitality, Joy, Comfort, Training (three trainings – muscle relaxation, muscle activation and balance – each with several exercises)
- Each program runs for ten minutes and are visualized on the headunit with color graphics, and backed by suitable music
- Five songs are already stored in the program and if personal music selections are available, for example via the Media Interface, the system analyzes them in the background and assigns them to a program based on the beats per minute (bpm)
- ENERGIZING Comfort also incorporates ambient lighting, which is harmoniously tailored to each of the individual screen designs



## Updated body style with previous AMG-Line front bumper as standard



European picture shown – wheels n/a in US





*Newly designed AMG Line*





*Wireless Charging in the Front*





## *Enhanced Voice Control*



### **Operate COMAND® and vehicle functions safely and conveniently via Voice Control** *Standard*

The voice-operated control system allows the multimedia system and now some of the vehicle functions to be operated while driving with as little distraction as possible. Activating Voice Control by pressing the button on the right of the multifunction steering wheel enables the driver to keep their hands on the steering wheel. The system is switched off via the back button on the steering wheel or pressing the same Voice Control button.

#### **Typical commands for the system include:**

- "Navigate to address, POI, contact" - this universal command enables input of all types of destinations and initiates a search through the address book contacts, the navigation database and also on the internet for Points Of Interest
- "Call name (or) number" - this command allows an address book contact as well as a phone number to be called
- "Station name" - this command allows an available station name to be selected when the radio is switched on

#### **But now, in-vehicle functions can be controlled as well. For example:**

- "Turn seat heating on"
- "Change ambient light to blue"
- "Set climate control to 68 degrees"

Vehicle functions can also be controlled with commands such as "Show me the climate control settings menu" or "Start massage". Voice Control can also be used for controlling Mercedes-Benz Apps. For example with commands such as "Find a nearby restaurant" in the POI search.



## *Performance & Handling*

- 4.0L V8 biturbo engine
- 9G-TRONIC 9-speed automatic transmission
- ECO Start/Stop System
- AIRMATIC Air Suspension

## *Comfort & Convenience*

- Air Balance Package
- 64-color Ambient Lighting
- Burmester® Premium Surround Sound System
- COMAND System NTG 5.5
- Smartphone Integration
- Front heated seats
- Power-folding mirrors
- Soft-Close Doors
- Illuminated Door Sills
- Nappa Leather Upholstery
- Panorama Roof
- Heated and Ventilated Power Front Seats with Memory
- Active Multicontour Front Seats with Massage Feature
- Wireless Charging front
- KEYLESS-GO with HANDS-FREE-ACCESS
- ENERGIZING Comfort control
- Electronic trunk closing
- Voice control system

## *Safety & Security*

- LED Intelligent Light System
- Auto-dimming Mirrors
- Active Brake Assist
- ATTENTION ASSIST
- Active Parking Assist & Electronic Trunk Closer
- Advanced Airbag Protection System
- MAGIC VISION CONTROL
- Surround View System
- Lane Tracking Package (Blind Spot Assist and Lane Keeping Assist)



## Non-metallic Paints



**040**  
Black  
*Option price: \$0*

## Metallic Paints & Magno Paints



**183**  
Magnetite Black  
*Option price: \$0*



**197**  
Obsidian Black  
*Option price: \$0*



**775**  
Iridium Silver  
*Option price: \$0*



**890**  
Lunar Blue  
*Option price: \$0*



**988**  
Diamond Silver  
*Option price: \$0*



**998**  
Anthracite Blue  
*Option price: \$0*



**989**  
Emerald Green  
*Option price: \$0*



**992**  
Selenite Grey  
*Option price: \$0*

## *designo*<sup>®</sup> Paints



**799**  
Diamond White  
*Option price: \$795*



**049**  
Cashmere White Magno  
*Option price: \$3,950*



**11R**  
19" Multi-Spoke Wheels  
R02, R66  
Standard



**R17**  
19" Twin-5-Spoke Wheels  
R02, R66  
No charge



**13R**  
20" Multi-Spoke Wheels  
R01, R66  
\$1,270



**54R**  
20" Multi-Spoke Wheels  
R01, R66  
\$3,250



**793**  
19" Twin 5-Spoke Wheels  
R02, R66  
Only with AMG Line Exterior (321)



**RRM**  
20" Twin-5-Spoke Wheels  
R01, R66  
Only with AMG Line (321)  
\$750







<i>Code</i>	<i>Wheel Size</i>	<i>Description</i>	<i>Wheel Dimensions</i>	<i>Mobility</i>	<i>Availability</i>	<i>MSRP</i>
11R	19"	Multi-Spoke Wheels	245/45 R 19 on 8.5 J x 19 ET36 (Front) 275/40 R 19 on 9.5 J x 19 ET43.5 (Rear)	R02, R66	S 560 4MATIC	Std.
R17	19"	Twin 5-Spoke Wheels	245/45 R 19 on 8.5J x 19 ET36 (Front) 275/40 R 19 on 9.5J x 19 ET43.5 (Rear)	R02, R66	S 560 4MATIC	\$ 0
793	19"	Twin 5-Spoke Wheels	245/45 R 19 on 8.5 J x 19 ET38 (Front) 275/40 R 19 on 9.5 J x 19 ET38 (Rear)	R02, R66	S 560 4MATIC	\$ 0 <i>Requires AMG Line (321)</i>
13R	20"	Multi-Spoke Wheels	245/40 R 20 on 8.5J x 20 ET 36 (Front) 275/35 R 20 on 9.5 J x 20 ET43.5 (Rear)	R01, R66	S 560 4MATIC	\$1,270
54R	20"	Multi-Spoke Wheels	245/40 R 20 on 8.5 J x 20 ET 36.5 (Front) 275/35 R 20 on 9.5 J x 20 ET 44 (Rear)	R01, R66	S 560 4MATIC	\$3,250
RRM	20"	AMG Multi-Spoke Wheels	245/40 R 20 on 8.5 J x 20 ET38 (Front) 275/35 R 20 on 9.5 J x 20 ET38 (Rear)	R01, R66	S 560 4MATIC	\$750 <i>Requires AMG Line (321)</i>



**801**

Black

*Standard*

*Requires 51U Black Headliner*



**805**

Porcelain & Espresso Brown

*Standard*

*Requires 55U Porcelain Headliner*



# Interior Upholstery – *designo* Exclusive Nappa Leather



**961**  
Black

Option price: \$3,250

Requires 61U or 68U Headliner, Requires P34



**965**

Porcelain & Espresso Brown

Option price: \$3,250

Requires 65U Headliner, Requires P34



**978**

Crystal Grey & Black

Option price: \$3,250

Requires 61U or 68U Headliner, Requires P34



**974**

Saddle Brown & Black

Option price: \$3,250

Requires 61U Headliner, Requires P34



**975**

Porcelain & Deep Sea Blue

Option price: \$3,250

Requires 65U Headliner, Requires P34



**977**

Bengal Red & Black

Option price: \$3,250

Requires 61U Headliner, Requires P34

# Interior Upholstery – *designo* Exclusive Nappa Leather



**985**

Porcelain & Titian Red

*Option price: \$3,250*

*Requires 65U Headliner, Requires P34*





<i>Code</i>	<i>Upholstery</i>	<i>Seats</i>	<i>Floor Mats</i>	<i>Upper Dash/Lower Dash</i>	<i>Seat Belts</i>	<i>Steering Wheel</i>	<i>Headliner</i>
801	Black	Black	Black	Black	Black	Black	Black
805	Porcelain & Espresso Brown	Porcelain	Porcelain	Espresso Brown/Porcelain	Porcelain	Porcelain	Porcelain
961	Black	Black	Black	Black/Black	Black	Black	Black or Crystal Grey
965	Porcelain & Espresso Brown	Porcelain	Porcelain	Espresso Brown/Porcelain	Porcelain	Porcelain	Porcelain
978	Crystal Grey & Black	Crystal Grey	Black	Black/Crystal Grey	Black	Black	Crystal Grey or Black
974	Saddle Brown & Black	Saddle Brown	Black	Black/Saddle Brown	Black	Black	Black
975	Porcelain & Deep Sea Blue	Porcelain	Deep Sea Blue	Deep Sea Blue/Porcelain	Porcelain	Porcelain	Porcelain
977	Bengal Red & Black	Bengal Red	Black	Black/Bengal Red	Black	Black	Black
985	Porcelain & Titian Red	Porcelain	Porcelain	Titian Red/Porcelain	Porcelain	Porcelain	Porcelain



**729**

Black High-gloss Poplar Wood  
*Option Price: No charge*



**H29**

Burl Walnut Wood  
*Option Price: No charge*

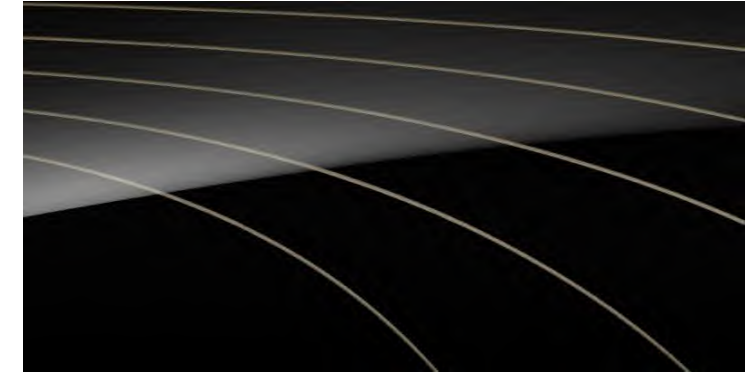

**H16**

*designo* Black Piano Lacquer Flowing Lines  
*Option Price: \$1,300*

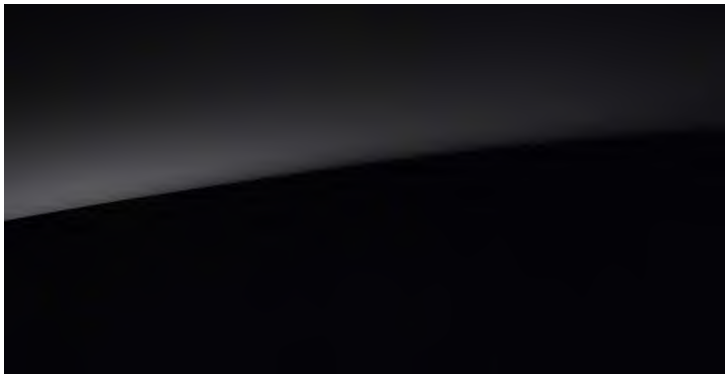

**H21**

*designo* Black Piano Lacquer  
*Option Price: \$800*

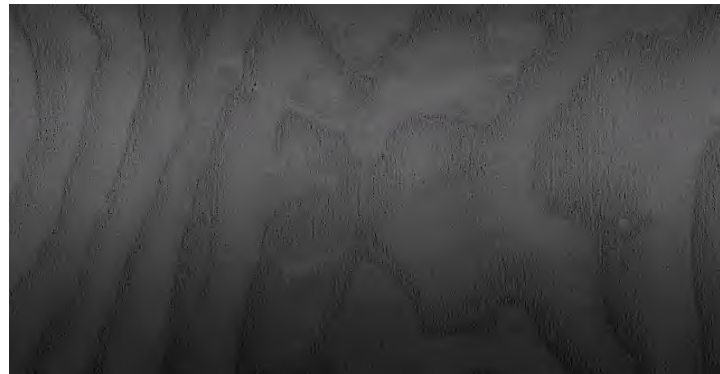

**H30**

Grey Satin-Finish Ash Wood  
*Option Price: \$800*  
*n/a with DB0 and 443*

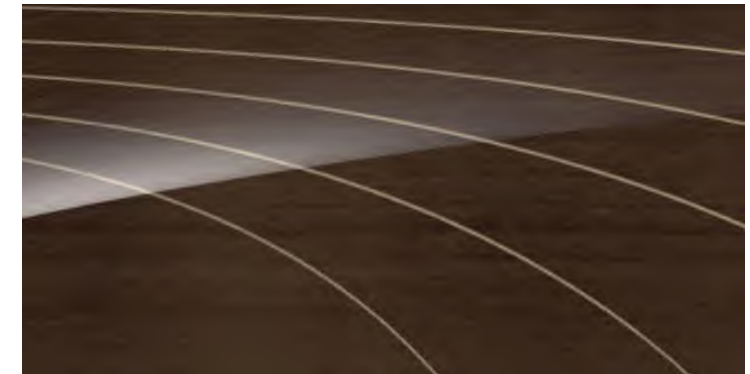

**H26**

*designo* Magnolia Flowing Lines  
*Option Price: \$1,300*  
*n/a with DB0 and 443*





<i>Code</i>	<i>Packages</i>	<i>Availability</i>	<i>MSRP</i>
DP1	<b>Premium Package</b> <ul style="list-style-type: none"> <li>▪ 432 – Multicontour Front Seats with Massage Feature</li> <li>▪ 463 – Head-Up Display</li> <li>▪ 501 – Surround View System</li> <li>▪ 902 – Front Variable Heated Seats Plus</li> </ul>	All Models	Standard
DB0	<b>Warmth and Comfort Package</b> <i>Not available with H30 or H26 designo Trims</i> <ul style="list-style-type: none"> <li>▪ 872 – Heated Rear Seats</li> <li>▪ 443 – Heated Steering Wheel</li> <li>▪ 314 – Wood/Leather Steering Wheel</li> <li>▪ P68 – Heated Front Door and Center Console Armrests</li> </ul>	All Models	\$ 1,990
DG1	<b>AMG Line Exterior</b> <ul style="list-style-type: none"> <li>▪ 772 – AMG Line Exterior</li> <li>▪ 951 – Sport Package Code</li> <li>▪ Wheel Choice of:                             <ul style="list-style-type: none"> <li>▪ 793 – 19” AMG Twin 5-Spoke Wheels</li> <li>▪ RRM – 20” AMG Multispoke Wheels (+\$750)</li> </ul> </li> </ul>	All Models	\$ 5,900
DA2	<b>Driver Assistance Package</b> <ul style="list-style-type: none"> <li>▪ 23P – Driver Assistance Package</li> <li>▪ K32 – Active Lane Change Assist</li> <li>▪ K33 – Extended Restart in Stop-and-Go Traffic</li> <li>▪ K34 – Route-Based Speed Adaptation</li> <li>▪ 233 – Active Distance Assist DISTRONIC</li> <li>▪ 266 – Active Steering Assist</li> <li>▪ 513 – Active Speed Limit Assist</li> <li>▪ 546 – Automatic Speed Takeover</li> </ul>	All Models	\$ 2,250

# Stand-Alone Options



<i>Code</i>	<i>Options</i>	<i>Availability</i>	<i>MSRP</i>
811	<b>Burmester® High-End 3D Surround Sound System</b>	All Models	\$ 6,400
610	<b>Night View Assist PLUS</b>	All Models	\$ 2,260
398	<b>MAGIC SKY CONTROL</b>	All Models	\$ 2,500
5U5	<b>Swarovski Crystal Headlamps</b> <i>Requires Night View Assist (610)</i>	All Models	\$ 1,750
308	<b>Refrigerator in Rear Center Compartment</b> <i>Reduces Trunk Space, removable</i>	All Models	\$ 1,100
443	<b>Heated Steering Wheel</b> <i>n/a with H26, H30 Trims, Included in Warmth and Comfort Package (DB0)</i>	All Models	\$ 250
597	<b>Heated Windshield</b> <i>Requires Head-Up Display (463)</i>	All Models	\$ 550
P34	<b>Exclusive Upholstery Control Code</b> <i>Select when ordering <b>designo</b> upholstery</i>	All Models	\$ N/A
463 	<b>Head Up Display</b>	All Models	\$ 990

<i>Code</i>	<i>VPC Installed Accessories</i>	<i>Availability</i>	<i>MSRP</i>
068	<b>Wheel Locks</b>	All Models	\$ 150





## *Steering Wheel*



**3-spoke Nappa Leather Steering Wheel (L5C)**

*Standard*

- Black
- 3-spoke design
- Perforated in the grip area
- Touch Control buttons



**3-spoke Wood & Leather Steering Wheel (L2D)**

*N/a with: H30 - Grey satin-finish ash wood trim + H26 - designo brown flowing lines magnolia wood*

*Standard with 443 Heated Steering Wheel or DB0 Warmth & Comfort Pkg*

- 3-spoke design
- Touch Control buttons





## ***Burmester® high-end 3D surround sound system***



### **Burmester® high-end 3D surround sound system (811)**

- 24 high-performance speakers including subwoofer for perfect music reproduction tailored to the vehicle interior
- 27 amplifier channels with a total system output of 1,560 watts impress with their extraordinarily clear and nuanced sound
- Frontbass technology with woofers integrated into the body shell for vibrant bass reproduction
- Active subwoofer bass box with integral 40-watt amplifier in the boot for impressive reproduction of even the lowest tones
- Active analogue filters ensure many-faceted, natural and spatial mid and treble tones for the special Burmester "feel-good sound"
- VIP seat function to optimise the sound for individual seats
- Five sound presets for an enhanced listening experience: Pure, Easy Listening, Live, Surround, 3D Surround
- 3D surround sound for a new dimension in music reproduction
- Dolby Digital 5.1/DTS for genuine surround sound



## *Panoramic Roof with MAGIC SKY CONTROL*



### **Panoramic Roof with MAGIC SKY CONTROL (398)**

- Large, single-section glass module covering 2/3 of the roof area (1.32 m<sup>2</sup>)
- Glass transparency controllable via switch in overhead control panel: change from dark to transparent and vice versa within just a few seconds
- When the glass is transparent: clear view of the sky and a particularly light, friendly atmosphere
- When the glass is dark: effective means of reducing heating of the interior
- Directly connected to the windscreen, creating a continuous glass look with a homogeneous surface
- Makes the vehicle appear even lighter
- Rear third of the roof painted in the body color

### **Technical Details**

Several films are sandwiched between the panoramic roof's two glass sheets. Between these films is an emulsion containing particles that align themselves with the electric field when an AC voltage is applied. When the voltage is switched off, the particles arrange themselves randomly and prevent most of the light from passing through. The glass remains dark. When an AC voltage of 120V is applied, the particles align themselves in the electrical field and allow the light to pass through the glass. The glass becomes transparent.



## *New Rim Options*



**20" Multispoke Wheels (13R)**  
R01, R66



**20" Multispoke Wheels (54R)**  
R01, R66



**20" AMG Multi-Spoke Wheels (RRM)**  
R01, R66





## *designo Bengal Red & Black Exclusive Nappa Leather*





## *designo Porcelain & Titian Red Exclusive Nappa Leather*



## *New Trim Options*



**Grey Satin-Finish Ash Wood (H30)**



**Brown High-gloss Burl Walnut Wood (H29)**



***designo* Magnolia Flowing Lines (H26)**



	<i><b>S 560 4MATIC</b></i>
Engine Configuration	4.0L V8 biturbo engine
Power (hp)	463
Torque (lb-ft)	516
Displacement (cc)	3.982
Acceleration 0-60 mph (sec)	4.5
Fuel Economy (Cty/Hwy/Comb)	tba
Top Speed (mph)	130
Fuel Requirement (Octane)	tba
Compression	10.5 : 1
Transmission	9G-TRONIC 9-Speed Automatic Transmission
Transmission Speeds	9
Drive Configuration	All-wheel Drive
Fuel Tank Size (gallons)	tba
Trunk Size (cubic feet)	tba
Curb Weight (lbs)	tba
Maximum Load (lbs)	tba
Vehicle Length (in.)	198.11
Vehicle Width w/ exterior mirrors (in.)	82.99
Vehicle Height (in.)	55.55
Wheelbase (in.)	115.94
Track Width Front/Rear (in.)	63.98/64.92
Towing Capacity (lbs)	tba



# Specifications – S 560 4MATIC

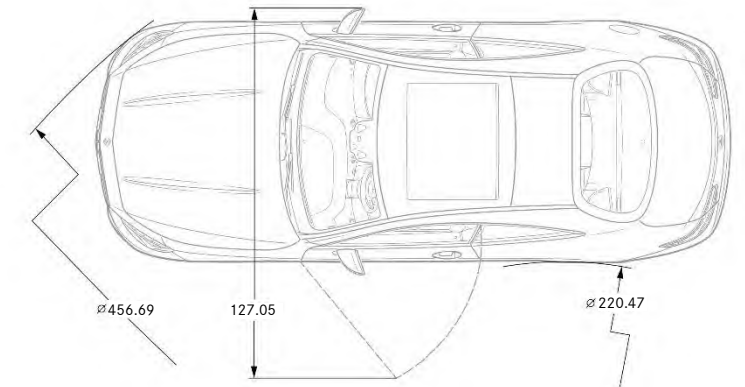
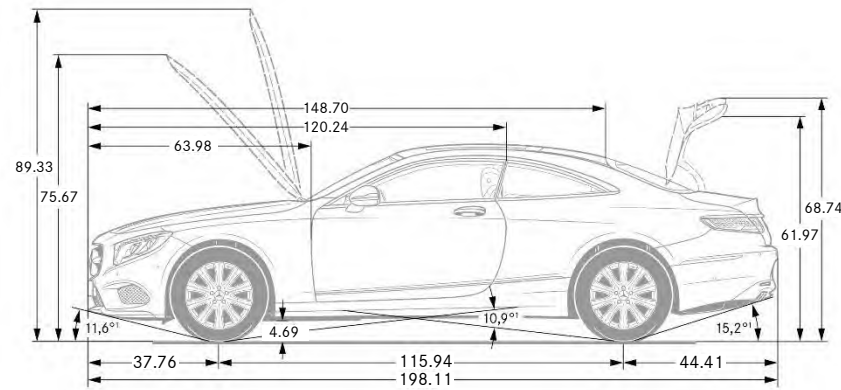
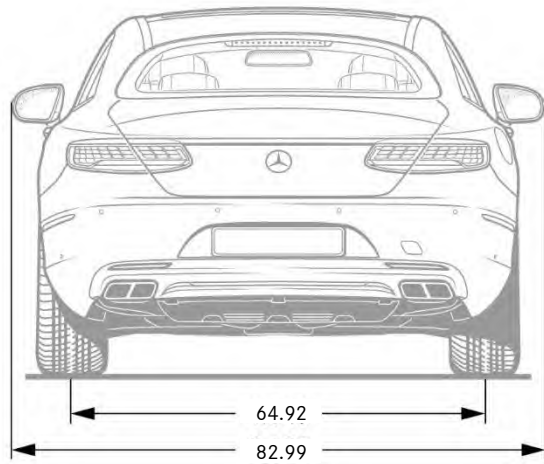
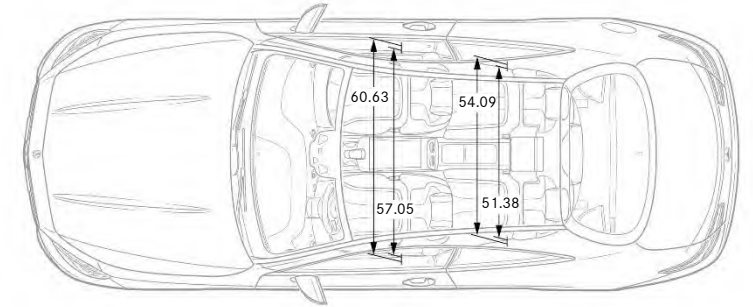
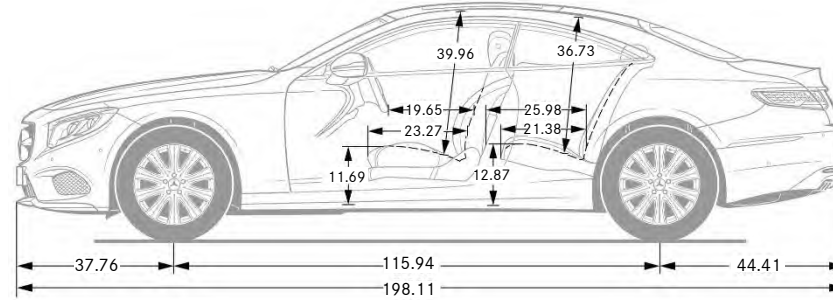
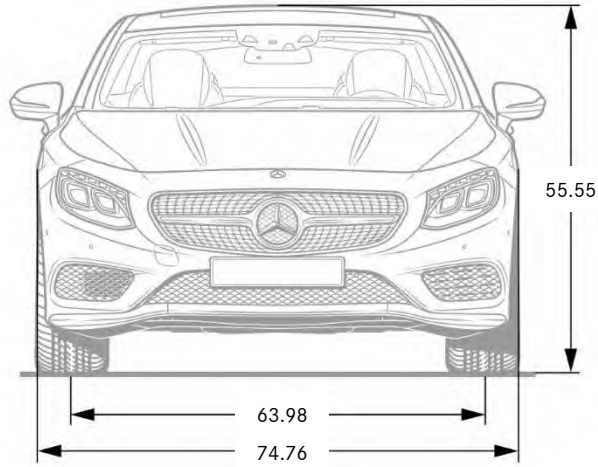

# Mercedes-AMG S-Class Coupe



C217

Model Year 2020

Preliminary – Subject to Change

**AMG**  
DRIVING PERFORMANCE

## *S 63 & S 65*

---



Models



Interior Trims



What's new



Option Packages



Standard Equipment



Stand-Alone Options



Exterior Paint Colors



Options in Detail



Wheels



Specifications



Interior Upholstery



## *S 63 (217.388)*

- MSRP \$TBA
- Handcrafted Mercedes-AMG 4.0L V8 biturbo Engine
- Horsepower 603 hp
- Torque 664 lb-ft
- 3.4 sec (0-60 mph)
- Launch date: Summer 2019

## *New Optional Equipment*

- Introduction of U88 AMG Drive Unit Steering Wheel Buttons
- Introduction of DC3 AMG Aerodynamics Package

*Mercedes-AMG S 63 - Exterior Design*

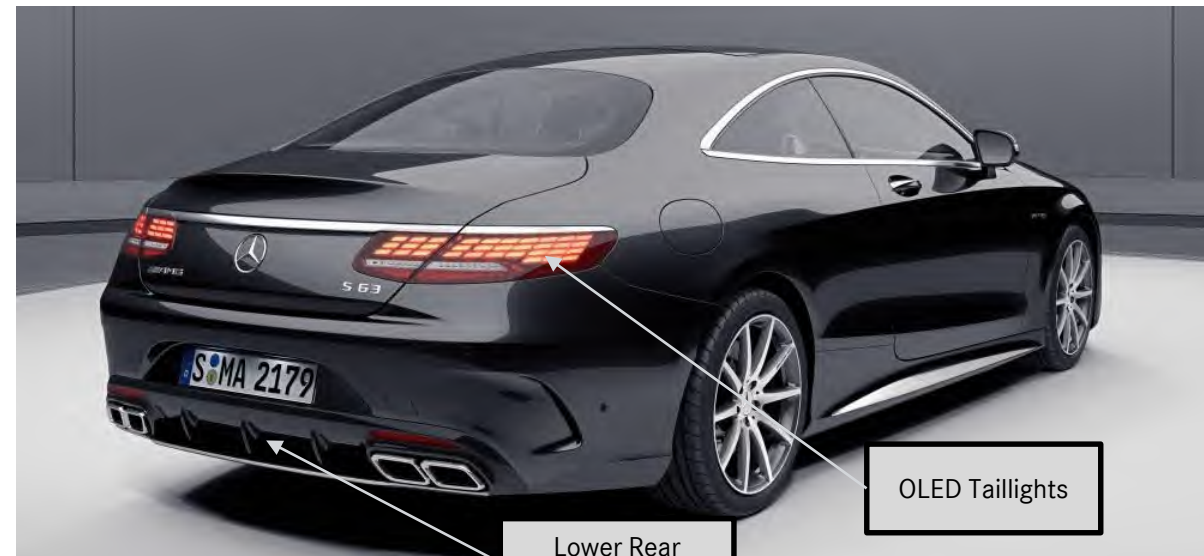

## Handcrafted AMG 4.0L V8 biturbo engine (M177 E40DEH LA AMG)



### Handcrafted AMG 4.0L V8 Biturbo engine (M177 E40DEH LA AMG)

Standard on S63

- **Aluminum crankcase** featuring a racing inspired closed-deck design
  - The area around the cylinders' coolant enclosure is closed off at the top and is only perforated by cooling channels
  - This makes the engine block more rigid and able to withstand greater loads
- **Forged, lightweight aluminum pistons** – high performance and low weight
- **Two Twin-scroll turbochargers** with separate exhaust channels
  - Positioned between the cylinder heads for faster response
  - Inspired by Formula 1
  - Keeps engine compact, improves turbo response and lowers emissions
  - Separate exhaust channels prevent turbos from having a negative impact on each other during load/directional changes, and enables faster spooling/buildup of turbo pressure
- **Variably Adjustable Inlet and Outlet Valves**
  - Filled with sodium
  - Light weight

## *AMG Performance 4MATIC+*



### **AMG Performance 4MATIC+**

*Standard on S63*

The performance-oriented all-wheel drive with fully variable torque distribution combines optimal traction, hallmark AMG driving dynamics, and the ultimate in driving enjoyment. It enhances driving safety and adhesion on wet or wintry road surfaces while at the same time allowing an emotional drifting experience. This is made possible by the fully variable torque distribution, offering the driver the benefits of all-wheel drive and rear-wheel drive in equal proportions.

An electronically controlled clutch provides for variable connection of the permanently-driven rear axle with the front axle. The ideal torque distribution is calculated continuously, according to the given driving situation and the driver's wishes. This enables a seamless transition from traction-oriented all-wheel drive to 100% rear-wheel drive. In addition to traction and transverse dynamics, the all-wheel drive also improves the longitudinal dynamics of the vehicle for even more dynamic acceleration.

- Combines the advantages of an all-wheel drive with those of a rear-wheel drive: optimum traction, hallmark AMG vehicle dynamics, and maximum driving pleasure
- Drift capability, as fully variable torque distribution means that 100% rear-wheel drive is possible
- Improved handling safety and road holding on wet or wintry road surfaces
- Improved longitudinal dynamics for even more aggressive acceleration
- The compact, lightweight design avoids any loss of space in the interior



## AMG SPEEDSHIFT MCT 9-Speed Transmission



### **AMG SPEEDSHIFT MCT 9-Speed Transmission**

*Standard on S63*

MCT stands for Multi-Clutch Transmission, whereby an innovative wet start-off clutch running in an oil bath replaces the conventional torque converter. Thanks to its low rotational inertia, the transmission responds instantaneously without the losses typical of a torque converter. This helps to reduce fuel consumption. A further merit of the MCT transmission is its low weight thanks to its magnesium housing.

#### **Added driving pleasure, added safety – the double-clutching function**

Ultra-fast, responsive, multiple downshifts are another forte of the AMG SPEEDSHIFT® MCT 9-speed transmission. The driver can change via kick down directly from 9th into 6th or from 5th into 2nd gear, for example. The automatic double-clutching function is active in drive programs "S", "S+", and "M". Each manual or automatic downshift is accompanied by a precisely metered blip on the throttle – with rising intensity from "S" through to "S+" and "M". This not only heightens the emotional appeal: downshifting minimizes the load cycles, which has a particularly positive effect when braking into corners and makes for improved handling safety on wet and slippery surfaces.

#### **For a perfect start – the RACE START function**

The RACE START function ensures optimal acceleration from a standing start. It can be activated when the vehicle is stationary in the AMG DYNAMIC SELECT drive programs "S" or "S+." To activate, the driver is required to hold down the brake pedal with their left foot while simultaneously flooring the accelerator pedal (kick down). The driver can then increase or lower the pulling-away engine speed as appropriate (from 2,000-4,000rpm), according to the prevailing road conditions. When the driver releases the brakes while continuing to floor the accelerator pedal, the vehicle accelerates with the best possible traction and fastest launch.

## 3-stage ESP®



### **3-stage ESP®**

*Standard on S63*

#### **The three-stage Electronic Stability Program (ESP®) at a glance:**

Three separate control strategies for safety and driving pleasure, selectable using the ESP® button or through the AMG DYNAMIC SELECT system:

- "ESP® ON": ensures a high level of safety by adapting the system in line with the vehicle's sporty characteristics
- "ESP® SPORT HANDLING MODE": Allows higher drift angles prior to system intervention for a sporty driving style
- "ESP® OFF": System switched off for sporty driving style on dedicated racetracks

#### **Added driving pleasure, combined with safety**

This system provides safety and driving pleasure in equal measure. The ESP® button allows the driver to choose between three individual control strategies: "ESP ON", "ESP SPORT HANDLING MODE" and "ESP OFF". The currently activated mode is indicated in the AMG instrument cluster. With "ESP ON", if the vehicle's road holding starts to become unstable, the brakes are applied on one or more wheels and the engine torque is reduced. "ESP® SPORT HANDLING MODE" is activated as soon as the driver gives the ESP® button a single brief press. In this mode, over/understeer control as well as engine torque control allow more dynamic road holding and therefore corresponding drift angles. "ESP® OFF" is activated when the driver gives the ESP® button a long press. In this mode, in the interests of driving dynamics, the engine torque is no longer reduced. "ESP® OFF" should be used only by experienced drivers on dedicated racetracks.

#### **ESP® Curve Dynamic Assist – more safety in bends**

When the ESP sensors register a tendency to understeer on bends, this can be reduced by specific braking intervention at the inside wheels. This intervention leads to a slight yawing motion around the vehicle's vertical axis, counteracting the understeer. At the same time drive torque is increased slightly to the outside wheel to compensate and steer through the bend with precision.

## *Performance & Handling*

- 3-stage ESP® with Curve Dynamic Assist
- AMG High-Performance Compound Braking System
- New-generation AMG Performance Steering Wheel with Shift Paddles
- AMG Adaptive Sport Suspension
- AMG-exclusive Sport Instrument Cluster Design
- AMG-specific multilink suspension geometry
- AMG DYNAMIC SELECT
- RACE START
- AMG Performance 4MATIC+
- AMG Performance Exhaust System
- 20" Aluminum Alloy Wheels

## *Comfort & Convenience*

- COMAND NTG 5.5
- MAGIC VISION CONTROL
- Ambient Lighting in 64-colors with Individual Zones
- Active Multicontour Front Seats
- NFC Wireless Charging Front
- ENERGIZING COMFORT Function
- Smartphone Integration with Apple CarPlay and Android Auto
- Soft-close doors and electronic trunk closer
- Touch Control Buttons on steering wheel
- Fixed Panorama Roof
- New generation SmartKey with Affalterbach Crest
- DINAMICA Headliner

## *Safety & Security*

- Lane Tracking Package (Blind Spot Assist & Lane Keep Assist)
- Surround View System
- Active Brake Assist
- LED Intelligent Light System
- ATTENTION ASSIST
- Active Parking Assist
- Mercedes me connect® with trail period
- OLED Taillights

## Non-metallic Paints



**040**  
Black  
*Option price: \$0*

## Metallic Paints & Magno Paints



**183**  
Magnetite Black  
*Option price: \$0*



**197**  
Obsidian Black  
*Option price: \$0*



**775**  
Iridium Silver  
*Option price: \$0*



**890**  
Lunar Blue  
*Option price: \$0*

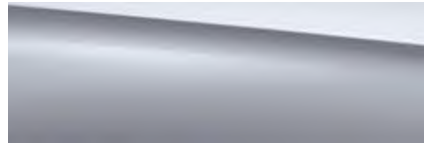

**988**  
Diamond Silver  
*Option price: \$0*



**998**  
Anthracite Blue  
*Option price: \$0*



**989**  
Emerald Green  
*Option price: \$0*



**992**  
Selenite Grey  
*Option price: \$0*

## designo® Paints



**799**  
Diamond White  
*Option price: \$795*



**049**  
Cashmere White Magno  
*Option price: \$3,950*



654  
20" AMG 5-Spoke Wheels  
Titanium  
*Option price: \$0*  
R01, B51



647  
20" AMG Forged 10-Spoke  
Wheels, Silver  
*Option price: \$1,700*  
R01, B51



648  
20" AMG Forged 10-Spoke  
Wheels, Black  
*Option price: \$2,200*  
R01, B51



RTR  
20" AMG Forged Cross-Spoke  
Wheels, Silver  
*Option price: \$1,700*  
R01, B51



RTS  
20" AMG Forged Cross-Spoke  
Wheels, Black  
*Option price: \$2,200*  
R01, B51



753  
20" AMG Forged Twin 5-Spoke  
Wheels, Silver with Black Accents  
*Option price: \$1,700*  
R01, B51

<i>Code</i>	<i>Wheel Size</i>	<i>Description</i>	<i>Wheel Dimensions</i>	<i>Mobility</i>	<i>Availability</i>	<i>MSRP</i>
654	20"	AMG 5-Spoke Wheels, Titanium w/ black Accents	255/40 R 20 on 8.5 J x 20 ET39 (Front) 285/35 R 20 on 9.5 J x 20 ET39 (Rear)	R01, B51	S 63	\$0
647	20"	AMG Forged 10-Spoke Wheels, Silver	255/40 R 20 on 8.5 J x 20 ET39 (Front) 285/35 R 20 on 9.5 J x 20 ET39 (Rear)	R01, B51	S 63	\$1,700
648	20"	AMG Forged 10-Spoke Wheels, Black	255/40 R 20 on 8.5 J x 20 ET39 (Front) 285/35 R 20 on 9.5 J x 20 ET39 (Rear)	R01, B51	S 63	\$2,200
RTR	20"	AMG Forged Cross-Spoke Wheels, Silver	255/40 R 20 on 8.5 J x 20 ET39 (Front) 285/35 R 20 on 9.5 J x 20 ET39 (Rear)	R01, B51	S 63	\$1,700
RTS	20"	AMG Forged Cross-Spoke Wheels, Black	255/40 R 20 on 8.5 J x 20 ET39 (Front) 285/35 R 20 on 9.5 J x 20 ET39 (Rear)	R01, B51	S 63	\$2,200
753	20"	20" AMG 5-Twin-Spoke Forged Wheels, Silver with Black Accents	255/40 R 20 on 8.5 J x 20 ET39 (Front) 285/35 R 20 on 9.5 J x 20 ET39 (Rear)	R01, B51	S 63	\$1,700



851  
Black

*Option price: \$0*

*61U Black or 68U Crystal Grey DINAMICA Headliner*



855  
Porcelain/Esspresso Brown

*Option price: \$0*

*65U Porcelain DINAMICA Headliner*

# Interior Upholstery – *designo* Exclusive Nappa Leather



561

*designo* Black Exclusive Nappa Leather  
61U Black or 68U Grey DINAMICA Headliner  
S63: \$3,250



565

*designo* Porcelain/Esspresso Brown Exclusive Nappa Leather  
65U Porcelain DINAMICA Headliner  
S63: \$3,250



568

*designo* Crystal Grey/Black Exclusive Nappa Leather  
61U Black or 68U Grey DINAMICA Headliner  
S63: \$3,250



584

*designo* Saddle Brown/Black Exclusive Nappa Leather  
61U Black DINAMICA Headliner  
S63: \$3,250



585

*designo* Porcelain/Deep-Sea Blue Exclusive Nappa Leather  
65U Porcelain DINAMICA Headliner  
S63: \$3,250



595

*designo* Porcelain/Titian Red Exclusive Nappa Leather  
65U Porcelain DINAMICA Headliner  
S63: \$3,250





567

*designo* Bengal Red/Black Exclusive Nappa Leather

61U Black DINAMICA Headliner

S63: \$3,250

<i>Code</i>	<i>Upholstery</i>	<i>Seats</i>	<i>Floor Mats</i>	<i>Upper Dash/Lower Dash</i>	<i>Seat Belts</i>	<i>Steering Wheel</i>	<i>Headliner</i>
851	Nappa Leather Black	Black	Black	Black	Black	Black	Black or Crystal Grey
855	Nappa Leather Porcelain/ Espresso Brown	Porcelain	Porcelain	Espresso Brown/Porcelain	Porcelain	Porcelain	Porcelain
561	<i>designo</i> Black Exclusive Nappa Leather	Black	Black	Black/Black	Black	Black	Black
565	<i>designo</i> Porcelain/Espresso Brown Exclusive Nappa Leather	Porcelain	Porcelain	Espresso Brown/Porcelain	Porcelain	Porcelain	Porcelain
568	<i>designo</i> Crystal Grey/Black Exclusive Nappa Leather	Crystal Grey	Crystal Grey	Crystal Grey/Black	Crystal Grey	Black	Black or Crystal Grey
584	<i>designo</i> Saddle Brown/Black Exclusive Nappa Leather	Saddle Brown	Black	Black/Saddle Brown	Black	Black	Black
585	<i>designo</i> Porcelain/Deep Sea Blue Exclusive Nappa Leather	Porcelain	Deep Sea Blue	Deep Sea Blue/Porcelain	Porcelain	Porcelain	Porcelain
595	<i>designo</i> Porcelain/Titian Red Exclusive Nappa Leather	Porcelain	Porcelain	Titian Red/Porcelain	Porcelain	Porcelain	Porcelain
567	<i>designo</i> Bengal Red/Black Exclusive Nappa Leather	Bengal Red	Black	Black/Bengal Red	Black	Black	Black



729

Black High-gloss Poplar Wood  
Option Price: *No charge*



H29

Brown High-gloss Burl Walnut Wood  
Option Price: *No charge*

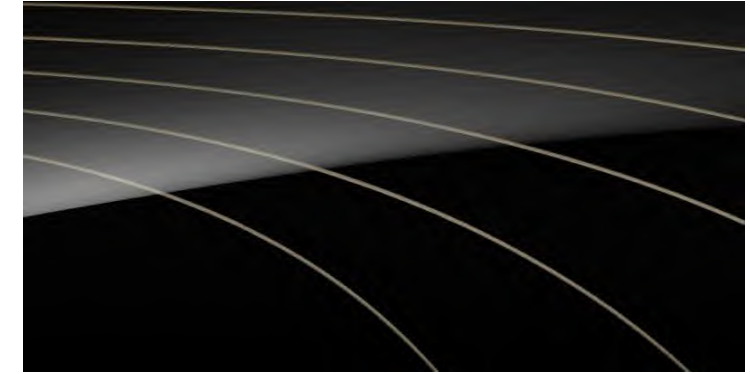

H16

*designo* Black Piano Lacquer Flowing Lines  
Option Price: *\$1,300*



H21

*designo* Black Piano Lacquer  
Option Price: *\$800*

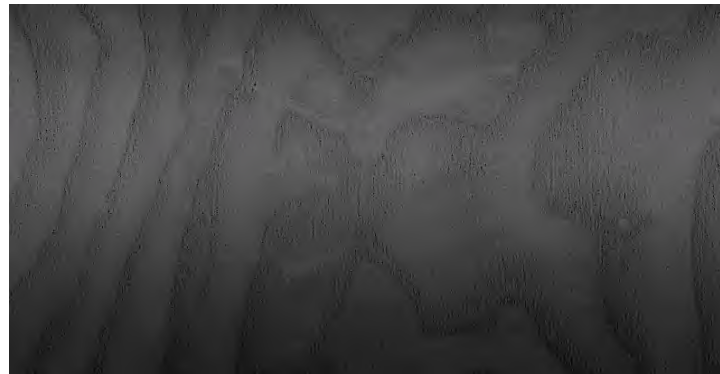

H30

Grey Satin-Finish Ash Wood  
Option Price: *\$800*

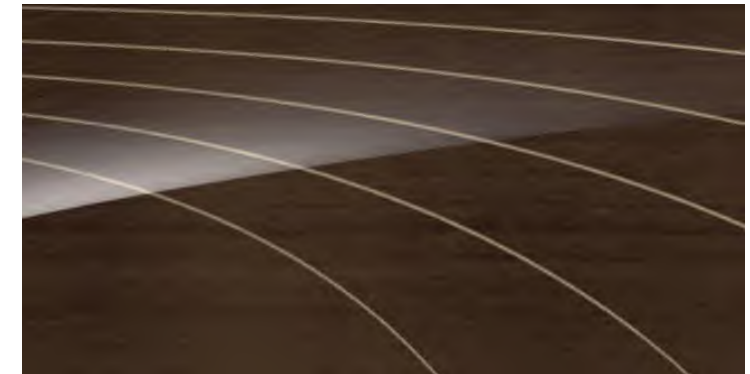

H26

*designo* Magnolia Flowing Lines  
Option Price: *\$1,300*

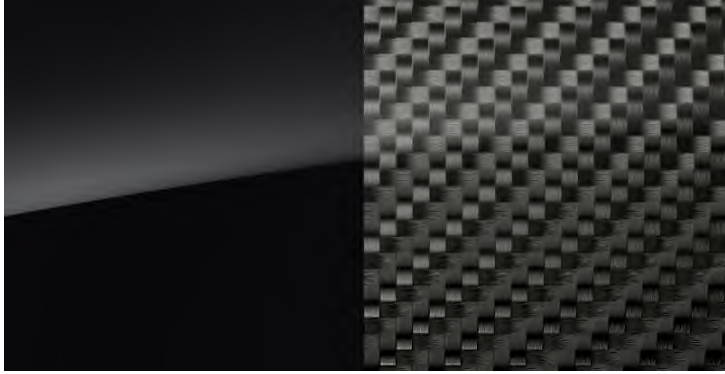

H10

AMG Carbon Fiber & Black Piano Lacquer  
Option Price: \$3,700

## *New Trim Options*



**Grey Satin-Finish Ash Wood (H30)**



**Brown High-gloss Burl Walnut Wood (H29)**



***designo* Magnolia Flowing Lines (H26)**

<i>Code</i>	<i>Packages</i>	<i>Availability</i>	<i>MSRP</i>
DP1	<b>Premium Package</b> <ul style="list-style-type: none"> <li>▪ 432 – Multicontour Front Seats with Massage Feature</li> <li>▪ 463 – Head-Up Display</li> <li>▪ 501 – Surround View System</li> <li>▪ 902 – Front Variable Heated Seats Plus</li> </ul>	S 63	\$ Standard
DB0	<b>Warmth and Comfort Package</b> <ul style="list-style-type: none"> <li>▪ 443 – Heated Steering Wheel</li> <li>▪ P68 – Heated Front Door Panels and Center Console</li> <li>▪ 872 – Heated Rear Seats</li> </ul>	S 63	\$ 1,990
DA2	<b>Driver Assistance Package</b> <ul style="list-style-type: none"> <li>▪ Active Lane Change Assist</li> <li>▪ Extended Restart in Stop-and-Go Traffic</li> <li>▪ Route-Based Speed Adaption</li> <li>▪ Active Distance Assist DISTRONIC</li> <li>▪ Active Steering Assist</li> <li>▪ Active Speed Limit Assist</li> </ul>	S 63	\$ 2,250
DC4	<b>AMG Exterior Carbon Fiber Package</b> <ul style="list-style-type: none"> <li>• Carbon Fiber Lower front A-wing blade</li> <li>• Carbon Fiber Lower rear apron</li> <li>• Carbon Fiber Side View Mirror covers</li> <li>• Carbon Fiber Rocker panel insert</li> <li>• Carbon Fiber Engine Cover</li> </ul>	S63	\$ 6,500
DC3	<b>AMG Aerodynamics Package</b> <i>(Can be combined with Carbon Fiber and Night Packages)</i> <ul style="list-style-type: none"> <li>• Larger Front Splitter in Carbon Fiber</li> <li>• Rear Spoiler Lip in Carbon Fiber</li> </ul>	S63	\$ 2,850

<i>Code</i>	<i>Options</i>	<i>Availability</i>	<i>MSRP</i>
B07	<b>AMG Ceramic Compound Braking System</b>	S 63	\$ 8,950
308	<b>Refrigerated compartment in the rear</b>	S 63	\$ 1,100
597	<b>Heated Windshield</b>	S 63	\$ 550
U70	<b>AMG Red-Painted Brake Calipers</b>	S 63	\$ 700
P60	<b>AMG Night Styling Package</b> <ul style="list-style-type: none"> <li>• High-gloss black lower front A-wing blade</li> <li>• High-gloss black lower rear apron trim</li> <li>• High-gloss black Side View Mirror covers</li> <li>• High-gloss black Rocker panel insert</li> <li>• Black chrome tailpipes</li> </ul> <b>Note:</b> May be combined with DC3 Carbon Fiber Exterior Package	S 63	\$ 750
811	<b>Burmester® High-End 3D Surround Sound System</b>	S 63	\$ 6,400
398	<b>MAGIC SKY CONTROL</b>	S 63	\$ 2,500
610	<b>Night View Assist PLUS</b> (Requires DA2 Driver Assistance Package)	S 63	\$ 2,260
5U5	<b>Swarovski® Crystal Headlamps</b> (Requires 610)	S 63	\$ 1,750
B14	<b>AMG Carbon Fiber Engine Cover</b>	S 63	\$ 1,500
P34	<b>Exclusive Interior Control Code</b> (Required for 5XX Exclusive Nappa Leather Interiors)	S 63	\$ 0
U88	<b>AMG Drive Unit Steering Wheel Buttons</b>	S 63	\$ TBA
<i>Code</i>	<i>VPC Installed Accessories</i>	<i>Availability</i>	<i>MSRP</i>
068	<b>Wheel Locks</b>	All Models	\$ 150

## Steering Wheels



**AMG Performance Steering Wheel – Nappa Leather (L6J)**  
Standard

- Black Wheel Automatically Applied to Black Two-Tone Interiors 851, 561, 568, 584, 567
- Porcelain Wheel Automatically Applied to Porcelain Interiors 855, 565, 585, 595
- 3-spoke design
- Heavily embossed in the grip area
- Flattened bottom section
- Touch Control buttons



**AMG Performance Steering Wheel – Nappa Leather & DINAMICA (L6K)**  
Optional (\$500)

- Not with Interiors 855, 565, 585, 595
- Black
- 3-spoke design
- DINAMICA in grip area
- Flattened bottom section
- Touch Control buttons



**AMG Performance Steering Wheel – Wood/Nappa Leather (L6L)**  
Optional (\$600)

- Not available with H26, H29 or H30 Interior Trims
- 3-spoke Nappa Leather design with Wood Inserts
- Heavily embossed in the grip area
- H10 or H16 Trims complemented by Black Piano Lacquer Inserts
- Flattened bottom section
- Touch Control buttons



**AMG Performance Steering Wheel – Carbon Fiber/DINAMICA (L6H)**  
Optional (\$900)

- Only available with H10 Interior Trim
- 3-spoke design
- Carbon Fiber Inserts at Top and Bottom of Wheel
- DINAMICA in grip area
- Flattened bottom section
- Touch Control buttons



## *Brakes*



**AMG Silver-Painted Brake Calipers (B06)**  
*Standard*

- The brake calipers painted in a silver color with AMG logo convey a sense of value and sportiness
- Front axle: 15.4" front brake discs, internally ventilated and perforated with 6-piston fixed calipers
- Rear axle: 14.2" rear brake discs, internally ventilated and perforated with single-piston floating caliper



**AMG Red-Painted Brake Calipers (U70)**  
*Optional (\$700)*

- Painting the brake calipers in red visually underscores the high performance of the composite braking system
- Front axle: 15.4" front brake discs, internally ventilated and perforated with 6-piston fixed calipers
- Rear axle: 14.2" rear brake discs, internally ventilated and perforated with single-piston floating caliper

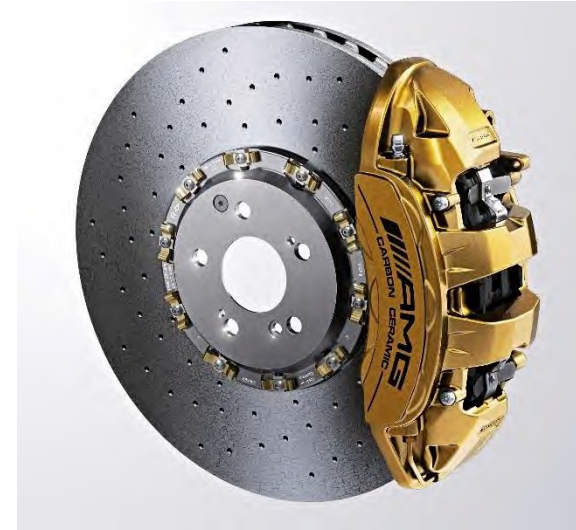

**AMG Carbon Ceramic Braking System (B07) – [See Advisory](#)**  
*Optional (\$8,950)*

- Bronze calipers are the signature of the AMG Carbon Ceramic Braking system
- Weight reduction of 40% compared with conventional compound brake discs
- Front axle: 16.5" front brake discs, internally ventilated and perforated with 6-piston fixed calipers
- Rear axle: 14.2" rear brake discs, internally ventilated and perforated with single-piston floating caliper

## Advisory on B07 AMG High-Performance Ceramic Compound Braking System



The AMG Ceramic Compound Braking system has numerous benefits – namely, it is 40% lighter than a conventional steel braking system, offers significantly longer service life for the brake rotors, and provides exceptional resistance to brake fade under repeated aggressive stops.\*

The materials in your AMG Ceramic Compound Braking system were derived from Formula One technology, and therefore will perform differently than conventional brakes.

Especially when cold, this ceramic composite material will resonate during braking and potentially feel less responsive under light brake pressure but with no loss in braking power. You will hear sounds, e.g. squealing, that you might not expect and which may be louder than what you are used to during ordinary everyday braking maneuvers – rest assured that this is a normal operating characteristic for this brake system, and is a by-product of the unique properties of the material. Mercedes-AMG recommends that the driver engage the brakes in an assertive manner in order to mitigate some of this noise during normal operation; Mercedes-AMG also recommends that the brakes be brought up to operating temperature before use in high-performance driving situations in order to improve braking performance.

*\*Brake weight based on AMG Germany official measurements, Service life based on F1 Safety car longevity and is dependent on individual driving style and conditions and will vary. Brake pads and rotors should be regularly serviced to ensure proper wear. Please reference your Mercedes-AMG Maintenance Booklet or contact your dealer for scheduled intervals.*

## *P60 AMG Exterior Night Package*

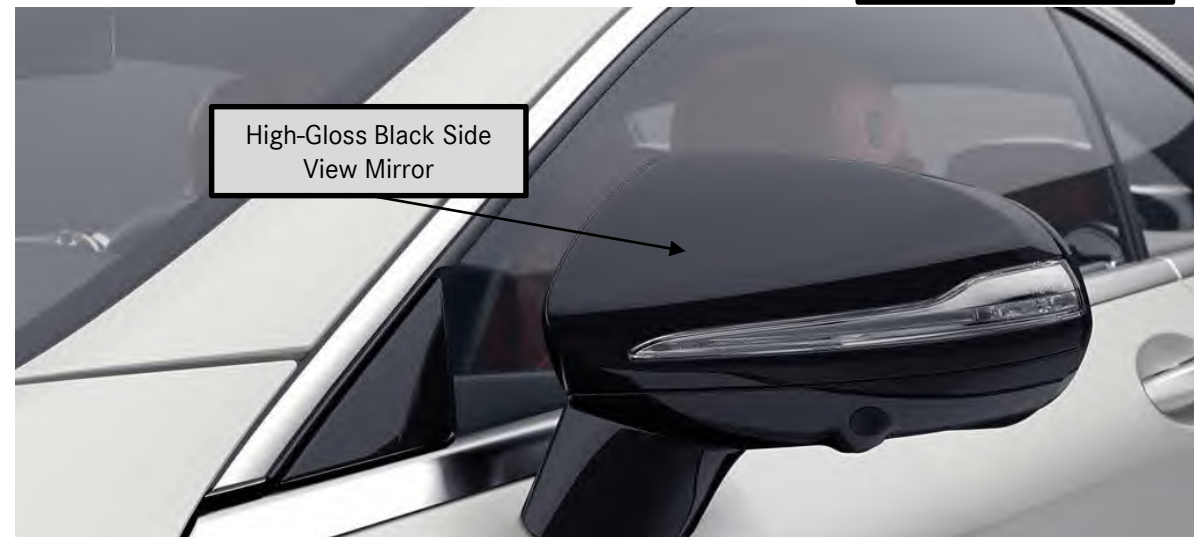

## *DC4 AMG Exterior Carbon Fiber Package*

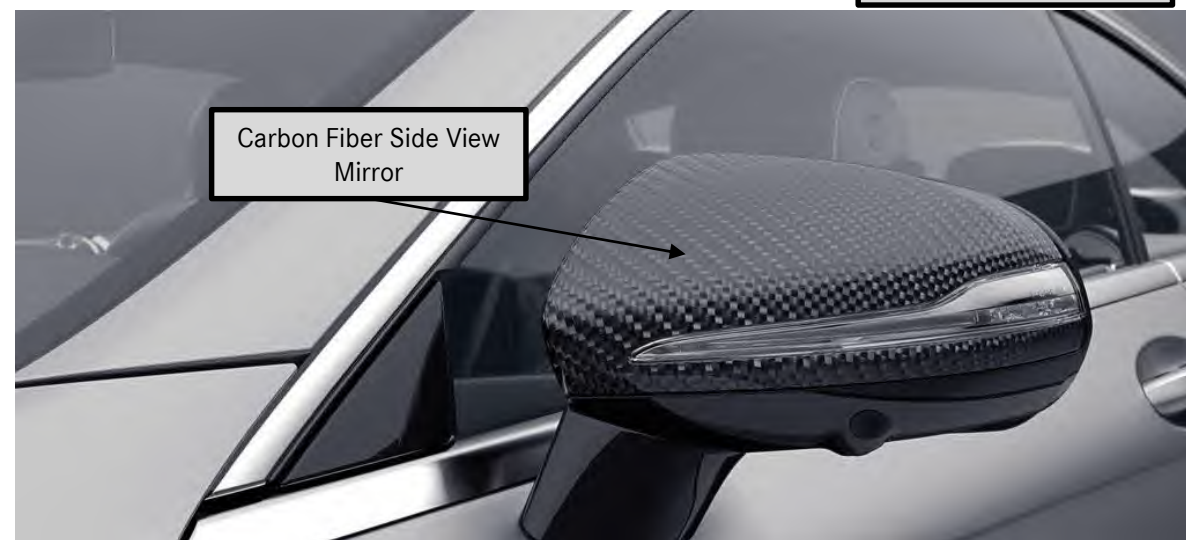

## DC3 AMG Aerodynamics Package (Shown here in conjunction with Carbon Fiber Package)



## *AMG Sport Suspension*



**AMG Sport Suspension based on AIRMATIC**  
*Standard on S63*

**Outstanding agility and vehicle control is ensured by the AMG sports suspension based on AIRMATIC, with AMG- specific kinematics, elastokinematics and parameters of the variable damper control.**

- Combines outstanding agility and vehicle control with unimpaired comfort on long journeys
- two suspension setups: "Sport" and "Comfort"
- AMG-specific kinematics, elastokinematics and parameters of the variable damper control
- Optimized volume of air in the air suspension system and a progressive piston geometry reduce body roll and pitching
- Stiff kinematics combined with coordinated damping ensure the best possible handling characteristics right up to the physical limits
- Handling characteristics virtually independent of the vehicle load, thanks to increased pressure in the air spring when weight is added
- Suspension can be raised on poor surfaces, automatic lowering in "Sport" mode and from 75mph in "Comfort" mode

## *AMG S63 Coupe - designo Exclusive Nappa Leather Interior in Detail*



	<b>S 63</b>
Engine Configuration	Handcrafted Mercedes-AMG 4.0L V8 biturbo Engine
Power (hp)	603 @ 5,500-6,000 rpm
Torque (lb-ft)	664 lb-ft @ 2,750-4,500 rpm
Displacement (cc)	3982
Acceleration 0-60 mph (sec)	3.4
Fuel Economy (Cty/Hwy/Comb)	tba
Top Speed (mph)	186
Fuel Requirement (Octane)	91
Transmission	AMG SPEEDSHIFT® MCT 9-speed transmission
Transmission Speeds	9
Drive Configuration	AMG Performance 4MATIC+ permanent all-wheel drive with fully-variable torque split
Fuel Tank Size (gallons)	24.3
Trunk Size (cubic feet)	14.1
Curb Weight (lbs)	4,586
Maximum Load (lbs)	1,025
Vehicle Length (in.)	198.86
Vehicle Width w/ exterior mirrors (in.)	82.99
Vehicle Height (in.)	55.59 / 55.98
Wheelbase (in.)	115.94
Track Width Front/Rear (in.)	64.65 / 64.69
Coefficient of Drag (Cd)	0.33



# Specifications\* – S63

