

2021 S-Class Sedan Order Guide



Table of Contents

1	General Information
2	What's New
3	Models
4	Equipment
4.1	Standard Equipment
4.2	Exterior Paint Colors
4.3	Wheels
4.4	Interior Upholstery
4.6	Interior Trims
4.7	Packages
4.8	Options
4.9	Specifications
5	Options In Detail
6	Build Recommendations
7	Gallery



General Information

Important Note

The information presented in this guide is based on the most current information available and is intended for internal use only. Mercedes-Benz reserves the right to make changes at any time, without notice, to colors, materials, equipment, special specifications and models.

Pricing may not yet be finalized for some models or options.

Due to variances among monitors and printers the colors that appear on your screen and printouts may not be exact.

For illustrative purposes, some images may show vehicles with European Specification.

Revision History

Date	Description
09/11/2020	Publish DOG



What's New

Standard Equipment

- Powered, Rapid-Heated, and Ventilated Front Seats with Massaging Feature, 4-Position Memory, and Lumbar Support
- Active Ambient Lighting with Illuminated Door Sill Panels
- MBUX with Navigation and "Hey Mercedes" Voice Control
- Wireless Smartphone Integration (Apple Carplay, Android Auto™)
- Fingerprint Sensor
- Seamless Door Handles
- Online Music Streaming
- Driver Assistance Package
- Front LED Logo Projectors
- 12.8" OLED Touchscreen Center Display
- Burmester® 3D Surround Sound System with Sound Personalization
- Augmented Video for Navigation
- Powered Side Rear Sunshades
- 8 USB-C Ports (4 Front, 4 Rear) and 115V Power Supply (Rear)
- Toll Gate Transponder
- 360 Degree Surround View Camera
- Dash Camera

Paints

- 346- Onyx Black
- 831- Graphite Grey
- 922- Cirrus Silver
- 660- Rubellite Red
- 859- Mojave Silver

Trims

- H02- FINELINE "Anthracite" Natural Grain
- H38- Silver Aluminum Fanned Walnut Wood
- H75- Stainless Steel-Metal Blended Black/Silver

Upholstery

- 804- Sienna Brown & Black
- 504- Exclusive Sienna Brown & Black
- 507- Exclusive Carmine Red & Black
- 805- Macchiato & Magma Grey
- 505- Exclusive Macchiato & Magma Grey
- 508- Exclusive Silver Grey & Black

Options

- 201- 4.5 Degree Rear Axle Steering
- 811- Burmester® High-End 4D Surround Sound System

Packages

- Choose from three Lines: Luxury Line, AMG Line, and Executive Line
- DF0- 3D Technology Package

S-Class Lines

The all-new S-Class is generously equipped with customer favorites - the Driver Assistance Package, Surround View Camera, and Massaging and Ventilated Seats among others, PLUS new technologies including the 12.8" OLED Touchscreen, Seamless Door Handles, Active Ambient Lighting, Wireless Apple Carplay/Android Auto, and more. With the new, enriched level of standard equipment, specifying and ordering an S-Class is easier than ever. Choose from one of three Lines and then select standalone options for each. Paint and upholstery are openly available across all three Lines, to be tailored to your customers' tastes.

MY21 S-Class Line Offering Structure

2021 Standard Equipment for ALL LINES			
	Driver Assistance Package Power Sunshades on Rear Seats Active Ambient Lighting Active Multicontour Seats Door Comfort System	Surround View Camera 360 Degree View Active Ambient Lighting Power Window Lock/Free Toll Gate Transponder	12.8" OLED Touchscreen Center Display Augmented Reality for Navigation eCall (USA) with Emergency Services
Line Choice	Luxury Line	AMG Line	Executive Line
Included Line Contents	<ul style="list-style-type: none"> • No additional Line content 	<ul style="list-style-type: none"> • 201 High Package • Choice of 200 wheel 	<ul style="list-style-type: none"> • Executive Rear Seat Package • Massaging, Heated, Ventilated, Power, Memory Rear Seats with Neck Heating • Strength & Comfort Package • 1000W Rear Seat Entertainment with Tablet and 7 Wireless Chargers • Includes Trim and Design Roll Buttons • Active Climate Control • Rear Wireless Charging • ENERGIZING Comfort Front and Rear • Rear Frontal Airbags and Rear Sidebags • 18 Degree Rear Axle Steering
Line Specific Options	<ul style="list-style-type: none"> • 443 Heated Steering Wheel • 811 Burmester 4D Surround System • DF0-3D Technology Package • 500-Strength & Comfort Package • Exclusive Nappa Leather 	<ul style="list-style-type: none"> • 443 Heated Steering Wheel • 811 Burmester 4D Surround System • DF0-3D Technology Package • 500-Strength & Comfort Package • Exclusive Nappa Leather • 201 High Package • 201 4.5-Degree Rear Axle Steering 	<ul style="list-style-type: none"> • 811 Burmester 4D Surround System • DF0-3D Technology Package • Exclusive Nappa Leather
Line Specific Trim Choices	H02, H04, H07, H08	H02, H07, H08, H09, H10	H02, H04, H07, H08
Line Specific Wheel Choices	194, 404, H02	H02, H07, H08, H09, H10	194, 404, H08
Paint/Up	All Codes	All Codes	All Codes



Luxury Line



Standard Equipment

- P21-Air Balance Package
- Driver Assistance Package
- 297- Electric Sunblinds in Rear Doors
- 401- Ventilated Front Seats
- 432- Active Multicontour Seats
- 436-Front Comfort Headrests
- 501- 360 Surround View Camera
- 72B-USB Package Plus
- 878- Active Ambient Lighting
- 902- Front Heated Seats Plus
- 943-Toll Gate Transponder

Available Options

- DB0- Warmth & Comfort Package
- DF0- 3D Technology Package
- 443- Heated Steering Wheel
- 735- Exclusive Trim
- 811- Burmester High- End 4D Surround System
- Exclusive Nappa Leather 5xx (requires 735-Exclusive trim + P34-Exclusive Package)

See Trims and Wheels sections for available trims and wheels



AMG Line



Standard Equipment

- P21-Air Balance Package
- Driver Assistance Package
- 297- Electric Sunblinds in Rear Doors
- 401- Ventilated Front Seats
- 432- Active Multicontour Seats
- 436-Front Comfort Headrests
- 501- 360 Surround View Camera
- 72B-USB Package Plus
- 878- Active Ambient Lighting
- 902- Front Heated Seats Plus
- 943-Toll Gate Transponder

AMG Line Included Content

- AMG Body Styling
- Sport Package
- AMG Floor Mats

Available Options

- DB0- Warmth & Comfort Package
- DC1- Night Package
- DF0- 3D Technology Package
- 201- 4.5 Degree Rear Axle Steering
- 443- Heated Steering Wheel
- 735- Exclusive Trim
- 811- Burmester High- End 4D Surround System
- Exclusive Nappa Leather 5xx (requires 735-Exclusive trim + P34-Exclusive Package)

See Trims and Wheels sections for available trims and wheels

Executive Line



Standard Equipment

- P21-Air Balance Package
- Driver Assistance Package
- 297- Electric Sunblinds in Rear Doors
- 401- Ventilated Front Seats
- 432- Active Multicontour Seats
- 436-Front Comfort Headrests
- 501- 360 Surround View Camera
- 72B-USB Package Plus
- 878- Active Ambient Lighting
- 902- Front Heated Seats Plus
- 943-Toll Gate Transponder



Executive Line Included Content

- P07-Chauffeur Package Rear
- 306-Rear Beltbag
- 439- Easy Adjust Headrest
- 447- MBUX Rear Tablet
- 452-Electric Adjust Rear Seats
- 561- Design Belt Buckles Rear
- 582-4-Zone Climate Control
- 898- Wireless Charging Rear
- P43- Rear Seat Comfort
- 302- Rear Airbag
- 322- Rear Neck Heating
- 406- Active Multicontour Rear Seat
- 453- Executive Rear Seat
- PBT- Rear ENERGIZING COMFORT Package
- U58- 2 Wireless Headsets
- 854-MBUX High-End Rear Entertainment
- 223- Power Rear Seats
- 276- Rear Memory Seats
- 402- Ventilated Rear Seats
- 443- Heated Steering Wheel
- 903- Rear Seat Heating
- 906- Front Heated Armrest
- 907- Rear Heated Armrest
- PBS- Front ENERGIZING COMFORT Package
- 216- 10 Degree Rear Axle Steering
- 735- Exclusive Trim



Available Options

- DF0- 3D Technology Package
- 811- Burmester High- End 4D Surround System
- Exclusive Nappa Leather 5xx (requires 735-Exclusive trim + P34-Exclusive Package)

See Trims and Wheels sections for available trims and wheels



New Engine: S580 M176 V8 Engine

8-cylinder V-engine with 90° cylinder bank angle

Displacement: 3982 cc

Output: 496 hp

Torque: 516 lb-ft at 2000-4000 rpm

Stroke: 92 mm; Bore: 83 mm

Cylinder gap width: 90 mm



- 4-valves-per-cylinder design with two overhead camshafts per cylinder bank; camshaft adjustment on the intake and exhaust sides for spontaneous response, optimised load change behaviour and maximum durability
- Cylinder shut-off (CAMTRONIC) for fuel consumption reduction in partial-load range
- NANOSLIDE® (twin-wire-arc-sprayed) coating of cylinders for low friction and wear as well as maximum durability
- Torque plate honing for mechanical surface treatment of the cylinder sleeves in the "bolted state" to reduce consumption and friction
- Twin-turbocharging with two exhaust gas turbochargers between the two cylinder banks instead of exterior arrangement for compact engine design, optimum response and low exhaust gas emissions
- Mono-scroll exhaust gas turbocharger with boost pressure control via boost-pressure regulating valve for direct and spontaneous exhaust gas turbocharger response
- Spray-guided direct petrol injection of the 3rd generation with piezo injectors and demand-controlled multiple injection for high thermal efficiency and low emissions
- Separate low-temperature circuit for the charge air cooler to achieve optimum power output
- Efficient ancillary component drive via two short low-friction four-groove belt; water pump with chain drive
- Two-mass flywheel with centrifugal pendulum isolates the drivetrain from torsional vibration and supports excellent smoothness of operation
- Integrated starter alternator ISG2 (second generation)

Mercedes-Benz User Experience (Standard)



Extended MBUX Functions:

Say "Hey Mercedes", and your MBUX system awaits your commands. Personal profiles, predictive functions and a WiFi hotspot completely redefine the term digital networking

Many forms of interaction and personalization from every seat:

- The latest screen technologies and MBUX available for all occupants
- Standard 12.8" OLED Touchscreen Media display in portrait format as a visual highlight; features haptic feedback
- Up to three screens in the rear with the available Executive Line
- Up to seven different profiles are possible in the vehicle.
- Alongside entry of the Mercedes me PIN, new biometric and interconnected authentication functions ensure a high level of security. These are fingerprint (standard), face (optional with 3D Technology Package) and voice recognition (standard).
- New convenience functions include prepositioning of the driver's seat and outside mirrors according to body size
- The voice assistant "Hey Mercedes" listens even more carefully, and understands the occupants even better: "Hey Mercedes" can also be controlled from the rear. Several microphones help to tell the system which seat the voice is coming from. Flashing ambient lighting identifies the current speaker
- "Hey Mercedes" explains functions. The activation keyword "Hey Mercedes" is no longer necessary for certain applications. An incoming call can be taken direct with "Accept call", for example
- The appearance of the screens can be individualized with a choice of four display styles (Understated, Sporty, Exclusive, Classic) and three modes (Navigation, Assistance, Service)
- The number of classic controls has been greatly reduced: 27 fewer hardkeys (mechanical switches) than in the preceding model
- However, key functions such as the lights or windscreen wipers can still be operated directly. The climate control panel is permanently at the lower edge of the display

12.8" Central OLED Touchscreen (Standard)



OLED Technology: OLED stands for Organic Light Emitting Diode.

In contrast to LCD technology, an OLED display consists of several organic layers applied to a plastic substrate. In the S-Class the OLED display is located behind a glass facing, and in combination with the actuators and pressure sensors behind it, it provides a comprehensive control and display experience. Evaluation of the pressure exerted and haptic confirmation of touch commands makes extended functionalities possible.

OLED panels emit light when subjected to an electric current, and unlike an LCD they do not require external background lighting. Power is only consumed where pixels light up. Among other benefits, this ensures a better black level and even stronger contrasts. When showing typical video sequences, OLED technology has an up to 30 percent lower energy consumption than LCD technology.

Driver Assistance Package (Standard)



The standard Driver Assistance Package features Level 2 automated driving. State-of-the-art driving assistance systems support the driver according to the situation in terms of speed adjustment, steering, lane changes and the risk of collision. The risk of accidents is reduced – passengers and other road users are effectively protected.

Drivers are afforded a great degree of relief in monotonous traffic during lengthy trips, for example, and in bumper-to-bumper driving or traffic jams as well as before curves, roundabouts, T-junctions and the end of traffic jams, etc.

The fusion of different radar, ultrasound and camera sensors, map and navigation data, and live traffic information gives the customer more functionality compared to standard/individual functions.

The Driver Assistance Package Includes:

- Active Distance Assist DISTRONIC
- Active Speed Limit Assist with response to changing speed limits
- Extended automatic restarting
- Route-based speed adaptation
- Active Steering Assist
- Active Lane Change Assist
- Active Emergency Stop Assist
- Evasive Steering Assist
- Active Blind Spot Assist with exit warning
- Active Brake Assist with turning and cross-traffic function
- End-of-Tailback Emergency Braking
- PRE-SAFE® Impulse Side

Active Lane Change Assist

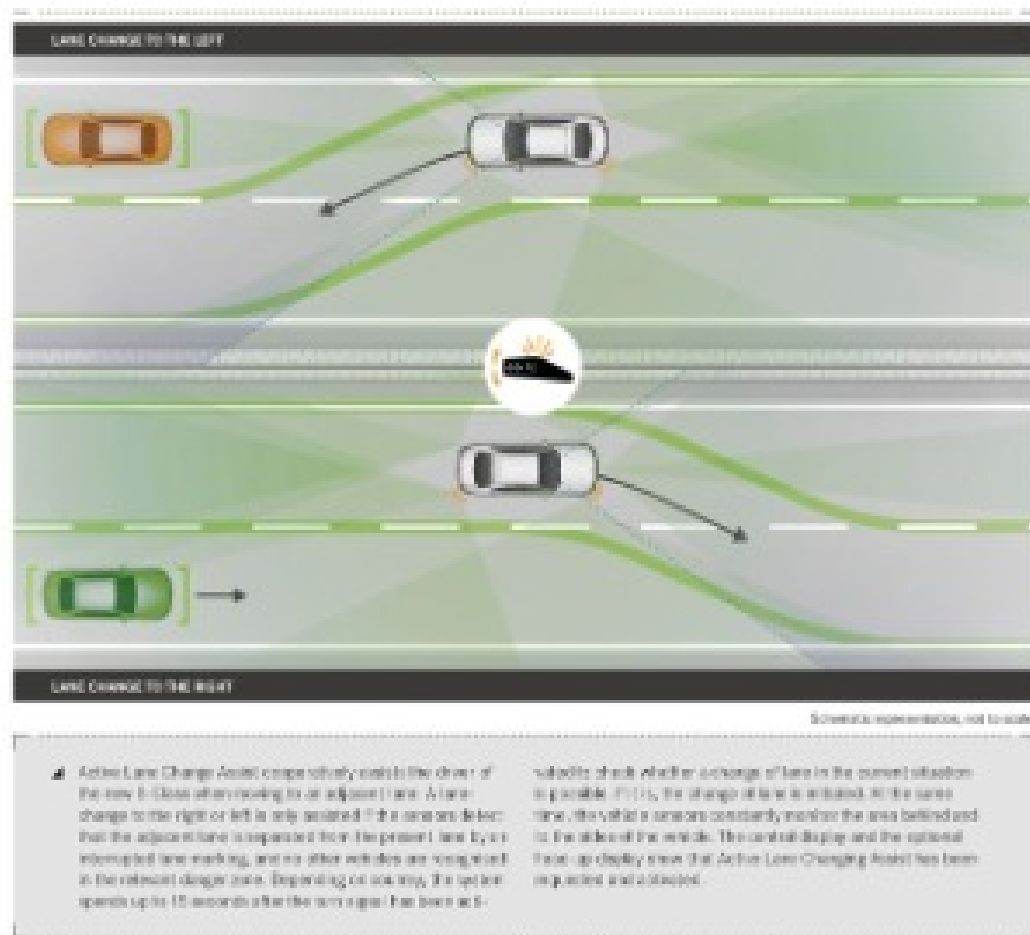

Dashcam (Standard)

The dashcam films and saves what's happening on the road in front of your vehicle – and also records the time and speed. This can help you document the sequence of events in an accident, for example, and provide you with supporting evidence if necessary. Or you can use the dashcam to record landscapes and routes to create your own automotive travel diary.

Components:

- Camera in the windshield
- Recording of videos with a resolution of 1280 x 720 pixels (720p) and a frame rate of 30 Hz
- Additional storage of speed and time embedded in the video signal
- Control menu in the media display
- Footage stored via USB stick using the Media Interface
- Video material can be viewed on a computer or the media display (only possible when vehicle is stationary) - for this the storage media must first be removed from the interface and reconnected



Active Ambient Lighting (Standard)

Key Argument:

With the active ambient lighting you are experiencing a technological leap. It links aesthetics with innovative driver information and extended functions. Wraparound light strips and trim elements meld to form an additional lighting level. This also supports driving assistance systems visually, thus emphasizing the intelligence and safety of your vehicle.

Components:

- Ambient lighting in 64 static colors, all colors can be selected individually
- High-quality Black-Panel light strip with a total of approx. 250 integrated and individually actuatable LEDs
- Diverse color moods, also with static or multicolor animated color sequences
- Driving assistance systems are also included and are supported visually
 - Active Blind Spot Assist
 - Active Lane Keeping Assist
 - Active Brake Assist
- Emotively appealing animations: welcome display or feedback in color when adjusting the air conditioning or interaction with the voice control
- Incorporation of active ambient lighting into the programs of the ENERGIZING comfort control (only in conj. with ENERGIZING packages)
- Variable setting of the brightness for automatic day and night switchover



Wireless Smartphone Integration - Apple Carplay, Android Auto™ - (Standard)



Smartphone Integration connects the mobile phone with the multimedia system wirelessly via Apple CarPlay™ and Android Auto™. This gives you convenient access to the most important applications of your smartphone. You can also use apps from third party service providers such as Spotify quickly and easily.

Keyless GO with Seamless Door Handles (Standard)



KEYLESS-GO puts an end to searches for the vehicle key. As soon as the convenience system detects your key in the immediate vicinity of the vehicle, the Seamless Door Handles automatically extend. When you drive off or lock the doors, they retract and are elegantly integrated into the side design – a clear technical and visual advantage for you.

Burmester® 3D Surround Sound System (Standard)

Experience greater audio performance with exquisite Burmester® sound. The high-quality speakers achieve impressive surround sound. You can specifically optimise this for the front and rear seats to intensify the listening experience. The unmistakable Burmester® speaker covers also enhance the interior visually.



- 15 high-performance speakers tuned to match the vehicle interior and each with its own amplifier channel
- DSP amplifier with a total output of 710 watts (2 x 120 watts, 7 x 50 watts, 6 x 20 watts)
- 2 broadband speakers in the front area for 3D sound
- Frontbass technology with subwoofers integrated into the body shell
- Sound optimisation for the front, rear or all seats
- 2 sound presets: Pure plus 3D-Sound for generating virtual surround sound, including multi-channel format support for true surround sound
- Sound Personalization function for sound reproduction tuned to individual music tastes
- Equalizer function for setting the bass, midrange and treble frequencies
- Noise compensation (VNC)

Burmester® High-End 4D Surround Sound System (811) Optional



This new fourth dimension comes courtesy of speaker-like resonators featuring sound massage. Surround speakers integrated into the seats also help to optimize the surround sound.

See Options in Detail section for more information

3D Technology Package- Augmented Reality Head-Up Display + 3D Instrument Cluster (DF0) Optional



The latest projector technology projects a virtual image with relevant information into your field of vision. The display area is very much larger compared to a classic Head-Up Display. Colorful, superimposed content appears at a virtual distance of 32.8 feet ahead of the vehicle. This directly perceptible information blends seamlessly with reality. It provides real added value, especially in complex situations where you need to make a turn. When you arrive, your destination is marked prominently with the street name and house number.

Keep your eye on the important things in the 3D instrument cluster. The three-dimensional warnings and functions of the driving assistance systems are immediately noticeable with their striking 3D and shaded effects. Another trailblazing effect is the fascinating 3D image of cars, trucks, buses or motorcycles ahead of your vehicle.

See Options in Detail section for more information



Models



S500V4 (223.163)

- MSRP: TBD
- Launch Date: TBD



S580V4 (223.176)

- MSRP: TBD
- Launch Date: First Half of 2021



Standard Equipment

S580V4



Performance & Handling

- 9G-TRONIC 9-speed Automatic Transmission
- DYNAMIC SELECT
- AIRMATIC Air Suspension
- ECO Start/Stop System

Comfort & Convenience

- Powered, Rapid-Heated, and Ventilated Front Seats with Massaging Feature, 4-Position Memory, and Lumbar Support
- Power Rear-Window Sunshade and Powered Side Rear Sunshades
- 12.3" Digital Instrument Cluster
- Garage Door Opener
- 12.8" OLED Touchscreen Center Display
- Fingerprint Sensor
- Active Ambient Lighting with Illuminated Door Sill Panels
- Power-Folding Mirrors
- KEYLESS-GO with Seamless Door Handles
- Dual-Zone Automatic Climate Control
- Soft Close Doors
- "Hey Mercedes" Voice Control
- Heat Insulating, Noise Insulating, and Infrared-Reflecting Laminated Glass
- Active Parking Assist
- Double Front Sunvisors
- MBUX with Navigation and "Hey Mercedes" Voice Control
- Panorama Roof
- Augmented Video for Navigation
- Wireless Charging Front
- Wireless Smartphone Integration (Apple Carplay, Android Auto™)
- KEYLESS Start
- Front LED Logo Projectors
- 8 USB-C Ports (4 Front, 4 Rear) and 115V Power Supply (Rear)
- Burmester® 3D Surround Sound System with Sound Personalization
- Nappa Leather Upholstery
- Electronic Trunk Closer
- SiriusXM Radio with Free Trial Period
- Air Balance Package
- Toll Gate Transponder
- Online Music Streaming

Safety & Security

- LED Intelligent Light System
- Mercedes-Benz eCall Emergency System
- Antitheft Alarm System
- Surround View Camera
- Driver Assistance Package
- Auto-Dimming Mirrors
- MAGIC VISION CONTROL
- PRE-SAFE Impulse Side
- Dash Camera



Paint

Non-Metallic Paints

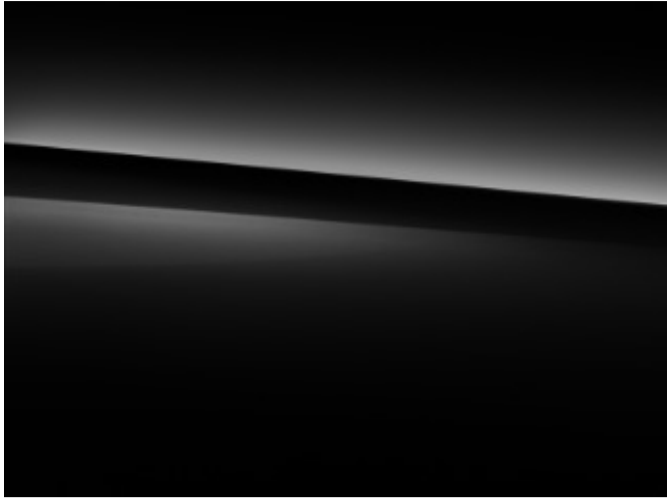

040 - Black

Metallic Paints

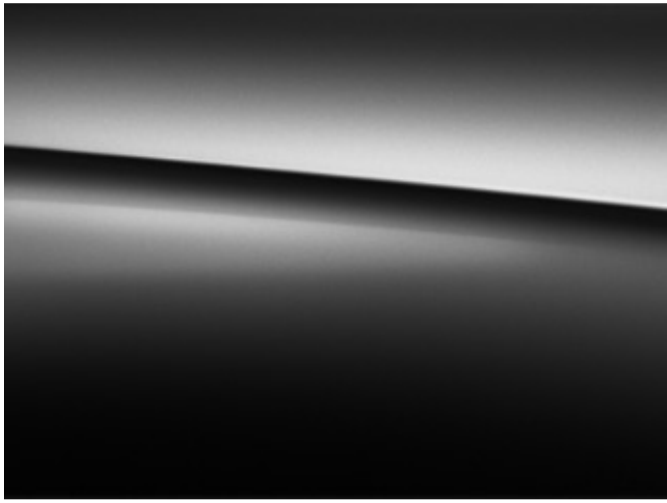

197 - Obsidian Black



346 - Onyx Black

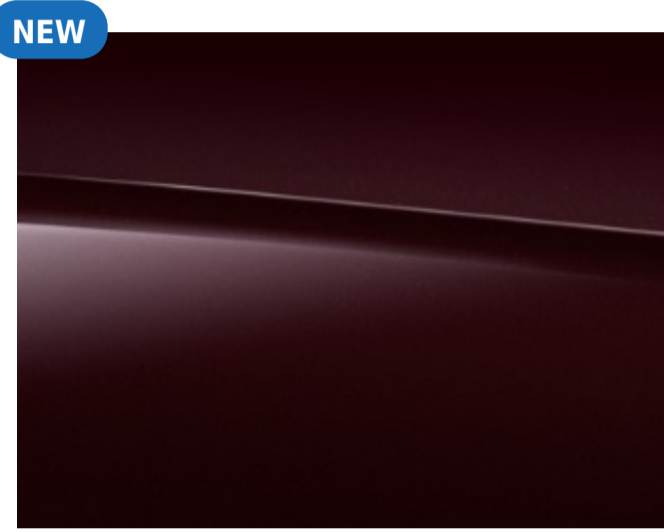

660 - Rubellite Red



831 - Graphite Grey

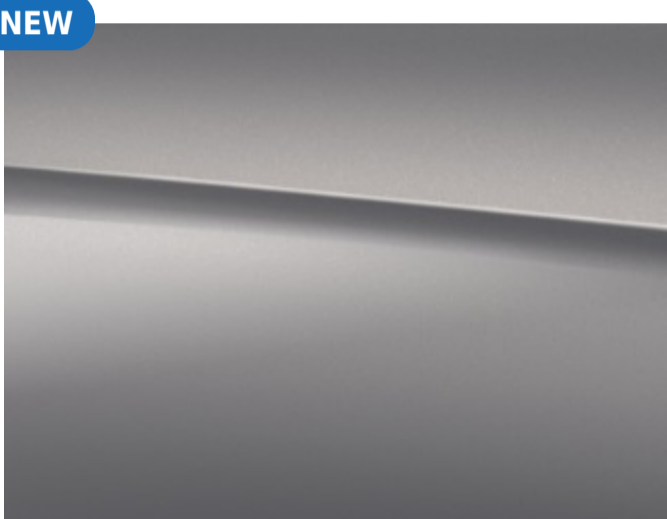

859 - Mojave Silver

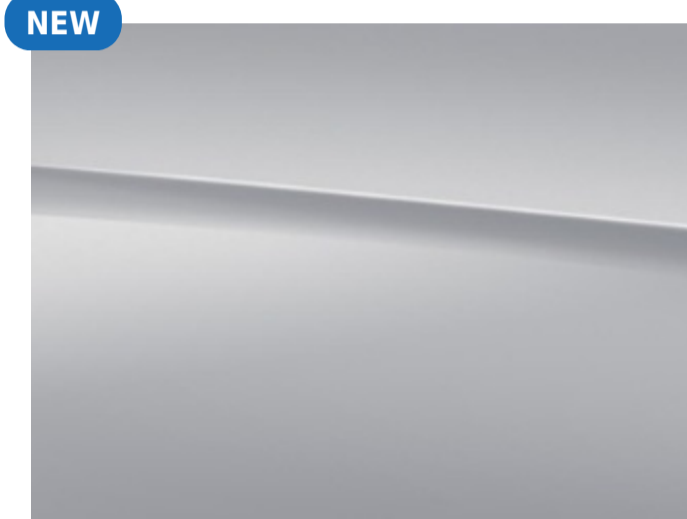

922 - Cirrus Silver

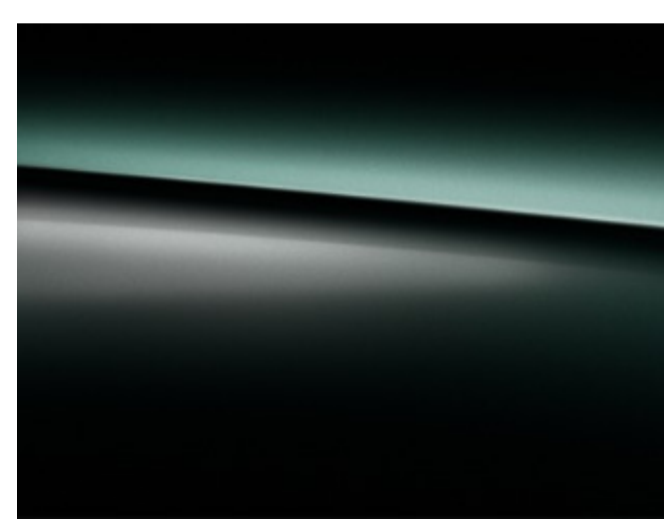

989 - Emerald Green

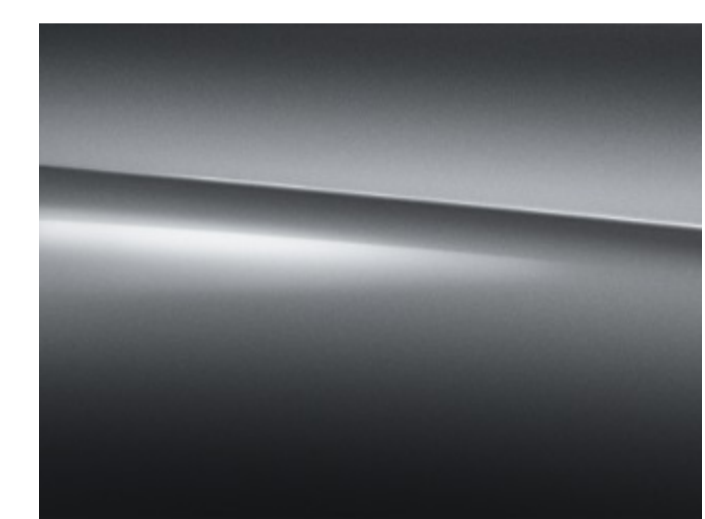

992 - Selenite Grey

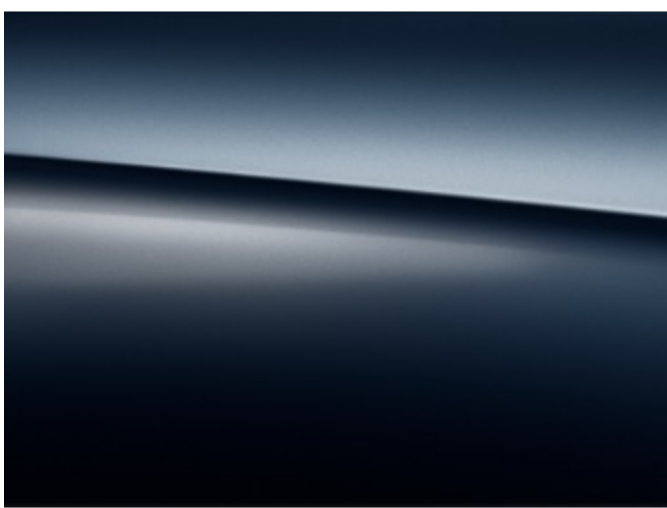

998 - Anthracite Blue

designo Paints



799 - designo Diamond White

<i>Code</i>	<i>Description</i>	<i>Availability</i>	<i>Price</i>
040	Black	S580V4	\$0
197	Obsidian Black	S580V4	\$0
346 (New)	Onyx Black	S580V4	\$0
660 (New)	Rubellite Red	S580V4	\$0
831 (New)	Graphite Grey	S580V4	\$0
859 (New)	Mojave Silver	S580V4	\$0
922 (New)	Cirrus Silver	S580V4	\$0
989	Emerald Green	S580V4	\$0
992	Selenite Grey	S580V4	\$0
998	Anthracite Blue	S580V4	\$0
799	designo Diamond White	S580V4	



Wheels



15R - 19" 10-Twin Multispoke Wheels

Only with Luxury (DX0) and Executive (DX2) Line
19"
R02 (All-Season Tires)
255/45 R19 on 8.5 J x 19 ET31.5



R60 - 19" AERO 10-Twin Multispoke Wheels

Only with Luxury (DX0) and Executive (DX2) Line
19"
R02 (All-Season Tires)
255/45 R 19 tyres on 8.5J x 19 ET31.5



60R - 20" Y-Multispoke Wheels

Only with Luxury (DX0) and Executive (DX2) Line
20"
R02 (All-Season Tires)
245/40 R 20 on 9 J x 20 ET34

DELAYED

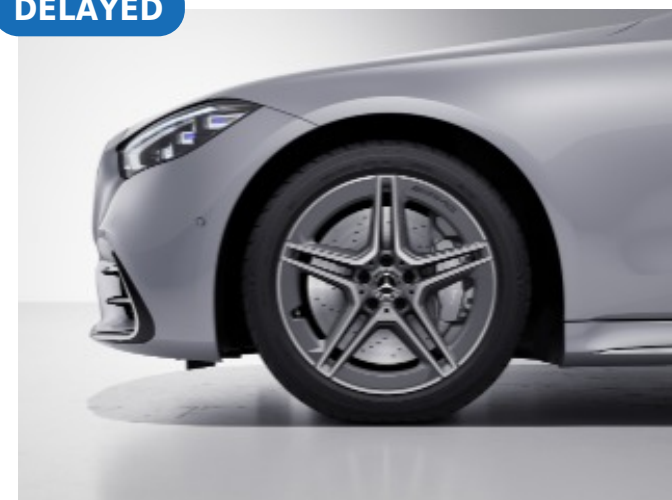

RZI - 19" AMG Twin 5-Spoke Wheels

Only with AMG Line (DX1)
19"
R02 (All-Season Tires)
255/45 R19 on 8.5 J x 19 ET31.5 (Front)
285/40 R 19 on 10J x 19 ET48.1 (Rear)



RVQ - 20" AMG Multispoke Wheels

Only with AMG Line (DX1)
20"
R02 (All-Season Tires)
255/40 R 20 on 9 J x 20 ET34 (Front) 285/35 R 20 on 10 J x 20 ET48.1(Rear)



RVR - 20" AMG Multispoke Wheels with Black Inlays

Only with AMG Line (DX1)/ Requires Night Package (DC1)
20"
R02 (All-Season Tires)
255/40 R 20 on 9 J x 20 ET34 (Front) 285/35 R 20 on 10 J x 20 ET48.1 (Rear)



RWK - 21" AMG V-Multispoke Wheels

Only with AMG Line (DX1)
21"
R01 (High-Performance Tires)
255/35 R 21 on 9 J x 21 ET48 (Front) 285/30 R 21 on 10 J x 21 ET48 (Rear)



RWN - 21" AMG V-Multispoke Wheels with Black Inlays

Only with AMG Line (DX1)/ Requires Night Package (DC1)
21"
R01 (High-Performance Tires)
255/35 R 21 on 9 J x 21 ET48 (Front) 285/30 R 21 on 10 J x 21 ET48 (Rear)

Code	Wheel Size	Description	Wheel Dimensions	Mobility	Availability	MSRP
15R	19"	Only with Luxury (DX0) and Executive (DX2) Line	255/45 R19 on 8.5 J x 19 ET31.5	R02 (All-Season Tires)	S580V4	\$0
R60	19"	Only with Luxury (DX0) and Executive (DX2) Line	255/45 R 19 tyres on 8.5J x 19 ET31.5	R02 (All-Season Tires)	S580V4	\$0
60R	20"	Only with Luxury (DX0) and Executive (DX2) Line	245/40 R 20 on 9 J x 20 ET34	R02 (All-Season Tires)	S580V4	
RZI (Delayed)	19"	Only with AMG Line (DX1)	255/45 R19 on 8.5 J x 19 ET31.5 (Front) 285/40 R 19 on 10J x 19 ET48.1 (Rear)	R02 (All-Season Tires)	S580V4	
RVQ	20"	Only with AMG Line (DX1)	255/40 R 20 on 9 J x 20 ET34 (Front) 285/35 R 20 on 10 J x 20 ET48.1(Rear)	R02 (All-Season Tires)	S580V4	
RVR	20"	Only with AMG Line (DX1)/ Requires Night Package (DC1)	255/40 R 20 on 9 J x 20 ET34 (Front) 285/35 R 20 on 10 J x 20 ET48.1 (Rear)	R02 (All-Season Tires)	S580V4	
RWK	21"	Only with AMG Line (DX1)	255/35 R 21 on 9 J x 21 ET48 (Front) 285/30 R 21 on 10 J x 21 ET48 (Rear)	R01 (High-Performance Tires)	S580V4	
RWN	21"	Only with AMG Line (DX1)/ Requires Night Package (DC1)	255/35 R 21 on 9 J x 21 ET48 (Front) 285/30 R 21 on 10 J x 21 ET48 (Rear)	R01 (High-Performance Tires)	S580V4	



Upholstery

Nappa Leather

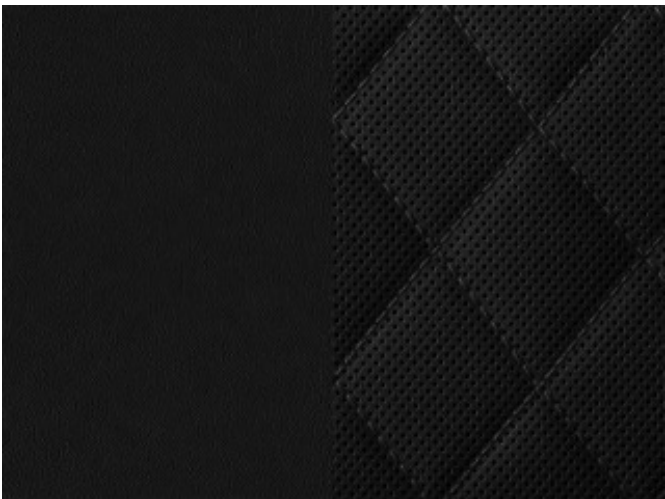

NEW

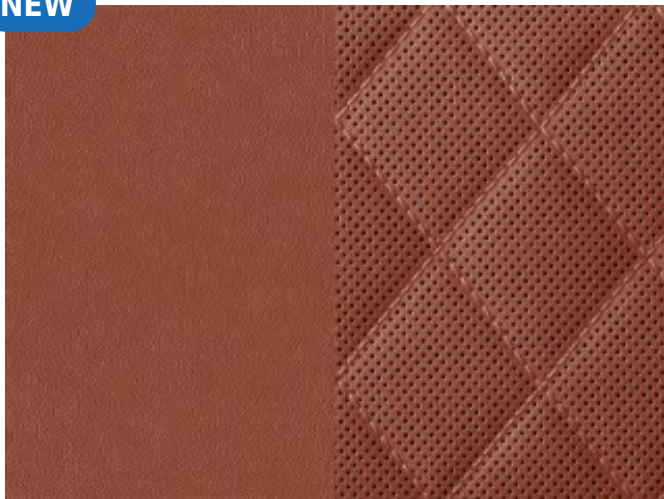

NEW

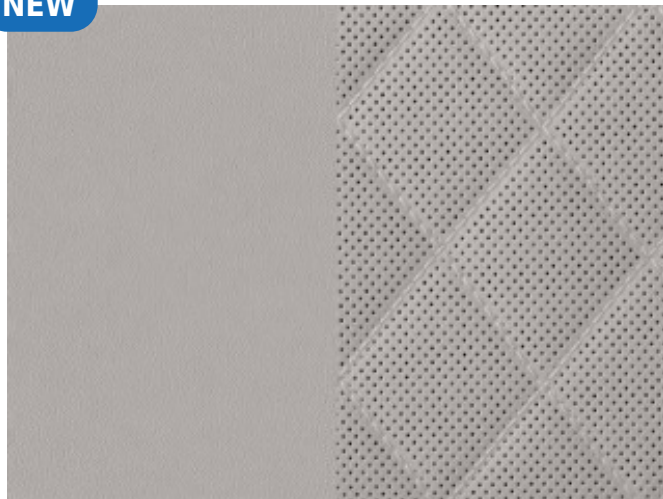

801 - Black

Requires 51U Black Headliner or 58U Grey Headliner

804 - Sienna Brown & Black

Requires 51U Black Headliner

805 - Macchiato & Magma Grey

Requires 55U Beige Headliner/Comes with Magma Grey Floor/FloorMats

Exclusive Nappa Leather

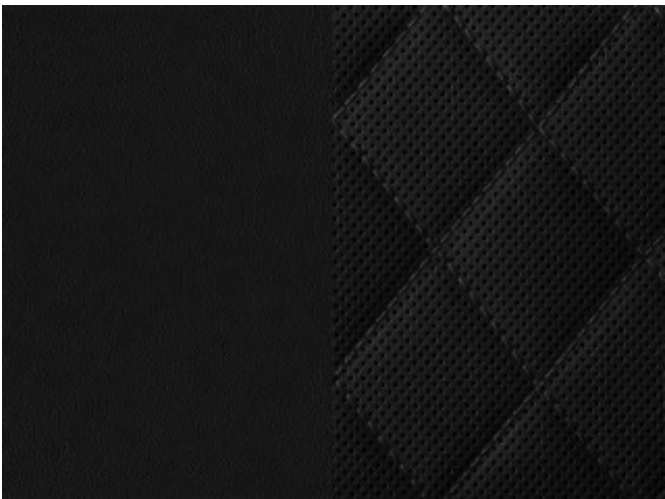

NEW

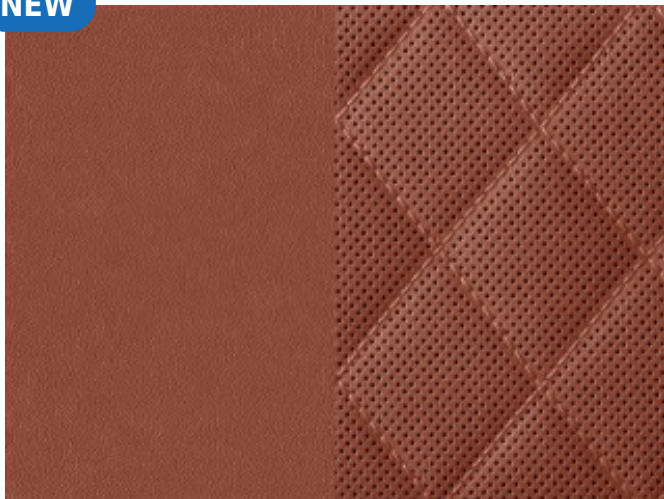

NEW

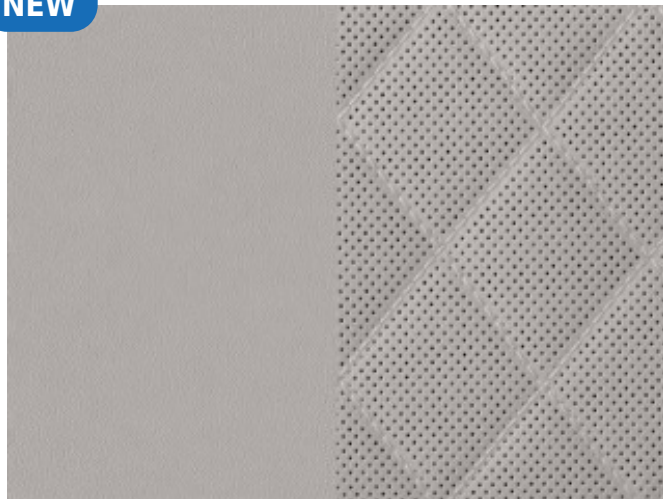

NEW

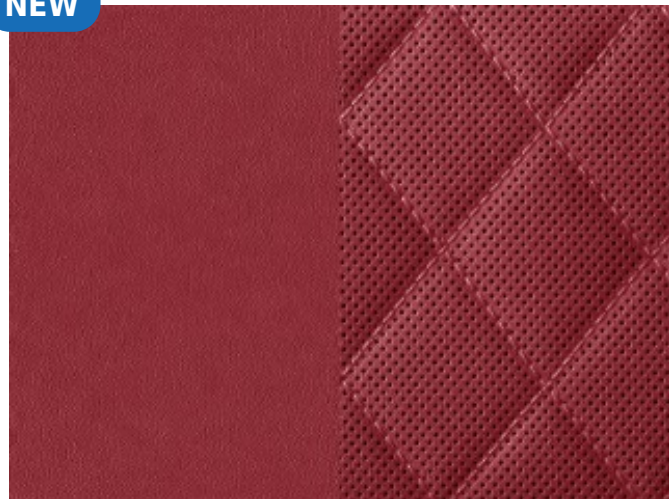

501 - Black

Requires 61U (Black DINAMICA) or 68U (Grey DINAMICA) Headliner, Requires P34 (Exclusive Upholstery) and 735

504 - Exclusive Sienna Brown & Black

Requires 61U (Black DINAMICA) Headliner, Requires P34 (Exclusive Upholstery) and 735

505 - Exclusive Macchiato & Magma Grey/ Comes with Magma Grey Floor/FloorMats

Requires 65U (Beige DINAMICA) Headliner, Requires P34 (Exclusive Upholstery) and 735

507 - Exclusive Carmine Red & Black

Requires 61U (Black DINAMICA) Headliner, Requires P34 (Exclusive Upholstery) and 735

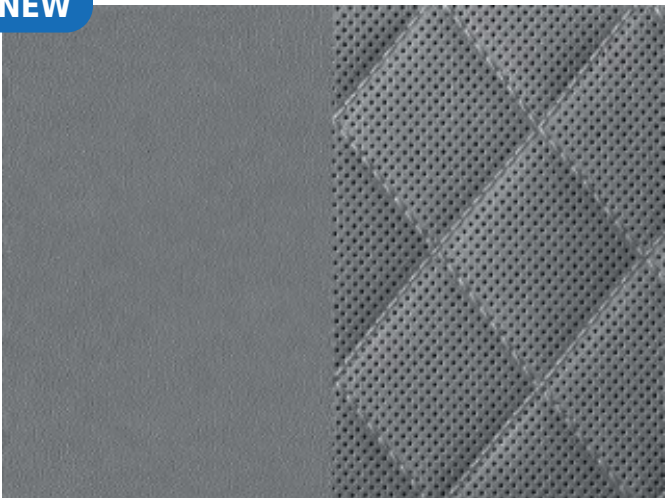

NEW

508 - Exclusive Silver Grey & Black

Requires 61U (Black DINAMICA) or 68U (Grey DINAMICA) Headliner, Requires P34 (Exclusive Upholstery) and 735



<i>Code</i>	<i>Description</i>	<i>Availability</i>	<i>Price</i>
801	Black Requires 51U Black Headliner or 58U Grey Headliner	S580V4	\$0
804 (New)	Sienna Brown & Black Requires 51U Black Headliner	S580V4	\$0
805 (New)	Macchiato & Magma Grey Requires 55U Beige Headliner/Comes with Magma Grey Floor/FloorMats	S580V4	\$0
501	Black Requires 61U (Black DINAMICA) or 68U (Grey DINAMICA) Headliner, Requires P34 (Exclusive Upholstery) and 735	S580V4	
504 (New)	Exclusive Sienna Brown & Black Requires 61U (Black DINAMICA) Headliner, Requires P34 (Exclusive Upholstery) and 735	S580V4	
505 (New)	Exclusive Macchiato & Magma Grey/ Comes with Magma Grey Floor/FloorMats Requires 65U (Beige DINAMICA) Headliner, Requires P34 (Exclusive Upholstery) and 735	S580V4	
507 (New)	Exclusive Carmine Red & Black Requires 61U (Black DINAMICA) Headliner, Requires P34 (Exclusive Upholstery) and 735	S580V4	
508 (New)	Exclusive Silver Grey & Black Requires 61U (Black DINAMICA) or 68U (Grey DINAMICA) Headliner, Requires P34 (Exclusive Upholstery) and 735	S580V4	

<i>Code</i>	<i>Upholstery</i>	<i>Seats</i>	<i>Floor Mats</i>	<i>Upper Dash/Lower Dash</i>	<i>Seat Belts</i>	<i>Steering Wheel</i>	<i>Headliner</i>
801	Black Requires 51U Black Headliner or 58U Grey Headliner	Black	Black	Black	Black	Black	Black or Grey
804 (New)	Sienna Brown & Black Requires 51U Black Headliner	Sienna Brown	Black	Black	Black	Black	Black
805 (New)	Macchiato & Magma Grey Requires 55U Beige Headliner/Comes with Magma Grey Floor/FloorMats	Macchiato	Magma Grey	Magma Grey	Macchiato	Macchiato	Beige
501	Black Requires 61U (Black DINAMICA) or 68U (Grey DINAMICA) Headliner, Requires P34 (Exclusive Upholstery) and 735	Black	Black	Black	Black	Black	Black or Grey
504 (New)	Exclusive Sienna Brown & Black Requires 61U (Black DINAMICA) Headliner, Requires P34 (Exclusive Upholstery) and 735	Sienna Brown	Black	Black	Black	Black	Black
505 (New)	Exclusive Macchiato & Magma Grey/ Comes with Magma Grey Floor/FloorMats Requires 65U (Beige DINAMICA) Headliner, Requires P34 (Exclusive Upholstery) and 735	Macchiato	Magma Grey	Magma Grey	Macchiato	Beige	Beige
507 (New)	Exclusive Carmine Red & Black Requires 61U (Black DINAMICA) Headliner, Requires P34 (Exclusive Upholstery) and 735	Carmine Red	Black	Black	Black	Black	Black
508 (New)	Exclusive Silver Grey & Black Requires 61U (Black DINAMICA) or 68U (Grey DINAMICA) Headliner, Requires P34 (Exclusive Upholstery) and 735	Silver Grey	Black	Silver Grey	Black	Black	Black or Silver Grey



Trims

NEW **DELAYED**

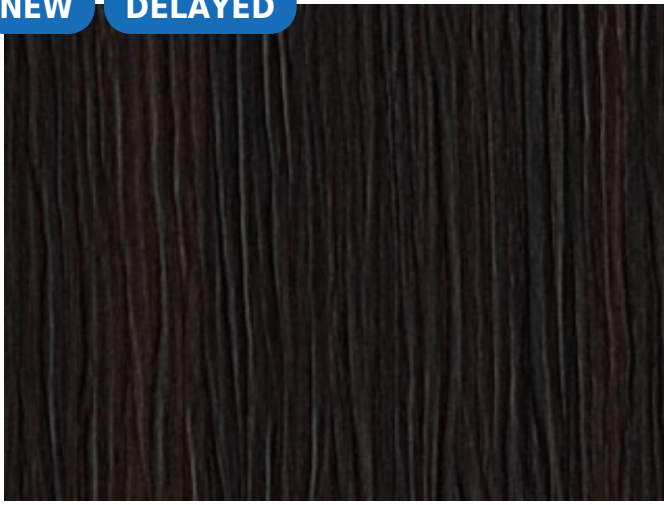

H02 - Finline “Anthracite” Natural Grain

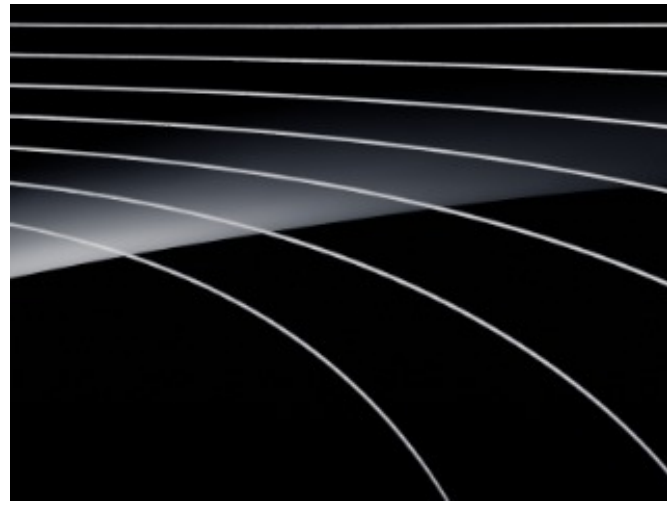

H17 - Piano Lacquer Flowing Lines

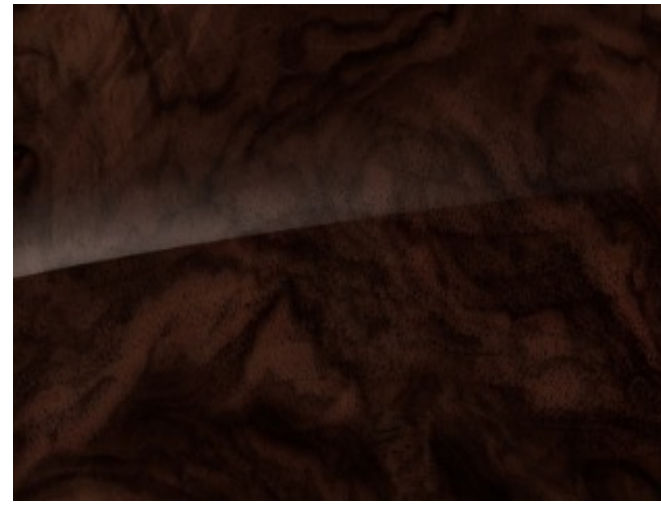

H29 - Brown High-Gloss Burl Walnut Wood

Not available with AMG Line (DX1)



H37 - Slate High-Gloss Poplar Wood

NEW **DELAYED**

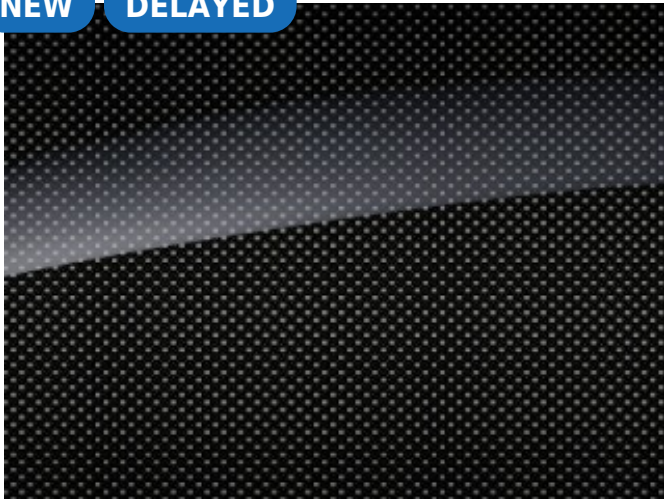

H75 - Stainless Steel-Metal Blended Black/Silver

Only available with AMG Line (DX1)

NEW **DELAYED**

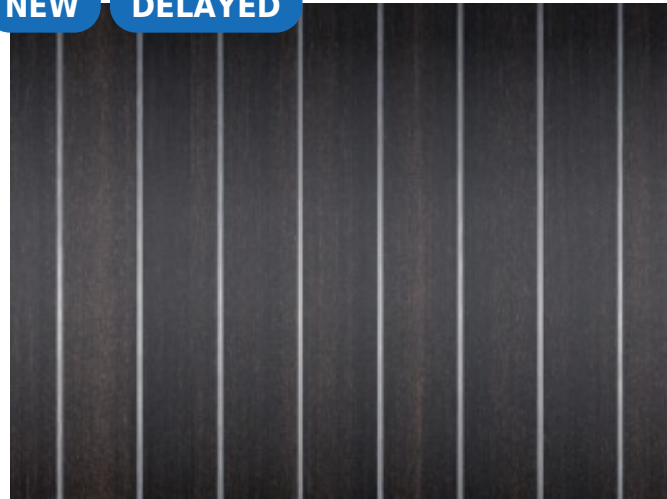

H38 - Silver Aluminum Fanned Walnut Wood

Delayed Availability

<i>Code</i>	<i>Description</i>	<i>Availability</i>	<i>Price</i>
H02 (New)	Finline “Anthracite” Natural Grain	S580V4	\$0
H17	Piano Lacquer Flowing Lines	S580V4	
H29	Brown High-Gloss Burl Walnut Wood Not available with AMG Line (DX1)	S580V4	\$0
H37	Slate High-Gloss Poplar Wood	S580V4	\$0
H75 (New)	Stainless Steel-Metal Blended Black/Silver Only available with AMG Line (DX1)	S580V4	
H38 (New)	Silver Aluminum Fanned Walnut Wood Delayed Availability	S580V4	



Packages

<i>Code</i>	<i>Packages</i>	<i>Availability</i>	<i>MSRP</i>
DX0 (New)	Luxury Line <ul style="list-style-type: none"> ▪ 436 - Front Comfort Headrests ▪ 72B - USB Package plus ▪ 878 - Active Ambient Lighting ▪ 432 - Active Multi contour Seats ▪ 943 - Toll Gate Transponder ▪ 401 - Ventilated Front Seats ▪ 297 - Electric Sunblinds in Rear Doors ▪ 501 - 360 Surround View Camera ▪ 902 - Front Heated Seat Plus ▪ P21 - Air Balance Package 	S580V4	
DX1 (New)	AMG Line All Standard Equipment from Luxury Line Plus <ul style="list-style-type: none"> ▪ U26 - AMG Floor mats ▪ WCO - Wheel Choice of: <ul style="list-style-type: none"> ○ RWK - 21" AMG V-Multispoke Wheels ○ RVR - 20" AMG Multispoke Wheels with Black Inlays /Only with Night Package (DC1) ○ RVQ - 20" AMG Multispoke Wheels ○ RZI - 19" AMG Twin 5-Spoke Wheels ○ RWN - 21" AMG V-Multispoke Wheels with Black Inlays / Only with Night Package (DC1) ▪ 951 - Sport Package Code ▪ 772 - AMG Line Exterior 	S580V4	
DX2 (New)	Executive Line All Standard Equipment from Luxury Line Plus <ul style="list-style-type: none"> ▪ 453 - Executive Rear Seat ▪ 854 - MBUX High-End Rear Entertainment ▪ 898 - Wireless Charging Rear ▪ 452 - Electric Adjust Rear Seats ▪ P43 - Rear Seat Comfort ▪ 439 - Easy Adjust Headrest ▪ 402 - Ventilated Rear Seats ▪ 276 - Rear Memory Seats ▪ P07 - Chauffeur Package Rear ▪ 906 - Front Heated Armrest ▪ 322 - Rear Neck Heating ▪ U58 - 2 Wireless Headsets ▪ 216 - 10 Degree Rear Axle Steering ▪ 447 - MBUX Rear Tablet ▪ 907 - Rear Heated Armrest ▪ 561 - Design Belt Buckles Rear ▪ 735 - Exclusive Trim ▪ 443 - Heated Steering Wheel ▪ 306 - Rear Beltbag ▪ 903 - Rear Seat Heating ▪ 223 - Power Rear Seats ▪ 302 - Rear Airbag ▪ PBT - Rear ENERGIZING COMFORT Package ▪ PBS - Front ENERGIZING COMFORT Package ▪ 582 - 4-Zone Climate Control ▪ 406 - Active Multicountour Rear Seats 	S580V4	
DB0	Warmth and Comfort Package Available with Luxury and AMG Line. Standard for Executive Line <ul style="list-style-type: none"> ▪ 907 - Heated Rear Armrests ▪ 223 - Power Rear Seats ▪ 443 - Heated Steering Wheel ▪ 402 - Heated and Ventilated Rear Seats ▪ 276 - Memory Rear Seats ▪ 906 - Heated Front Armrests 	S580V4	
DF0 (New)	3D Technology Package Code Available with Luxury, AMG and Executive Line <ul style="list-style-type: none"> ▪ 445 - MBUX Augmented Reality Head-Up Display ▪ 451 - 3D Instrument Cluster 	S580V4	
DC1 (New)	Night Package Only available with AMG Line <ul style="list-style-type: none"> ▪ P55 - Night Package Code 	S580V4	



Options

Factory Options

<i>Code</i>	<i>Options</i>	<i>Availability MSRP</i>
201 (New)	4.5 Degree Rear Axle Steering Available on AMG Line (DX1)	S580V4
443	Heated Steering Wheel Available on Luxury (DX0) and AMG (DX1) Line	S580V4
735	Exclusive Trim Available on Luxury (DX0) and AMG (DX1) Line/Standard on Executive (DX2) Line - Additional Wood Trim in Front and Rear Doors, Seat Backrests and Rear Air Vent Cover	S580V4
811 (New)	Burmester® High-End 4D Surround Sound System Available on Luxury (DX0), AMG (DX1) and Executive (DX2) Line	S580V4



VPC Installed Options

<i>Code</i>	<i>Options</i>	<i>Availability</i>	<i>MSRP</i>
D07	Wheel Locks	S580V4	
D10	Rear Spoiler	S580V4	
D21	Rear Spoiler - Black	S580V4	
D28	Comfort Box	S580V4	
D33	All-Season Front Floor Mats, Black Rubber	S580V4	



Specifications

S500V4



Drivetrain

Transmission	9G-TRONIC 9-Speed Automatic Transmission
Drive Configuration	All-wheel Drive

Engine

Engine Configuration	4.0L V8 Biturbo engine with EQ-Boost
ICE Power (hp)	496 hp
Torque (lb-ft)	516 lb-ft
Compression Ratio	TBD
Fuel Requirement (Octane)	TBD
Fuel Tank Size (gallons)	22.19
Displacement (cc)	3982

Performance

Acceleration 0-60pmg (sec)	TBD
Top Speed (mph)	130
Transmission Speeds	9
Towing Capacity (lbs)	TBD
Maximum Load	TBD

Fuel Economy

City Fuel Economy	TBD
Highway Fuel Economy	TBD
Emission Certification	TBD

Exterior Dimensions

Vehicle Length (in.)	208.2
Vehicle Height (in.)	59.2
Vehicle Width w/ exterior mirrors (in.)	83.0
Wheelbase (in.)	126.6
Curb Weight (lbs)	TBD
Track Width Front/Rear (in.)	TBD

Interior Dimensions

Trunk Size (cubic feet)	12.9
-------------------------	------

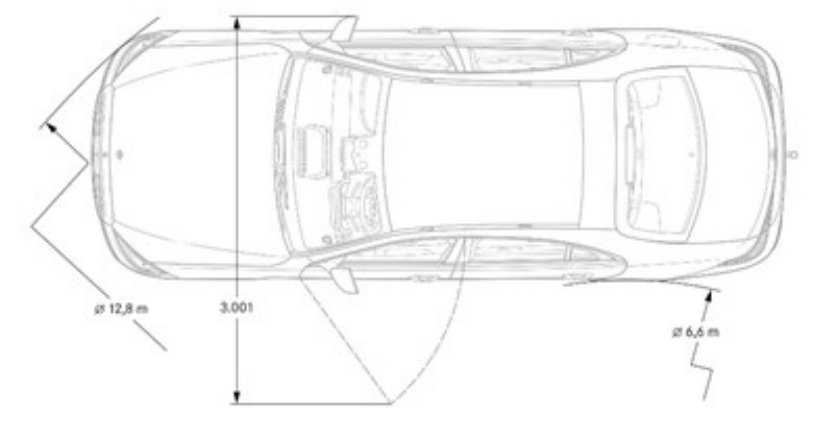
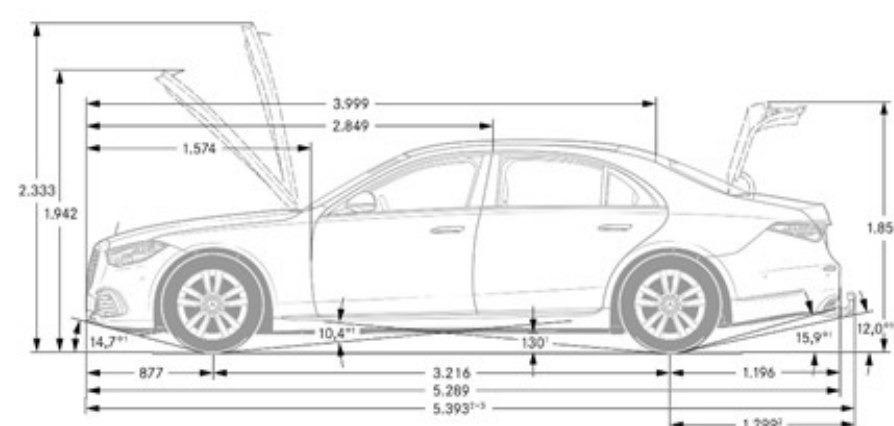
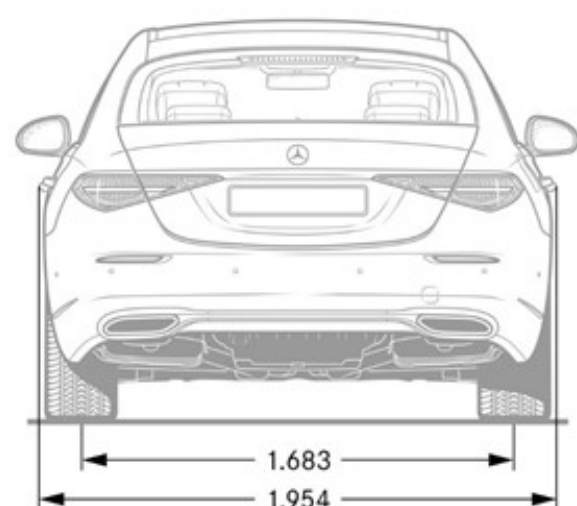
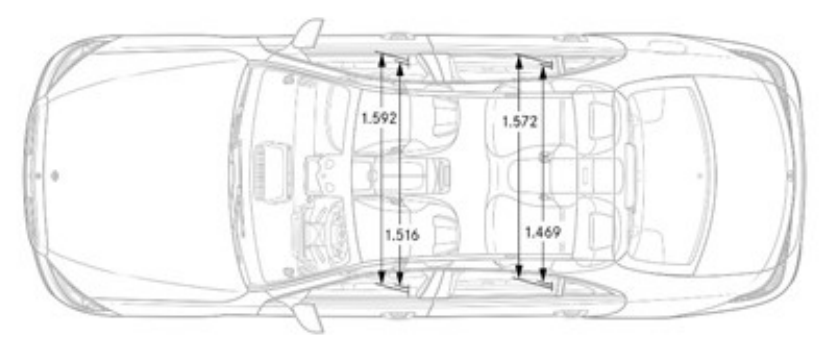
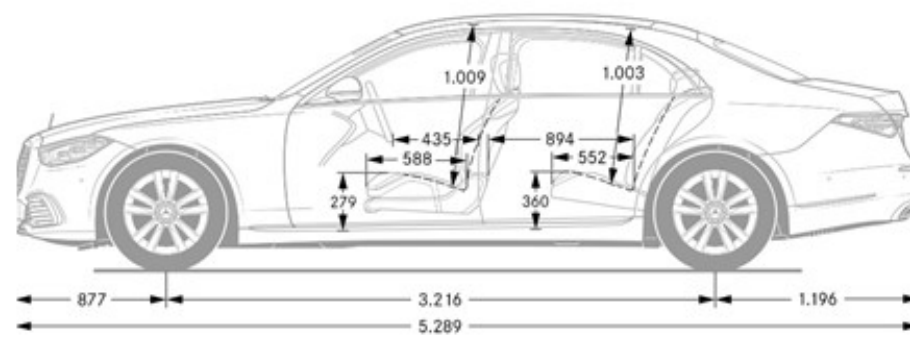
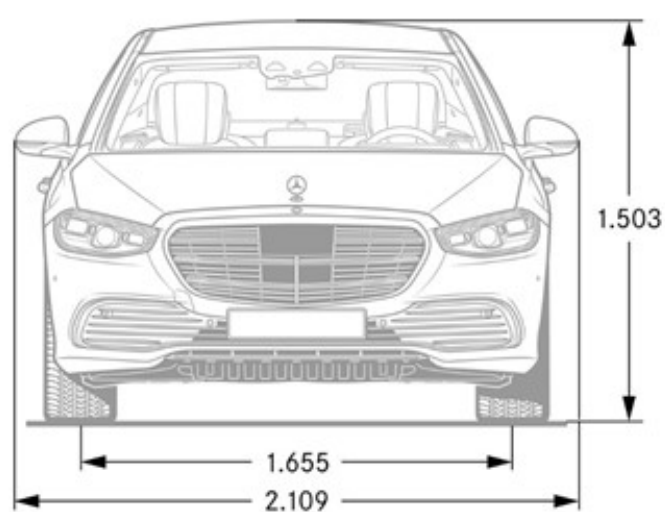

Options In Detail

Steering Wheel



3-spoke Nappa Leather Steering Wheel (L2B)

Standard

- 3-Spoke Steering Wheel
- Spokes in high-gloss black with silver chrome surround
- Steering wheel paddle shifters in silver chrome
- Operation via Touch Control panels:
 - Left: e.g. instrument cluster, Active Distance Assist DISTRONIC
 - Right: multimedia system (e.g. audio volume and title selection, telephony and navigation)
 - Touch sensitivity adjustable via central display



3-spoke Wood & Leather Steering Wheel (L2D)

Standard

Not with Fineline Anthracite Natural Grain (H02), Silver Aluminum Fanned Walnut (H38)

- 3-Spoke Steering Wheel
- Spokes in high-gloss black with silver chrome surround
- Steering wheel paddle shifters in silver chrome
- Operation via Touch Control panels:
 - Left: e.g. instrument cluster, Active Distance Assist DISTRONIC
 - Right: multimedia system (e.g. audio volume and title selection, telephony and navigation)
 - Touch sensitivity adjustable via central display





Burmester® High-End 4D Surround Sound System (811) (Optional)

Optional with Luxury, AMG and Executive Line

You enjoy music with all of the senses and get a unique 4D experience. This new dimension comes courtesy of speaker-like resonators featuring sound massage. Surround speakers integrated into the seats also help to optimize the surround sound. Furthermore, the clear voice reproduction delivered by the telephony ensures you benefit from a perfect workspace.

Key Facts:

- Amplifier with digital and analogue filters and output of 1750 watts for natural, warm and at the same time solid sound
- 30 high-end speakers, all with their own amplifier channel
- Additional amplifier with an output of 400 watts for subwoofer bass speaker (18.5-litre volume) in the boot
- 2 broadband speakers in the upper backrest area of each front seat, their position close to the ear also optimizes the quality of telephony (Driver Mode)
- 6 broadband speakers (3D-Sound) distributed in the overhead control panel, the roof cluster between the front and rear seat row and also in the sides behind the B-pillars
- 2 resonators each per front seat and outer rear seats (technically like a speaker without a membrane) in the seat backrests, vibrate and pulsate in synch with the music
- 2 bass speakers integrated in the bodyshell (Frontbass technology)
- 1 subwoofer in each door
- 7 mid-range speakers (one in each door, one centrally on the dashboard, two on the parcel shelf)
- 7 tweeters (in the front in the mirror triangle - integrated and extending, combined with ambient lighting - one in each of the rear doors, one centrally on the dashboard, two on the parcel shelf)
- Sound Personalization function for sound reproduction tuned to individual music tastes
- VIP seat function to optimize the sound for individual seats
- 5 sound profiles: Pure, Live, Easy Listening, Surround, 3D-Sound
- Noise compensation (VNC)
- Supports multichannel audio formats
- 2-way in-car communication

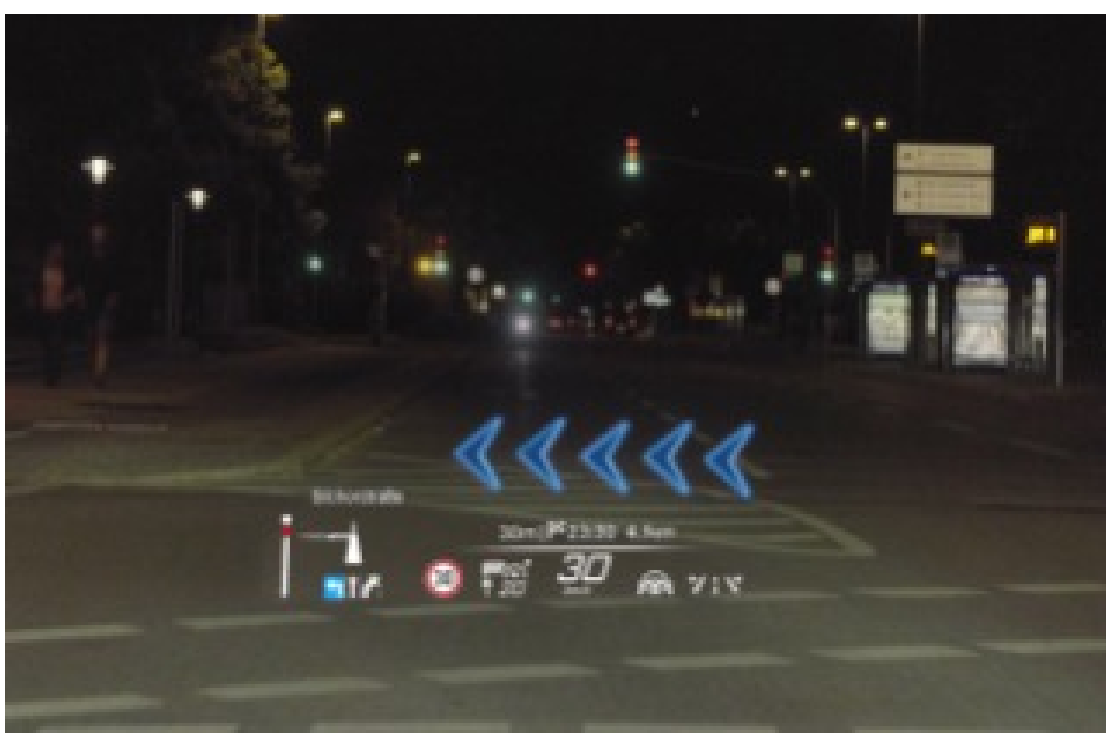

3D Technology Package- Augmented Reality Head-UP Display-(DF0) (Optional)

Optional with Luxury, AMG and Executive Line

The latest projector technology projects a virtual image with relevant information into your field of vision. The display area is very much larger compared to a classic head-up display. Colorful, superimposed content appears at a virtual distance of 32.8 feet ahead of the vehicle. This directly perceptible information blends seamlessly with reality. It provides real added value, especially in complex situations where you need to make a turn. When you arrive, your destination is marked prominently with the street name and house number.

If desired, the MBUX augmented reality head-up display can also show reports from Active Distance Assist DISTRONIC. You can quickly switch between navigation or driving assistance systems with swiping movements on the left touch switch panel.

Even on bright, sunny days and on light-coloured road surfaces, you can clearly see the information of the head-up display. To this end a sensor automatically adapts the brightness to the ambient light.

- Projects virtual colorful images into the driver's field of vision 32.8 feet ahead of the vehicle
- Large display measuring 1750 x 873 millimetres
- Supports navigation functions with:
 - Direction arrows and lane change recommendations
 - Display of street names, house numbers and – if route guidance is active – points of interest
 - Alternatively visualisation of driving assistance systems with distance information from Active Distance Assist DISTRONIC
 - Automatic position adjustment for different drivers using the cameras in the 3D driver display



3D Technology Package- 3D Instrument Cluster- (DF0) (Optional)

Optional with Luxury, AMG and Executive Line

Keep your eye on the important things in the 3D instrument cluster. The three-dimensional warnings and functions of the driving assistance systems are immediately noticeable with their striking 3D and shaded effects. Another trailblazing effect is the fascinating 3D image of cars, trucks, buses or motorcycles ahead of your vehicle.

Key Facts:

- Free-standing 12.3-inch (31.2 cm) display with resolution of 2400 x 2 x 900 pixels
- Controlled via the left touch switch panel or MBUX voice assistant
- 3D display with spatial/shading effects for
 - other road users (cars, trucks, buses, motorcycles)
 - Navigation instructions
 - Functions of the driving assistance systems
 - Vehicle information
- Different display styles such as "Modern Classic" and "Luxury", also "Discreet" with reduced display content
- Full-screen mode for navigation (including zoom function) and for driving assistance
- Extension of ATTENTION ASSIST with microsleep warning using a driver camera:
 - Registers driver characteristics such as facial expression and eyelid movement
 - Recognizes distraction and drowsiness
 - Visual and acoustic warning signal
 - Automatic calibration
 - Active from a speed of 12 MPH
 - Independent of the outside light level



Rear Passenger Airbag (302)

Included in Executive Line (DX2) Only

Innovative air cushions make your rear passenger compartment even safer. The rear airbags are integrated into the backrests of the front seats and deploy in a severe front impact. They unfold gently and protect strapped-in outer rear seat passengers against contact with the seats. This reduces the load on the head and neck significantly.

For this, gas stored under pressure inflates cylindrical tubes. They form the outer framework. Ambient air fills the space in between via patented valves and remains enclosed there. This creates an airbag cushion into which the passengers are immersed.

This concept takes into account the adjustable front seat backrests, the space conditions in the rear plus the different seating positions of adults or children. The tubular wings avoid obstacles such as child seats, enabling the load to be channeled past them.

Key Facts:

- One airbag each in the front seat backrests, deploy in the event of a severe front impact
- Innovative deployment and inflation concept – outer tube structures inflated by compressed gas and an airbag in between filled with compressed ambient air
- Stabilizes strapped-in outer rear seat passengers and can protect them against a possible impact with the front seats, loads on head and neck can be reduced significantly
- Gentle deployment of the airbag and thus reduced risk of injury – channels the tube structure past obstacles such as child seats, thus reducing the effect of the force



4.5° Rear-Axle Steering

Optional 4.5° with AMG Line (DX1)

The rear-axle steering with steering angle adjustment of 4.5° offers three key advantages: even more superior roadholding, significantly enhanced agility and, last but not least, better manoeuvrability – such as when parking. For this, the rear wheels steer in the opposite or the same direction as the front wheels depending on the vehicle speed.

- Four speed-dependent steering strategies:
 - Parking with a reduced turning circle (steering angle of up to 4.5° in the opposite direction to the front axle)
 - City manoeuvrability (steering angle of up to 4.5° in the opposite direction to the front axle), active up to approx. 60 km/h
 - Top speed stabilisation (steering angle of up to 2.5° in the same direction as the front axle)
 - Increase in driving dynamics (steering angle of up to 3° in the same direction as or opposite direction to the front axle depending on driving situation), active from approx. 60 km/h, controlled by the dynamic handling control system integrated into the ESP®
- Snow chain mode for adapted actuation of the rear axle steering in wintry conditions
- Representation of the rear axle steering in the central display
 - Display of the current rear axle steering angle
 - Overlay of current track circle when parking
- Rear axle steered via an electromechanical central actuator with trapezoidal screw thread

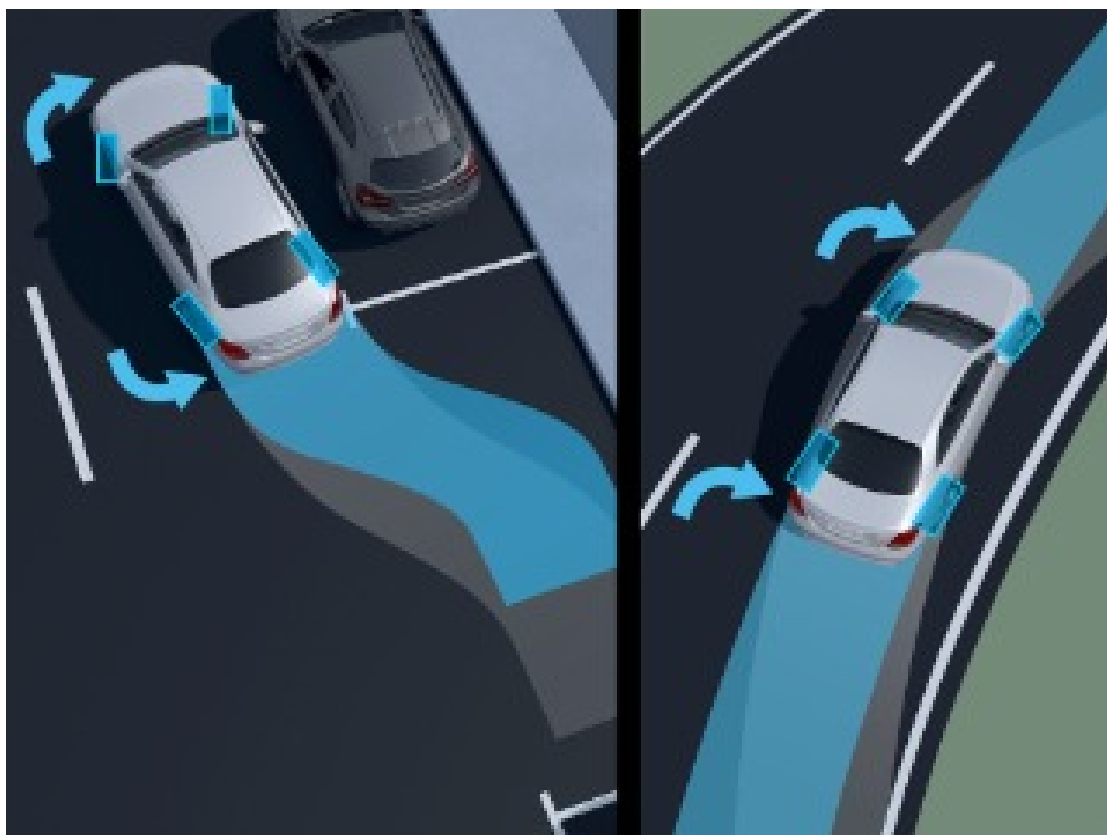

10° Rear-Axle Steering

Included with Executive Line only (DX2)

Experience the claim to leadership of Mercedes-Benz even when parking: this rear axle steering adjusts the steering angle by up to 10° and reduces the turning circle by almost two metres. As such your S-Class almost handles like a compact car when manoeuvring. At higher speeds, on the other hand, you drive with the effortless superiority afforded by the long wheelbase.

- Speed-dependent steering strategies:
 - Parking with a more reduced turning circle (steering angle of up to 10° in the opposite direction to the front axle) by almost two metres
 - City manoeuvrability (steering angle of up to 4.5° in the opposite direction to the front axle), active up to approx. 60 km/h
 - Top speed stabilisation (steering angle of up to 2.5° in the same direction as the front axle)
 - Increase in driving dynamics (steering angle of up to 3° in the same direction as or opposite direction to the front axle depending on driving situation), active from approx. 60 km/h, controlled by the dynamic handling control system integrated into the ESP®
- Snow chain mode for adjusted actuation of the rear axle steering in wintry conditions with a maximum rear axle steering angle of 4.5°
- Showcasing of the rear axle steering in the central display
 - Display of the current rear axle steering angle
 - Overlay of current track circle when parking
- Rear axle steered via an electromechanical central actuator with trapezoidal screw thread



Night Package DC1

Only Available with AMG Line (DX1)

With the Night Package your sporty exterior looks even more expressive. As part of this numerous elements are retained in high-gloss black. Depending on the paint finish, this creates contrasts or flowing transitions. In each case your vehicle gains individuality.

Components

- Front Splitter and Fins in the Air Intakes in High-Gloss Black
- Flared Side Sill Panels with Insert in High-Gloss Black
- Trim Element on the Rear Apron in High-Gloss Black
- Exterior Mirror Housings in High-Gloss Black



Build Recommendations



Gallery

All

Exterior

Interior

