

13-3420 Removing and installing poly V-belt

Preceding work:
Open hood, raise to vertical position (01-0080).

Operation no. of operation texts and work units or standard texts
and flat rates
13-1202 - 13-4001

1st version

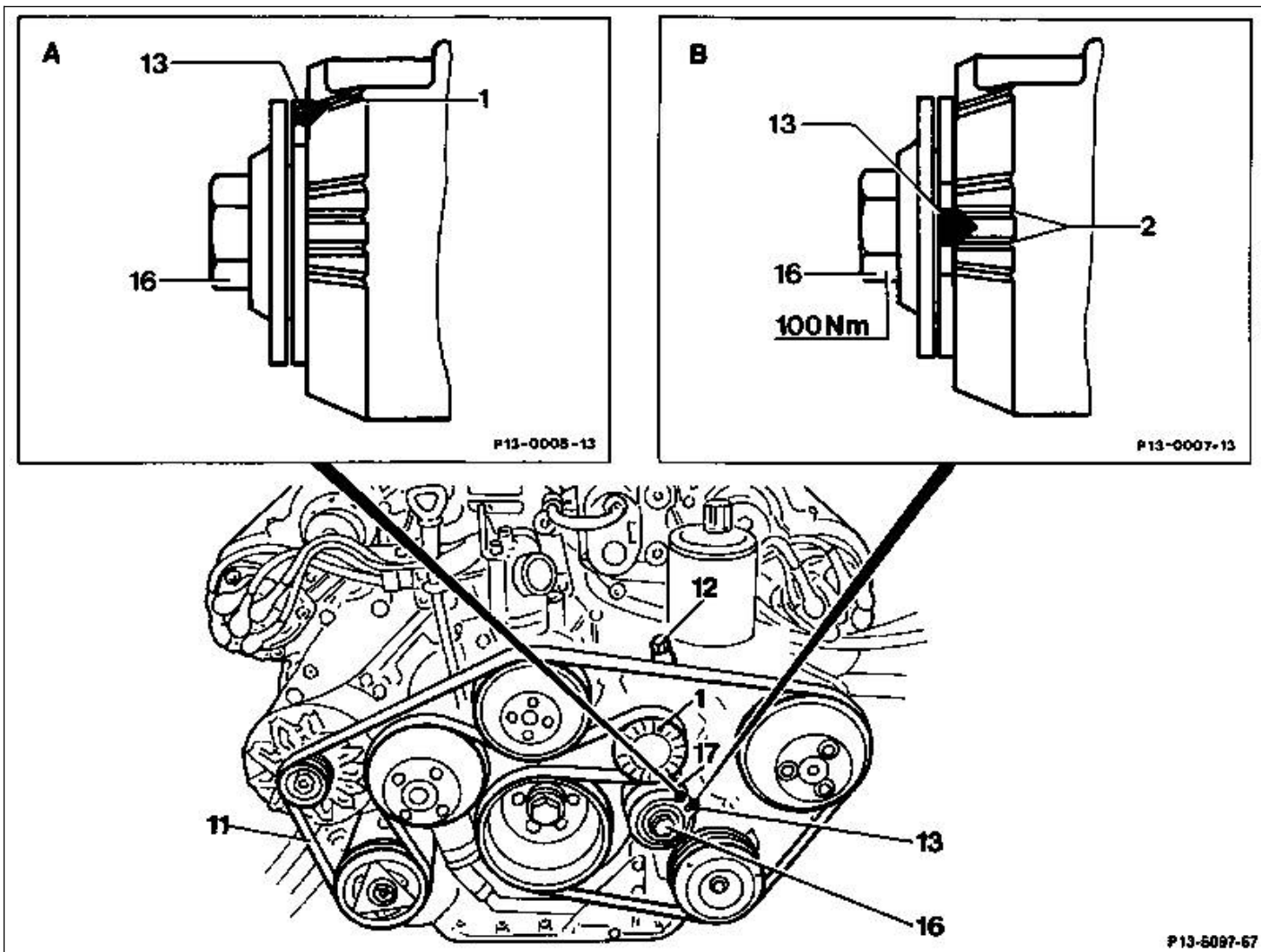

Motor 119.960

- A Setting pointer (13) to marking (1) = poly V-belt slackened
- B setting pointer (13) to marking (2) = poly V-belt slackened

Model 124: fan shroud..... remove, install.
Models 129, 140: fan shroud ring..... take off, place over fan, fit on.

Bolt (16).....	slacken about 1/4 - 1/2 turns.
Tensioning nut (5).....	slacken (turn to the left).
Poly V-belt.....	take off.
Belt pulley surfaces.....	examine for signs of damage and dirt, replace if necessary (e. g. worn bearing points of tensioning device, dents in belt pulleys etc.).
Setting pointer (13).....	turn to marking (1).
Poly V-belt.....	fit on, starting at tensioning pulley (1) (see 13-3440 for running diagrams).
	
	Do not use belt wax or similar products.
Tensioning nut (12).....	tighten until setting pointer (13) is located between the markings (2).
Bolt (16).....	tighten (100 Nm).
Seat of belt on belt pulleys.....	examine.

2nd and 3rd version

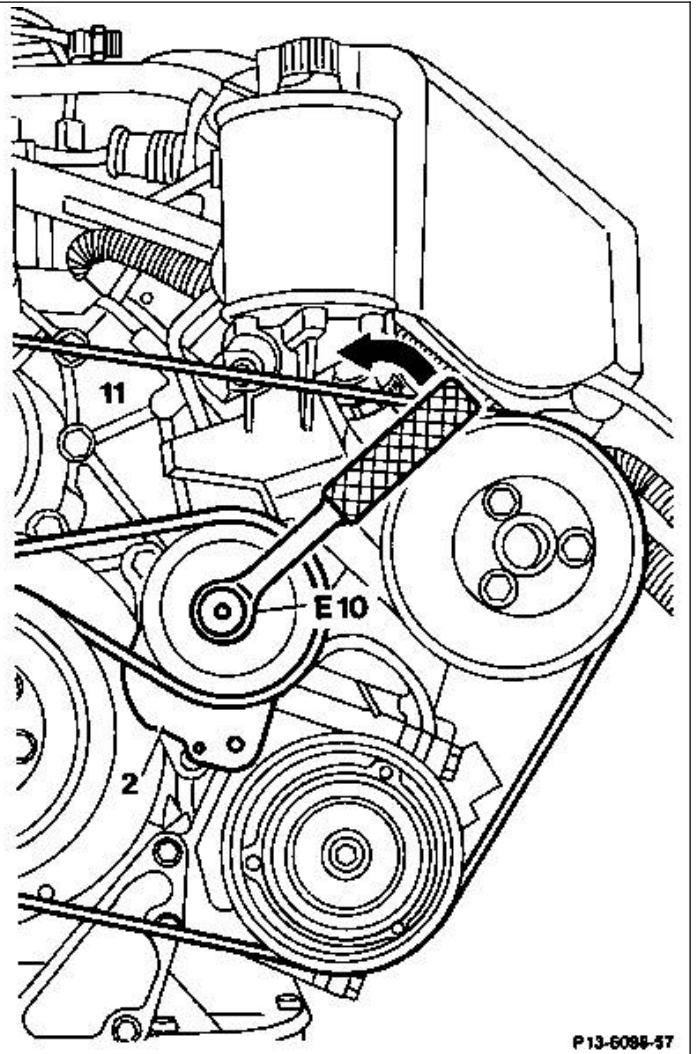
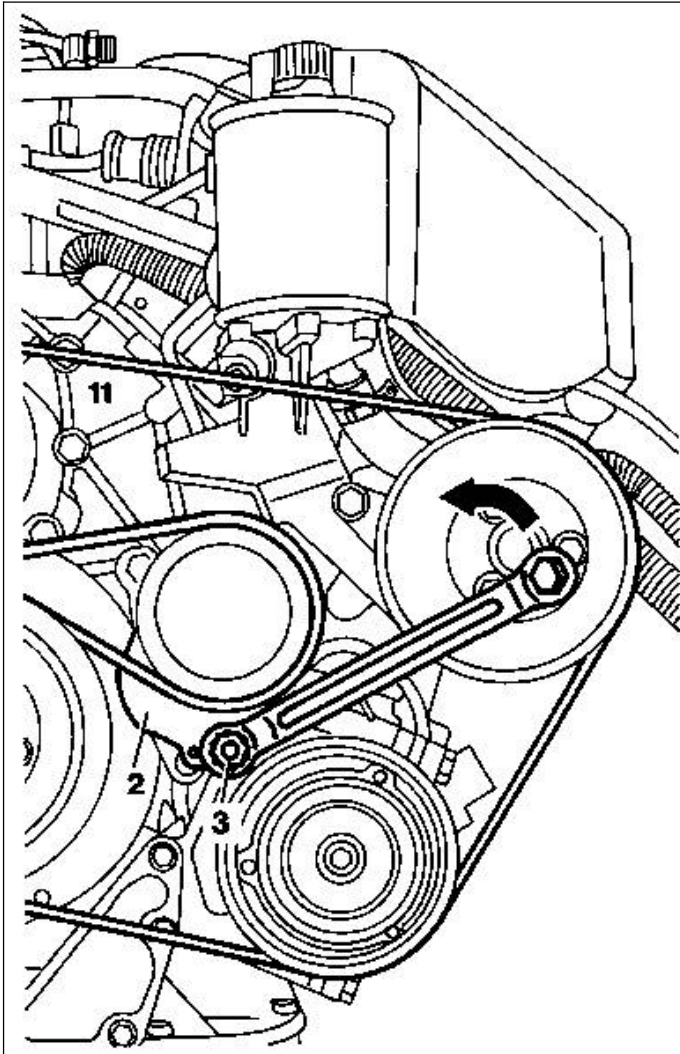

P 13-6088-17

2nd version

3rd version

Model 124: fan shroud.....	remove, install.
Models 129, 140: fan shroud ring.....	take off, place over fan, fit on.
2nd version: hexagon head (3) on tensioning arm (2).....	swivel counter-clockwise with wrench (WAF 17).
3rd version: Torx (E10) in tensioning pulley.....	swivel counter-clockwise.
Poly V-belt (11).....	take off.
Belt pulley surfaces.....	examine for signs of damage and dirt, replace if necessary (e. g. worn bearing points of tensioning device, dents in belt pulleys etc.).
Poly V-belt (11).....	fit on (running diagrams see 13-3440).
Seat of belt on belt pulleys.....	<p>⚠</p> Do not use belt wax or similar products. examine.

Special tool

(Tensioning device 1st version)

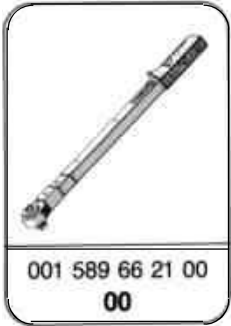

Special tool

(Tensioning device 3rd version)

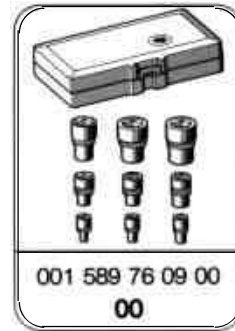

Tightening torque in Nm

Bolt (16) of tensioning device (tensioning device 1st version)

100
