



Installation instructions

Lumbar support for front seat

91.16

Model 129

These installation instructions are divided into the following sections:

- A. General work
- B. Procedure
- C. Parts ordering note

A. General work

At the customer's request, the orthopaedic lumbar support on the driver and front passenger backrest controlled by means of a hand-operated pump, can also be installed at a low cost. The single air cushion from the model 140 is installed between the cushion frame and cushion support.

The level of lumbar support can be individually controlled by means of the hand-operated pump which is always located centrally in the vehicle.

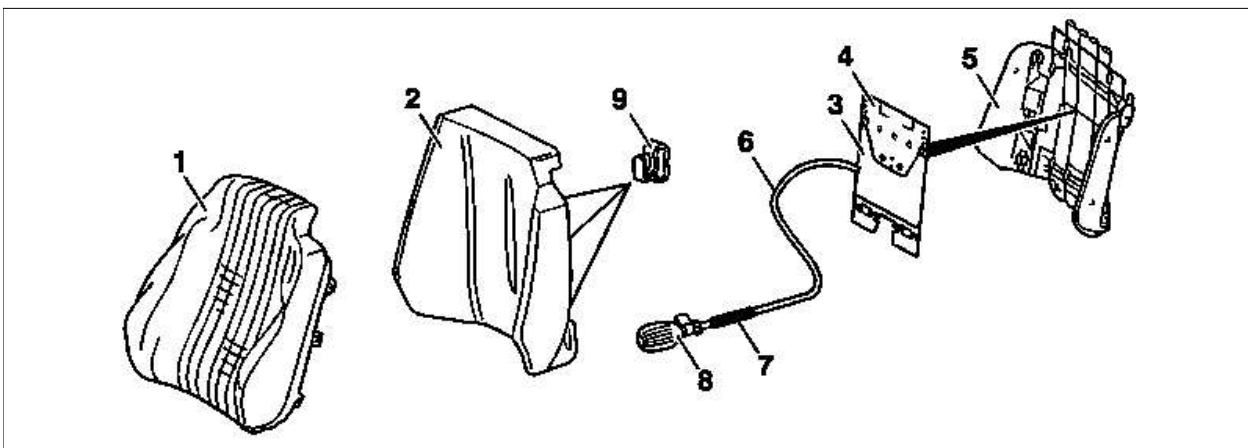

P91.25-0213-04

- | | | | |
|---|-------------------------|---|-------------|
| 1 | Seat cover | 6 | Pipe |
| 2 | Rubberized hair support | 7 | Rubber hose |

3	Air cushion	8	Hand-operated pump
4	Reinforcement plate	9	Longitudinal unhooking clip
5	Backrest frame		

B. Procedure

- 1 Removing and installing driver squab and backrest cushion (RA 91-055).
- 2 Unhook backrest cover (1) at the side and bottom of the backrest frame (5).
- 3 Unhook longitudinal unhooking clips (9) in the middle and at the bottom (4 off).
- 4 Pull out surround at the lower rubberized hair support (2).
- 5 Lift lower backrest frame (5) slightly off the rubberized hair support (2).
- 6 Push reinforcement plate (4) with air cushion (3) between rubberized hair support (2) and backrest frame (5) (air cushion points towards rubberized hair support and hose connection (6) towards the side of the seat belt buckle).
- 7 Align lumbar support, fix at the top and bottom to the spring clips to prevent it from slipping.
- 8 Put back surround on lower rubberized hair support.

- 9 Push in plug connections at the side for the seat heating system.
- 10 Lead vacuum pipe (6) at the side downwards out of the backrest frame (5).
- 11 Hook backrest cover (1) in the side and bottom on the backrest frame (5).
- 12 Hook in longitudinal unhooking clips (9) (4 off).
- 13 Install backrest cushion while paying attention to correct routing of the pipe (6).
- 14 Connect seat heating system.
- 15 Install driver squab.
- 16 Connect seat heating system.
- 17 Route pipe (6) between seat belt buckle and squab.
- 18 Connect hand-operated pump (8) to pipe (6) with rubber hose (7).

Note

Length of rubber hose in accordance with customer's requirements.

- 19 Store hand-operated pump (8) loose on the side, e.g. in the oddments tray of the center console or attach to the front fire extinguisher holder.
- 20 Check operation.

C. Parts ordering note

Quantity	Designation	Part number
1	Air cushion, left	140 910 01 75
1	Air cushion, right	140 910 02 75
1	Hand-operated pump	126 910 00 38
1	Air hose ¹⁾	007 997 61 82
1	Vacuum pipe ¹⁾	000 158 14 35

1) Length to suit customer requirements