

P20.40-0220-57

Cap with detent

Cap (5)..... turn anticlockwise to detent 1 to release pressure.



Cap (5) must not be opened unless coolant temperature is below 90 °C.

Risk of scalding!

Test cap (3) 124 589 00 91 00 attach to tester (2) 124 589 24 21 00, remove.

Double union (4) 124 589 53 63 00..... attach to tester (2) 124 589 24 21 00, remove.

Cap (5)..... attach to double union (4), remove.

Opening pressure of pressure relief valve..... test. See table for opening pressure.
 Vacuum valve..... test. Lift vacuum valve (6) for this step.

Note

The vacuum valve (6) must be making contact with the rubber seal of the sealing plate. It must be easy to lift and spring back when released.
 The contact surface for the sealing plate at the expansion reservoir must be flat.
 Replace cap which is corroded.
 The part no. and the cap code no. are stamped in the cap.

2-stage cap in model 210

Cap (5a)..... turn half a turn anticlockwise to release pressure.



Cap (5a) must not be opened unless coolant temperature is below 90 °C.
 Risk of scalding!

Adapter (3a) 210 589 03 63 00..... attach to tester (2) 124 589 24 21 00, remove.
 2-stage cap (5a)..... screw onto adapter (3a), remove. Pay attention to note.
 Opening pressure of pressure relief valve..... test. See table for opening pressure.

Note

The cap code numbers are stamped in the cap.
 See note for design of 2-stage cap.

Test data of cap with detent

Cap code number	Pressure relief valve opens at bar gauge		Vacuum valve opens at bar vacuum
	new	used	
140	1.4 ± 0.1	1.4 - 0.1	0.1

Test data of 2-stage cap

Cap code number	Pressure relief valve opens at bar gauge		Vacuum valve opens at bar vacuum
	1st stage	2nd stage	
140/200	1.4±0.1	2.0±0.1	0.1

Special tools

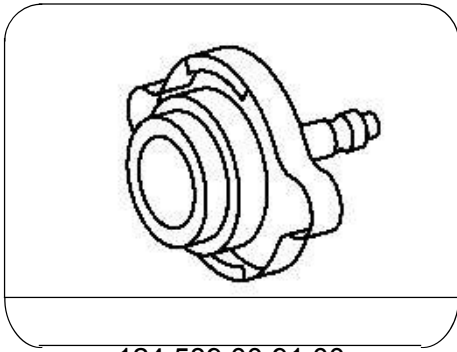

124 589 00 91 00

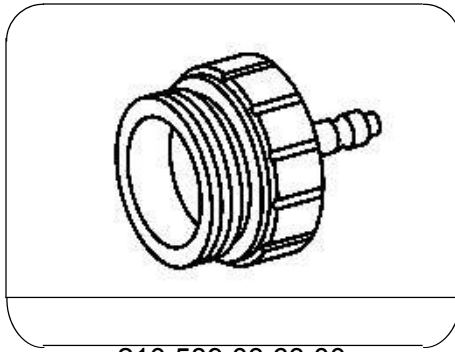

210 589 03 63 00

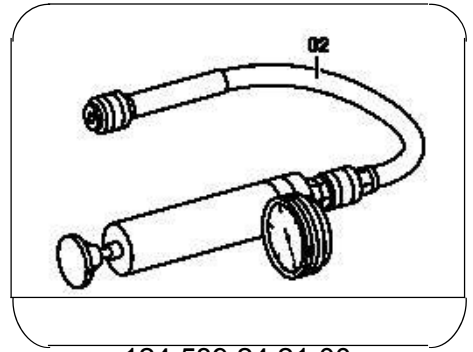

124 589 24 21 00

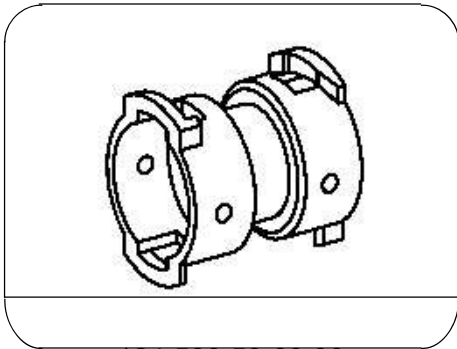

124 589 53 63 00

Note

A 2-stage cap is fitted to model 210.



The 2-stage cap must be screwed in sufficiently until the lug engages in the notch at the coolant expansion reservoir.

The cap has an additional pressure stage with the result that the system pressure may rise to 2 bar during the engine off heating phase without coolant flowing out.

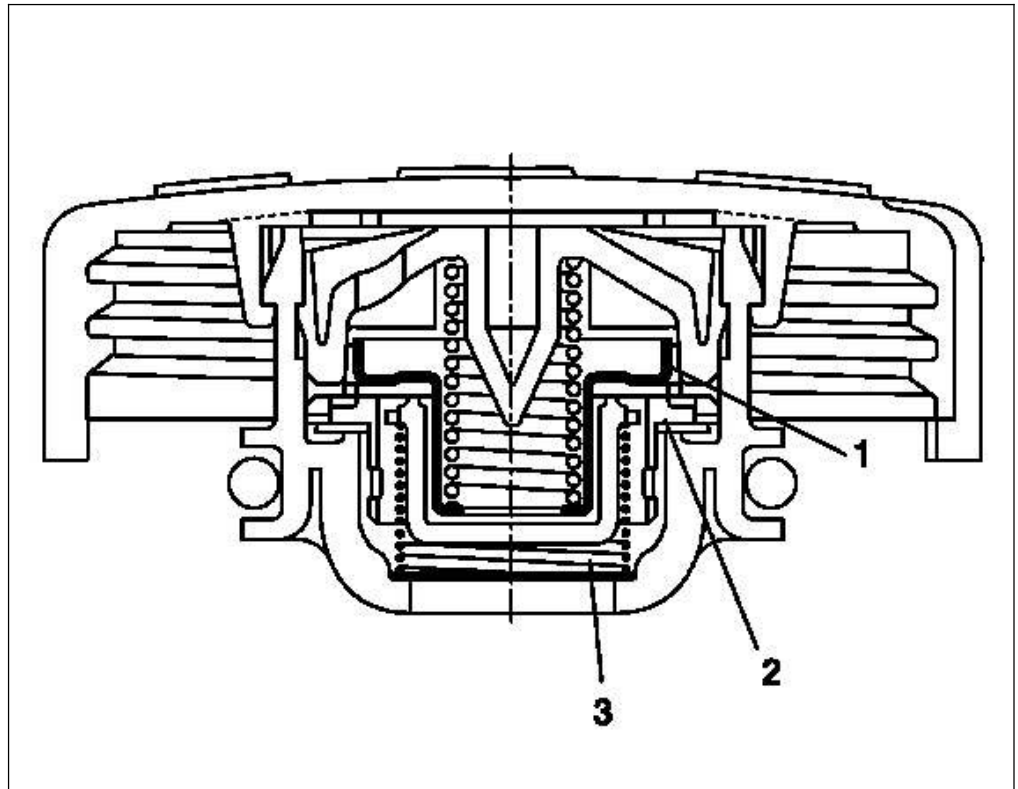

P20-5408-35