

P46-2266-13

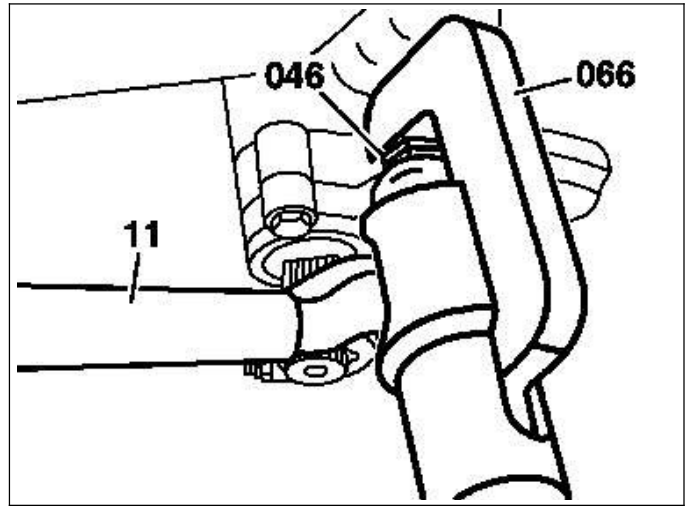

P46-2260-13

- Steering shock absorber..... Detach, attach at the drag link fixing (11), replace nut, 35-40 Nm.
- Nut (34) of drag link (11)..... Unscrew, screw on, replace.
 35 Nm -Model 124 up to 05/89 and 4MATIC
 50 Nm -Model 201
 -Model 124 as of 06/89
 -Model 124.034/036
- Thrust piece (046) 129 589 10 63 00 or 201 589 05 63 00 screw on, unscrew.

- Ball joint of drag link (11)..... press off from steering arms.
 ● Use puller 124 589 02 33 00 on model 124 as of 06/89 and 4MATIC
 ● Use puller 201 589 13 33 00 on Model 124 up to 05/89 (except for 4MATIC), Model 201
 When installing, clean grease off tapered connection and push in drag link securely.
- Check joint of drag link
 If there is play or the rubber boot is damaged, replace drag link. If the rubber boot was damaged when the drag link was removed, replace rubber boot (46-7202).

Special tools

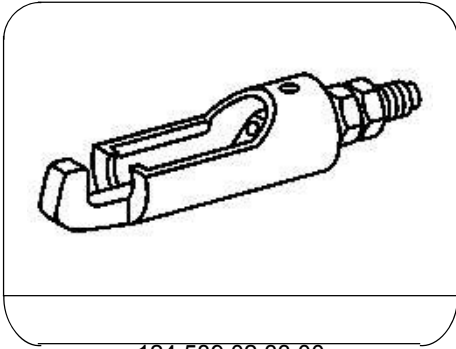

124 589 02 33 00

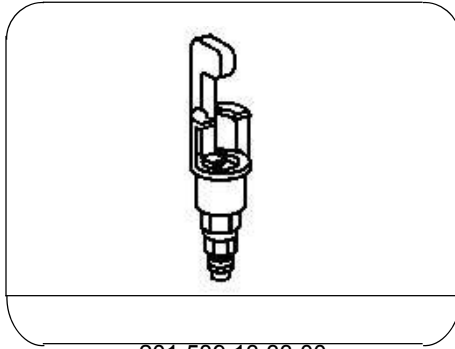

201 589 13 33 00

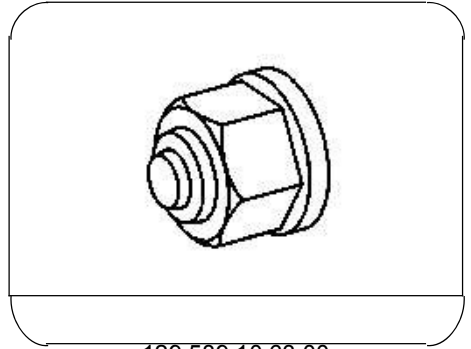

129 589 10 63 00

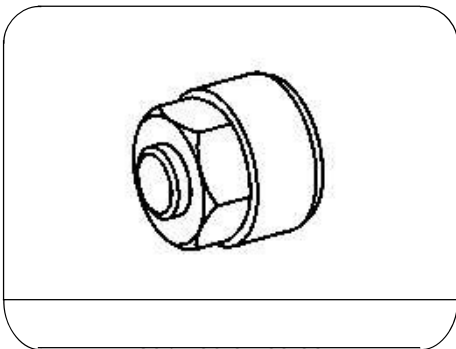

201 589 05 63 00

Notes

Since 06/89, a 10 mm shorter drag link which has been turned through 180° has been installed.

Drag link (A) with thread M10 up to 05/89
Drag link (B) with thread M12 as of 06/89

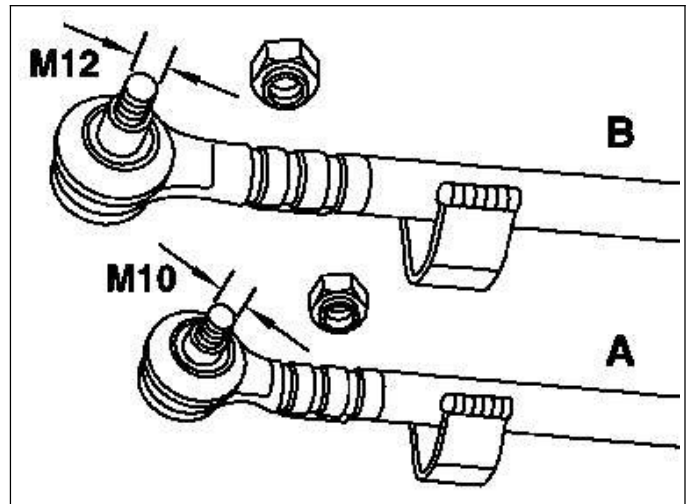

P46-2190-13

On vehicles with 4MATIC, a strengthened drag link which has been turned through 180° has been installed since 03/90.

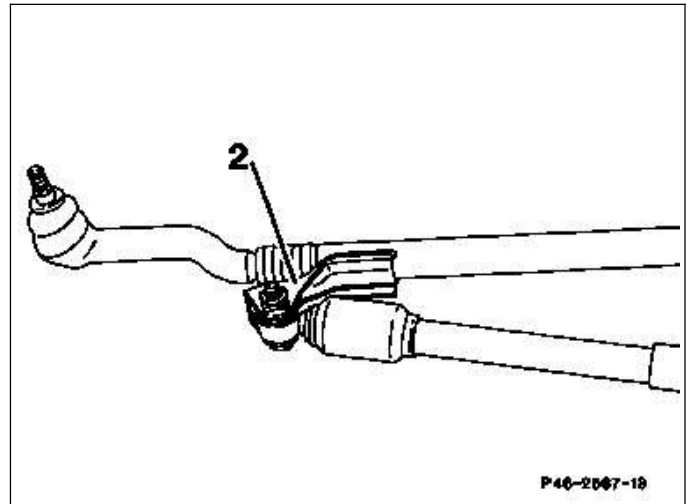

P46-2567-13