

46-0730 Disassembling and assembling power steering pump/tandem pump

Preceding work:
Removing and installing power steering pump/tandem pump
(46-4000).

Operation no. of operation texts and work units or standard texts
and flat rates
46-4079

A. Power steering pump

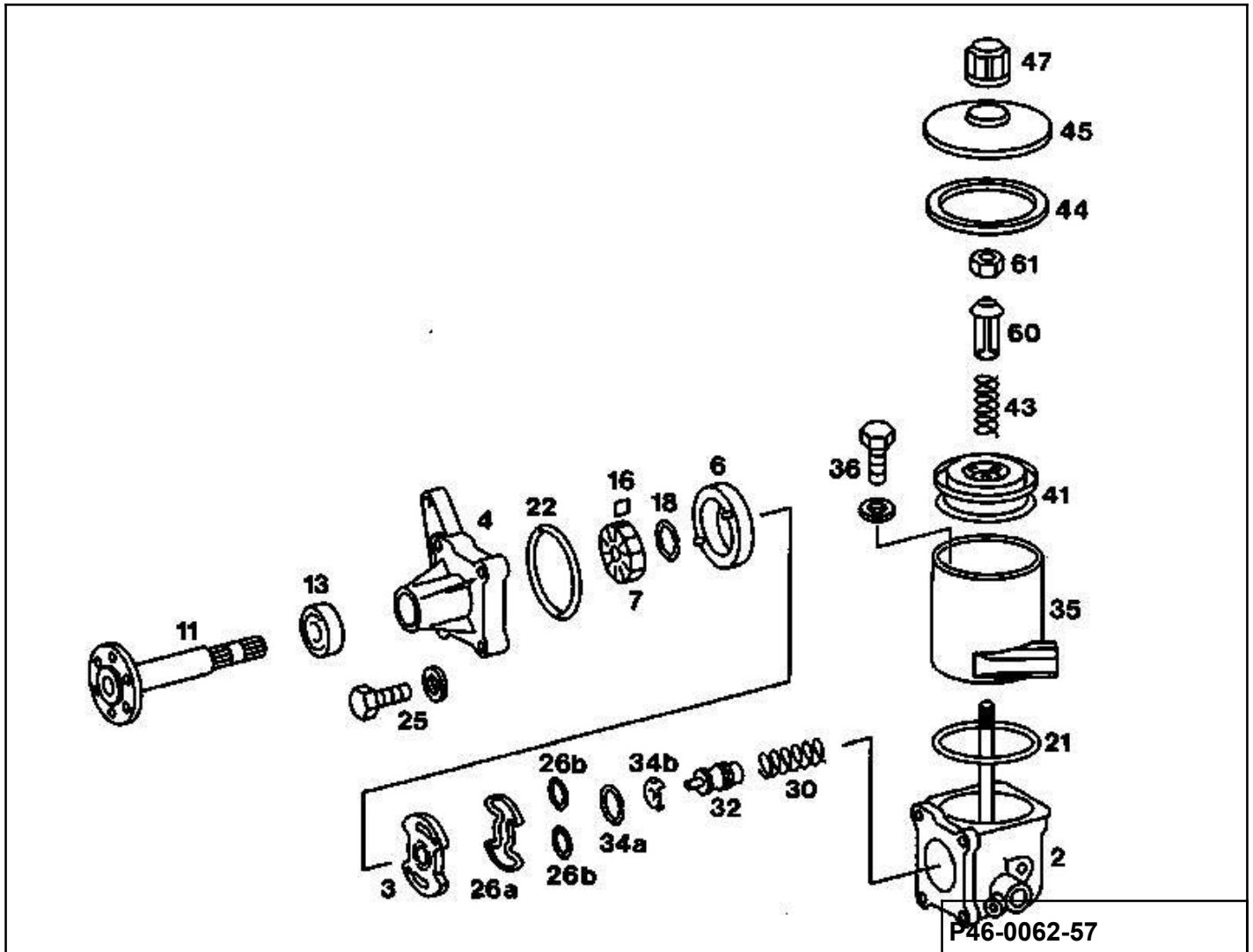

- | | |
|---|--|
| Breather cap (47) and end cover (45)..... | remove, fit on (numbers 1 and 25). |
| Self-locking nut (61)..... | unscrew, screw on, replace (numbers 2 and 25). |
| Plastic sleeve (60), spring (43) and filter set (41)..... | take off, insert (numbers 2 and 25). |
| Vickers/LUK power steering pumps..... | unscrew, screw on fluid reservoir (35). 8 Nm. Replace O-ring (21) (numbers 3 and 24). |
| Bolts (25)..... | unscrew, screw in, take off bearing flange (4). Tightening torque 30-35 Nm (4 and 23). |

Pressure plate (3) and cam insert (6).....	take off (number 5). When assembling, insert cam insert with direction of rotation arrow facing up and pressure plate with ground side facing cam insert (6), into the straight pins (numbers 20 and 22).
Locking ring (18).....	remove, install and replace (numbers 6 and 19).
Rotor (7) with vane (16).....	remove (7) (numbers 7, 18 and 21).
Drive shaft (11).....	remove, insert (numbers 8 and 18).
Radial seal ring (13).....	remove and install, replace. Use suitable fitting mandrel (numbers 9 and 17).
O-ring (22, 26a, 26b).....	replace.
Locking ring (34a or 34b).....	remove, install. Ensure that the flow control valve (32) and the housing bore are not damaged (numbers 10 and 16).
Flow control valve (32) and compression spring (30).....	remove, install (numbers 11, 14 and 15).
Components.....	check for signs of wear (numbers 12-13).

Note

When repairing the power steering pump, always use the repair kit of the respective manufacturer. Scrupulous cleanliness is essential when performing any work on the power steering pump.

The work should be performed, wherever possible, on a plastic base. Chamois cloths are particularly suitable for this kind of work. A strict standard should be applied when examining steering parts. Always replace the part in question in cases of doubt.

3 On the Vickers/LUK power steering pump, the fluid reservoir (35) can be removed. Replace O-ring.

On the ZF power steering pump, the fluid reservoir is cast on to the pump housing (2).

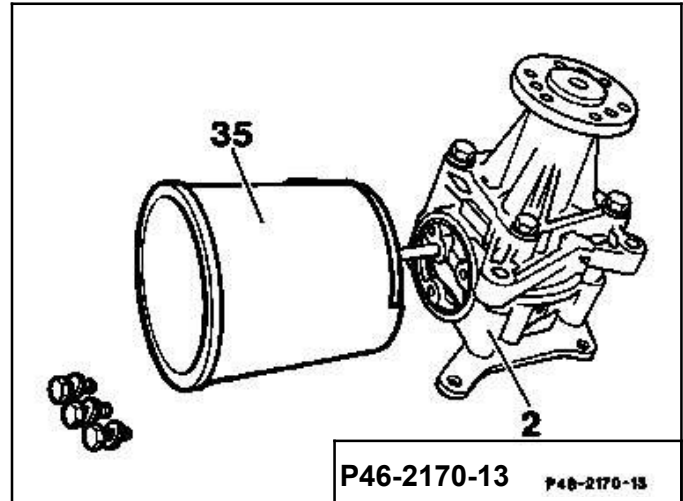

4 Unscrew bolts (25) and take off the bearing flange (4). Examine ground face of bearing flange (4) for signs of damage.

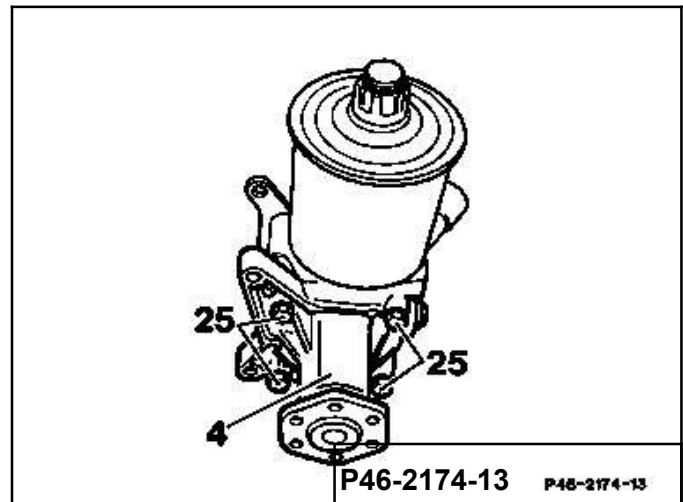

5 Take off pressure plate (3) and cam insert (6).

Examine ground face of pressure plate as well as sliding face of vanes on cam insert (6) for signs of scoring and wear.

There must not be any perceptible scoring present on the sliding face of the cam insert.

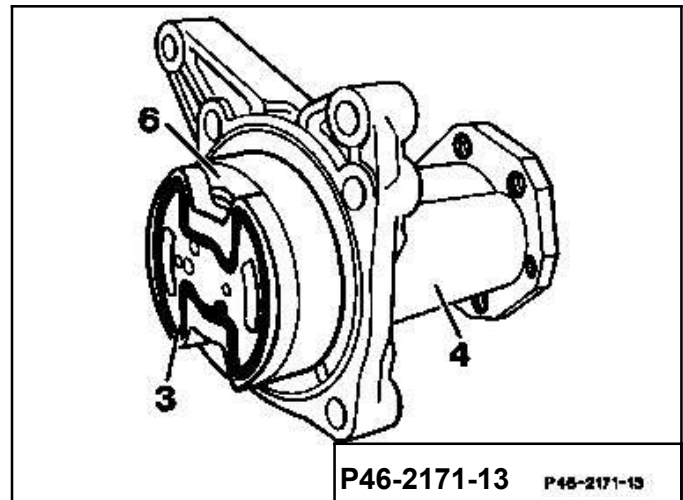

- 6 Take locking ring (18) off the drive shaft (11).
Replace locking ring.

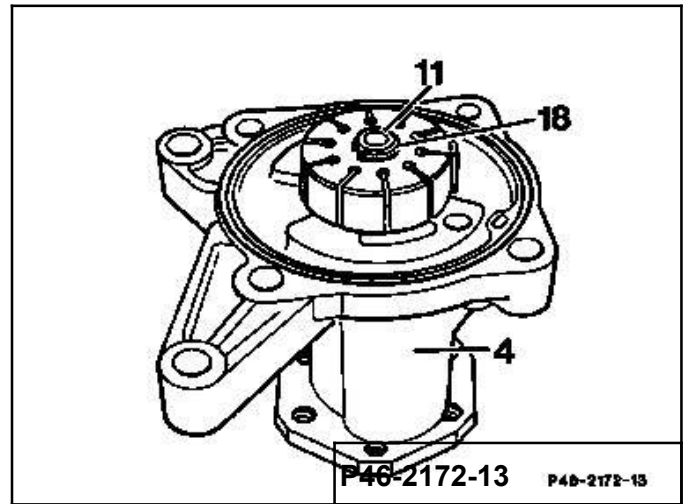

- 7 Detach rotor (7) with a plastic-headed hammer from the drive shaft (11) and take off together with the vanes (10 vanes). Examine the vanes (16) in the grooves of the rotor (7); they must slide easily in the rotor.

Examine sliding face of vanes at cam insert (6) for signs of wear. If necessary, repair power steering pump by using the "Pump operation" repair kit.

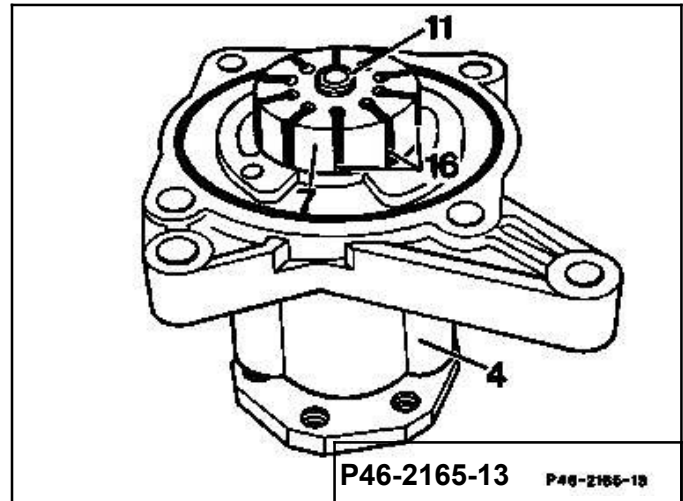

- 8 Remove drive shaft (11) from the bearing flange (4).

Examine drive shaft (11) and bearing bushes for signs of wear.

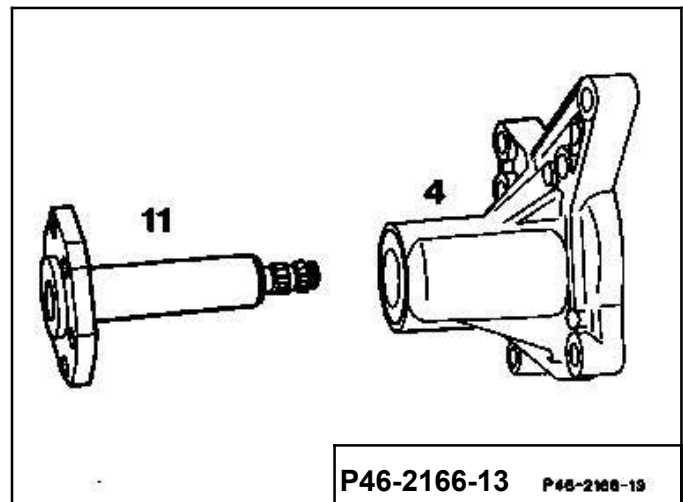

- 9 Use a screwdriver to press radial seal ring (13) out of the bearing flange (4).

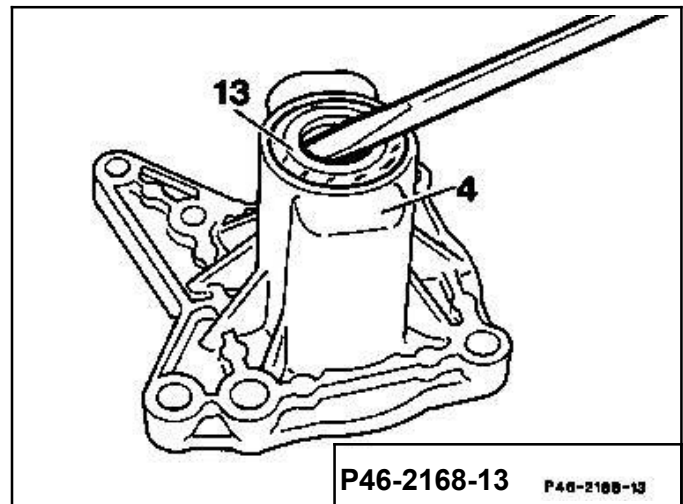

- 10 Remove locking ring (34a or 34b).



When removing locking ring, ensure that the housing bore is not damaged.

34a Vickers/LUK pump
34b ZF pump

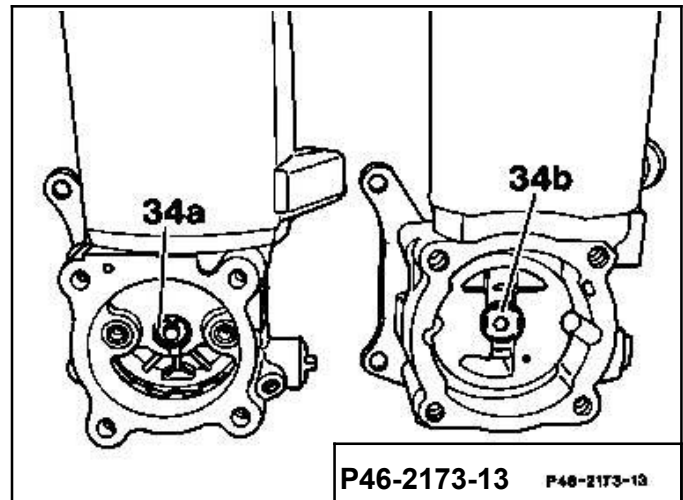

- 11 Remove flow control valve (32) and compression spring (30) from the pump housing (2).

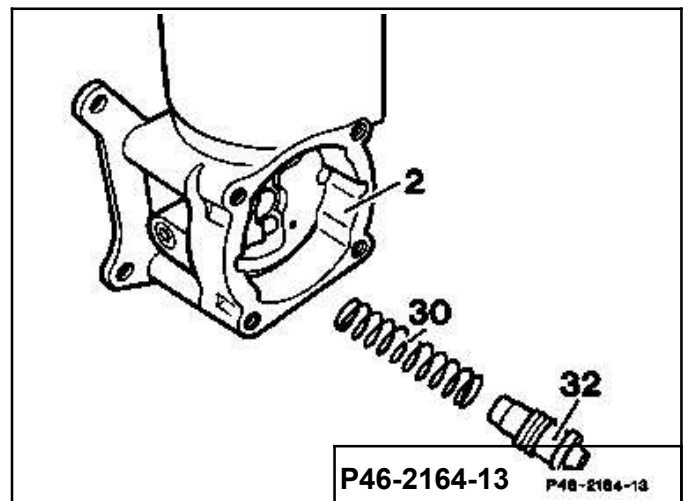

12 Clamp flow control valve (32) in a vise at the part which is not ground, and unscrew valve screw (53) of the overpressure valve.

Remove sealing cone (51) and compression spring (50).

Examine the ground faces of the flow control valve (32) and the bore in the pump housing for signs of wear and damage. If scoring is detected on the sliding faces, **the power steering pump must be replaced.**

13 Check both sealing cones (high-pressure expansion hose, return pipe connection). Replace misshapen sealing cones. This is done by cutting a thread with M7 or M10 a few thread turns deep into the sealing cone. Withdraw the sealing cone from the housing with an M7 or M10 bolt.

Fit new sealing cone into the housing and press into the housing by screwing in the high-pressure expansion hose or the return pipe.

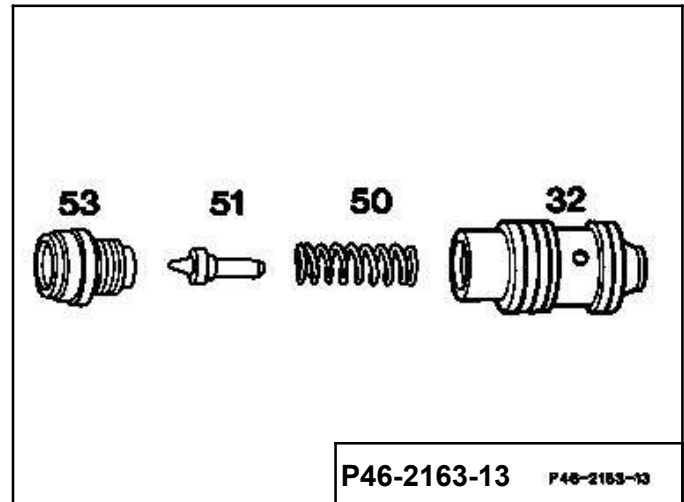

Assembly

Note

Before assembling, moisten all parts with oil.

Replace all O-rings.

If fitting a new flow control valve, pay attention to the correct opening pressure of the overpressure valve.

- 14 Assemble flow control valve (32), by clamping flow control valve (32) in a vise at the part which is not ground, and tightening valve screw.

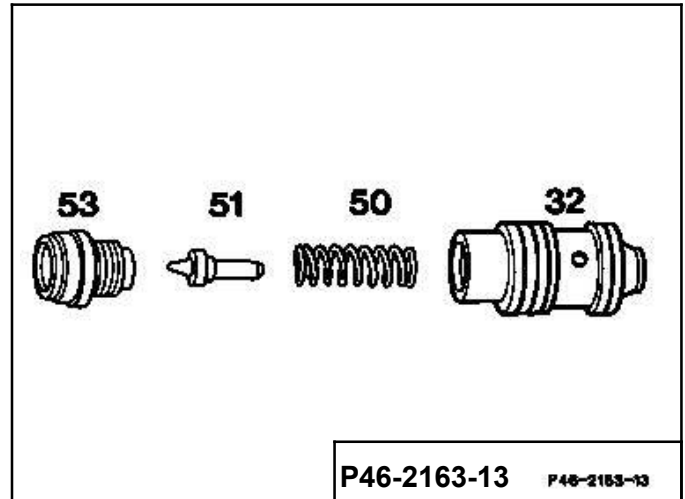

- 15 Insert compression spring (30) and flow control valve (32) into the pump housing (2).

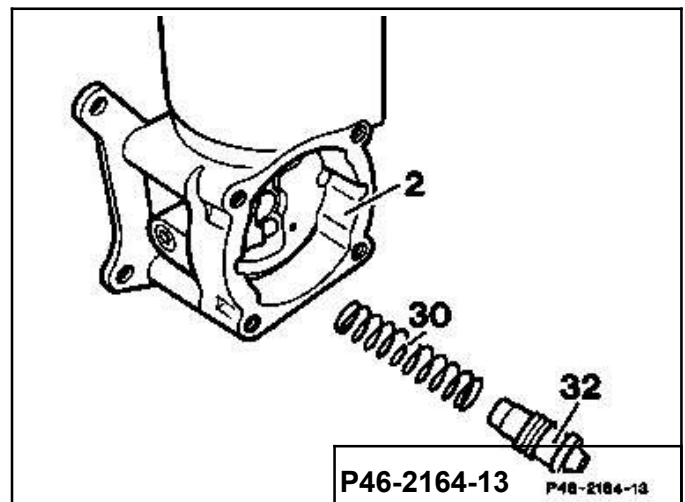

- 16 Install locking rings (34a and 34b). Ensure that the flow control valve and the bore in the pump housing are not damaged.

34a Vickers/LUK pump
 34b ZF pump

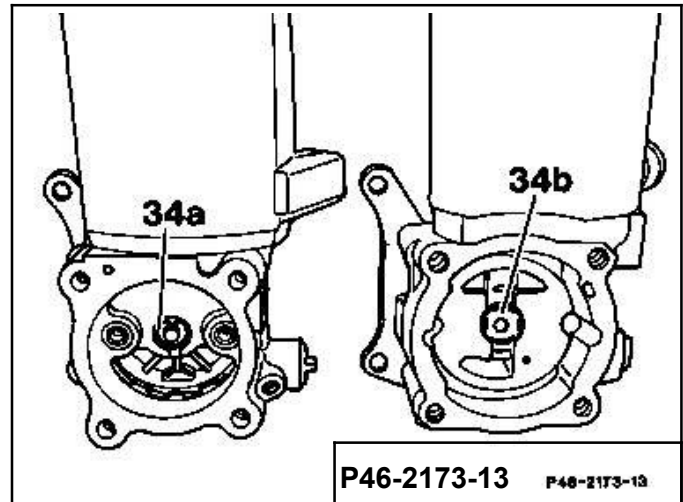

- 17 Press new radial seal ring into bearing flange with a suitable mandrel.

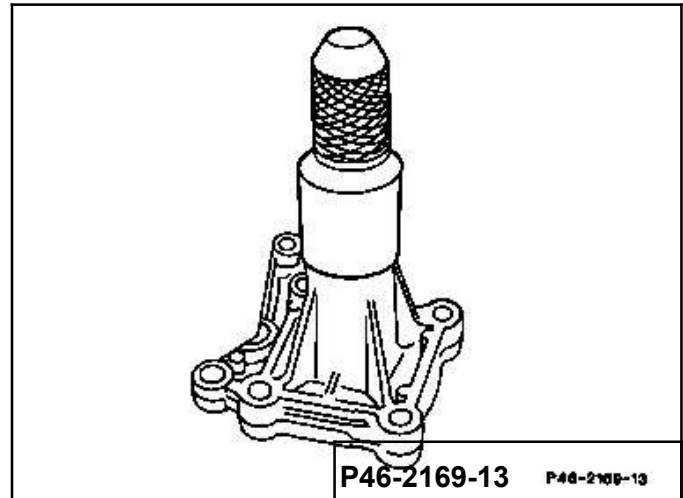

- 18 Insert drive shaft (11) into the bearing flange (4). After this, fit rotor (7) with the chamfer on the inner diameter facing the flange of the drive shaft.

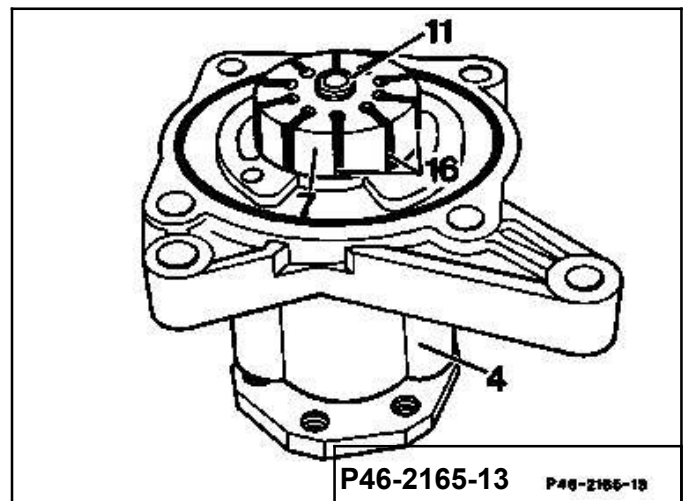

- 19 Fit new locking ring (18) onto the drive shaft. Ensure that the locking ring is correctly seated in the groove.

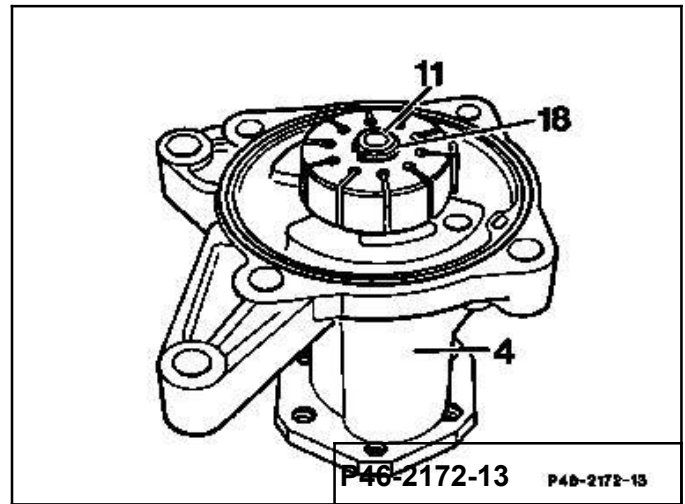

- 20 Insert the cam insert with the cast or stamped-in direction of rotation arrow (arrows) facing upwards into straight pins on the pump housing.

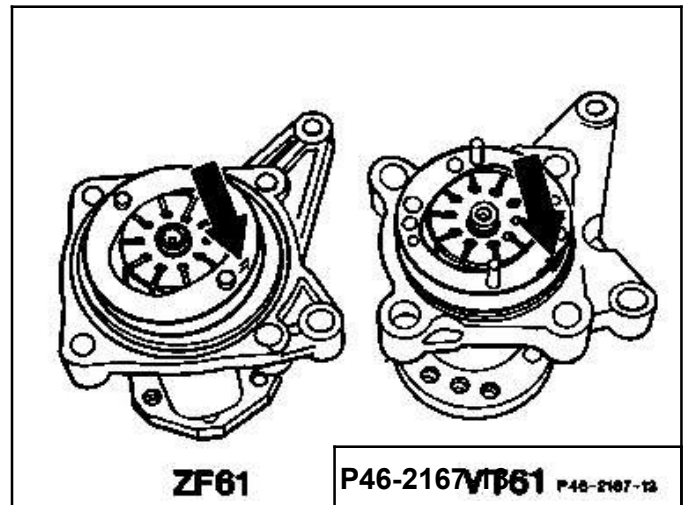

- 21 Insert vanes (10 off) into the rotor with the rounded, metallic glossy sides (arrow) facing the cam insert.

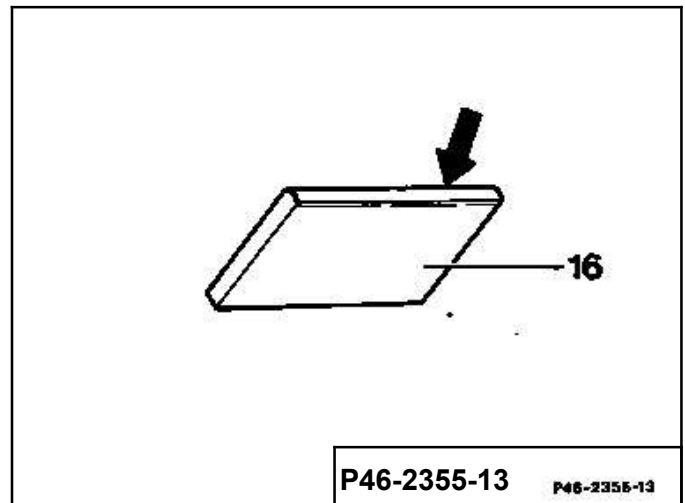

- 22 Fit on pressure plate (3) with ground face pointing toward cam insert (6).

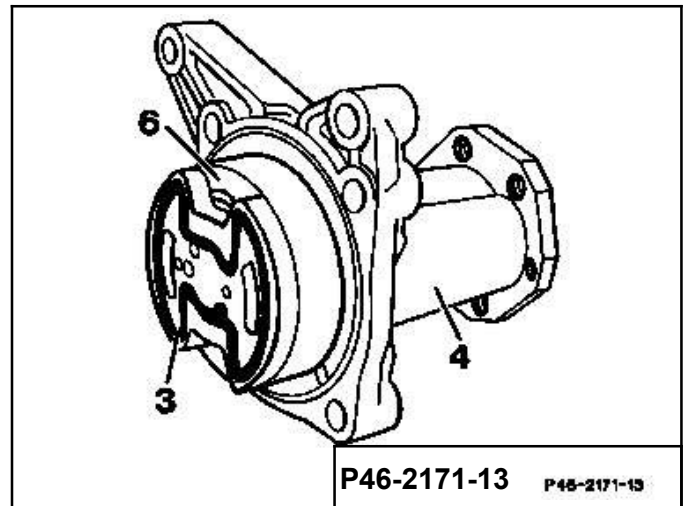

- 23 Insert O-rings in bearing flange, then insert bearing flange (4) in the pump housing and attach with the hexagon bolts (25).
Tightening torque 30-35 Nm.

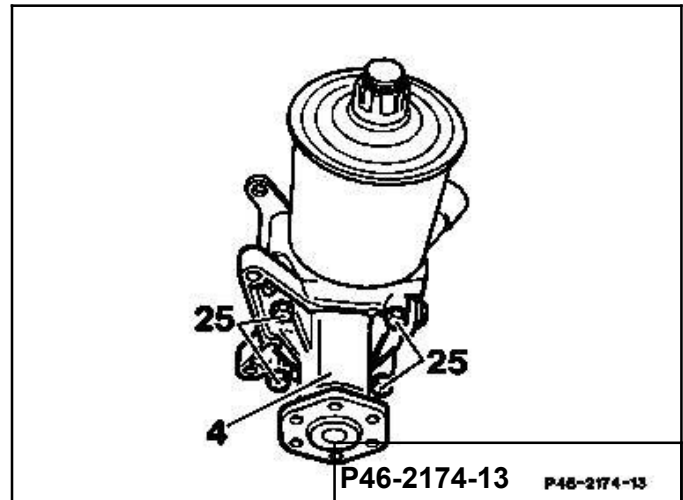

- 24 On the Vickers/LUK power steering pump, insert new O-ring, then fit on reservoir (35) and attach with the bolts.
Tightening torque 8 Nm.

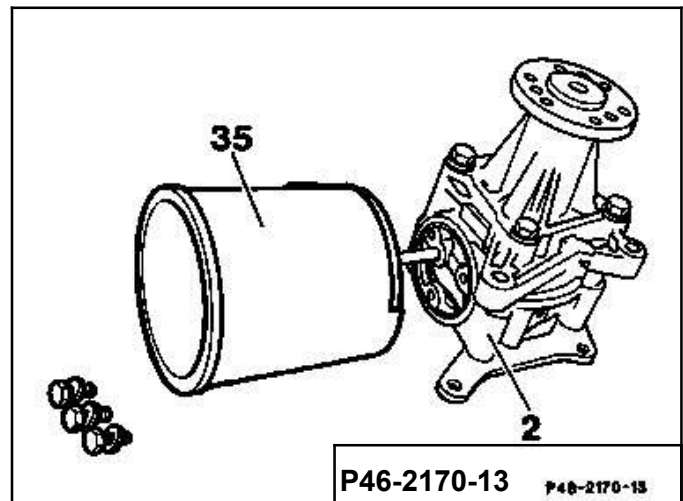

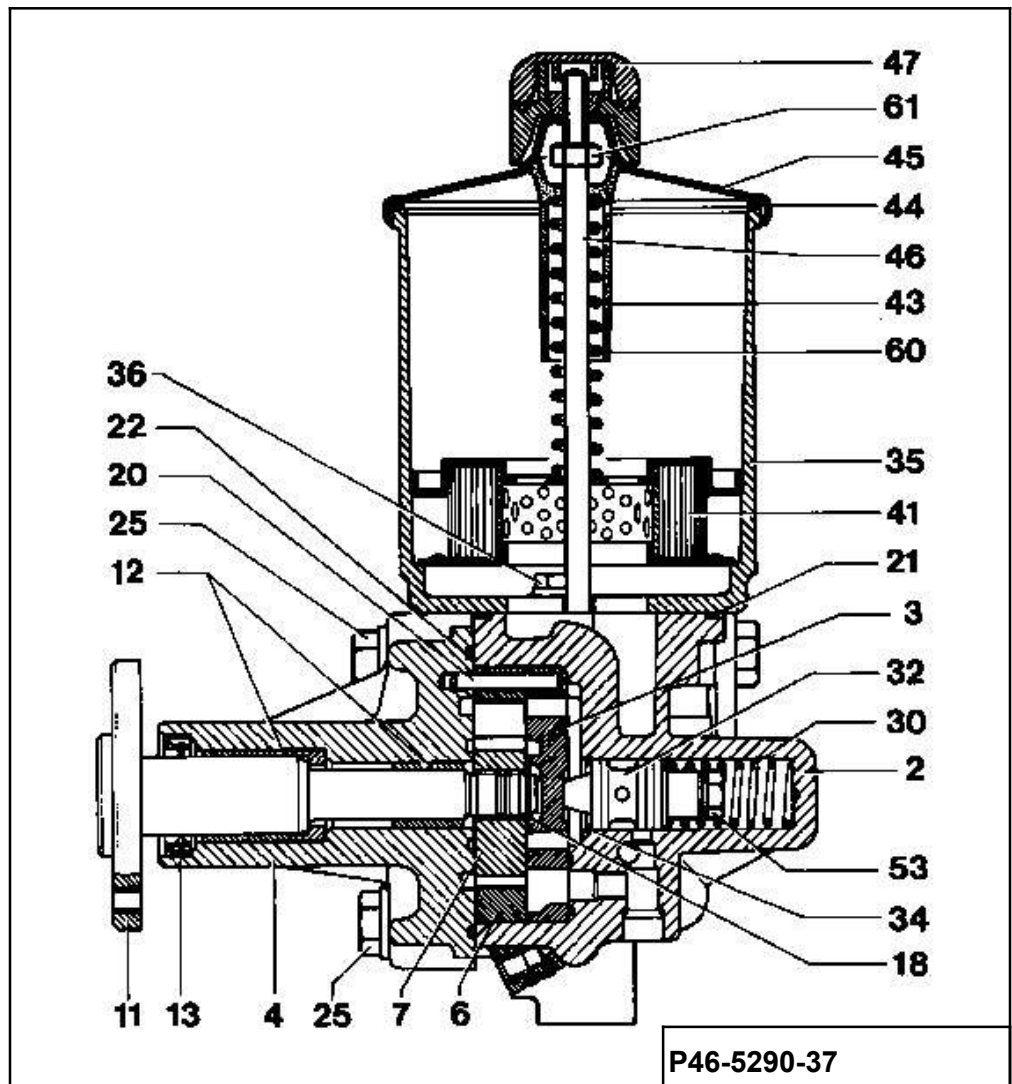

- 25 Insert filter set (41), spring (43) and plastic sleeve (60), compress slightly and install new self-locking nut (61). Fit on end cover (45), screw on breather cap (47).
- 26 After installing power steering pump (operation no. 46-4000), check that power steering pump operates properly and is free of leaks. If necessary, connect pressure gauge and test delivery pressure (46-3070). Fill or bleed systems (46-0715).

B. Tandem pump - models 62, 162

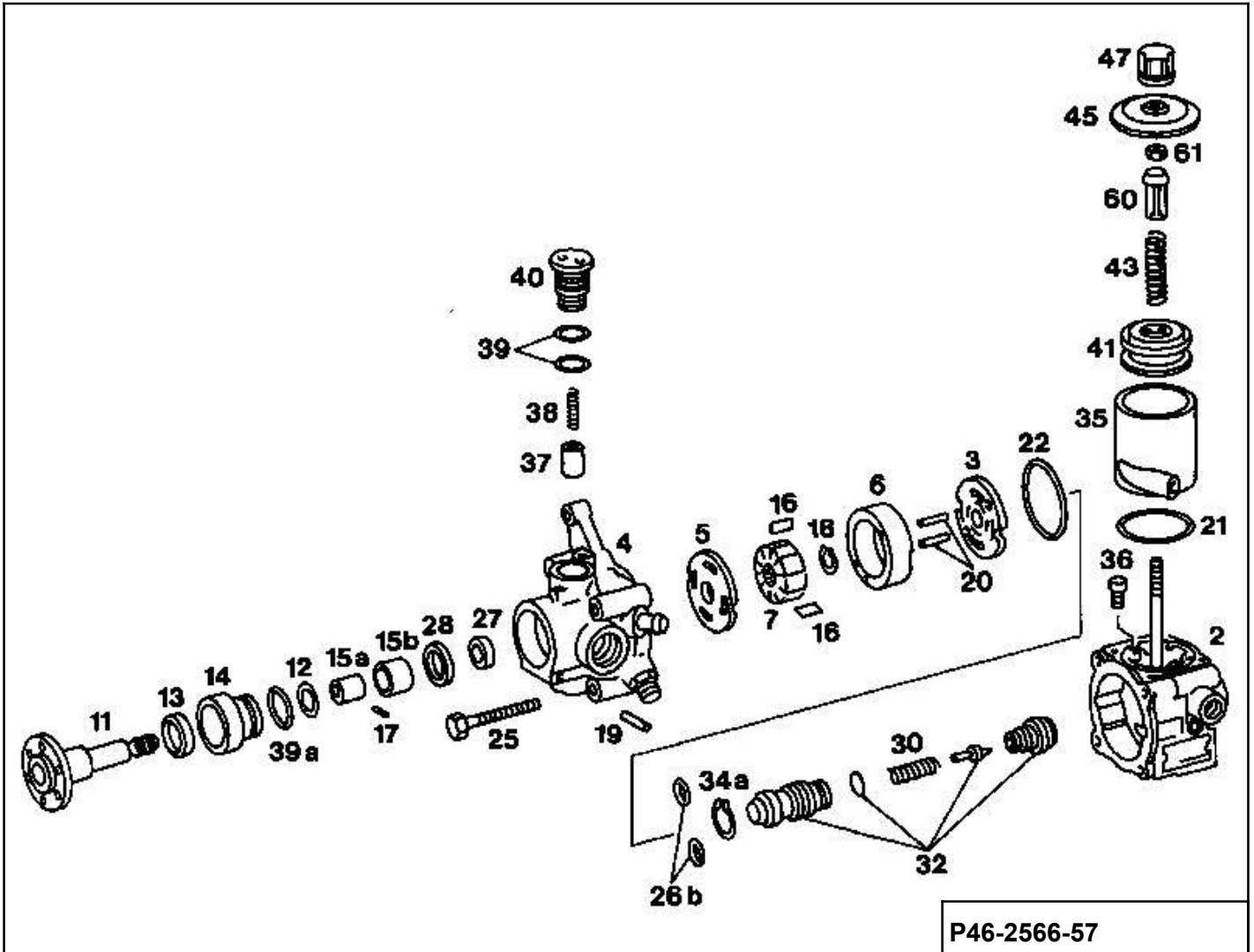

- | | |
|---|--|
| Breather cap (47)..... | remove, install end cover (45) (numbers 1 and 43). |
| Self-locking nut (61)..... | unscrew, screw on, replace (numbers 2 and 43). |
| Plastic sleeve (60), spring (43) and filter set (41)..... | take off, install (numbers 2 and 43). |
| Fluid reservoir (35)..... | unscrew, screw on, 8 Nm, replace O-ring (21) (numbers 3 and 42). |
| Bolts (25)..... | unscrew, screw in, 30-35 Nm, take off bearing flange (4), check O-rings (22 and 26b) (numbers 4 and 41). |
| Pressure plate (3) and cam insert (6)..... | take off. When installing, insert cam insert with direction of rotation arrow facing up, and pressure plate (3) with the ground side facing cam insert (6), into straight pins (20) (numbers 5, 6 and 39). |
| Locking ring (18)..... | remove, install and replace (numbers 7 and 37). |
| Rotor (7)..... | take off, fit on rotor with chamfer on inner diameter facing flange of drive shaft (numbers 8 and 36). |
| Thrust washer (5)..... | remove, install (numbers 9 and 35). |

4 screw cartridges (40).....	unscrew, screw in with pronged wrench 129 589 02 07 00, 40±5 Nm, check O-rings (39), replace if necessary (numbers 10, 11, 33 and 34).
Piston (37).....	check for ease of movement (number 11).
Roll pin (19).....	knock out, knock in with suitable mandrel (numbers 12 and 32).
Drive shaft (11) with sleeve (15b) and bearing flange (14).....	take out of housing (4), insert. Pay attention to installed position (numbers 13 and 32).
Sleeve (15b).....	remove, install, check (numbers 14 and 31).
Eccentric (15a).....	take off after knocking out roll pin (17), fit on (numbers 15 and 30).
Thrust washer (12).....	take off, fit on (numbers 16 and 30).
Bearing flange (14).....	pull off drive shaft, fit on (numbers 17 and 29) Replace O-ring (39a). Check drive shaft at bearing points for signs of wear (number 19).
Radial seal ring (13).....	remove, install, replace. Use suitable mandrel (numbers 18 and 29).
Radial seal ring (27).....	check, if necessary remove from housing (4) with puller 000 589 33 33 00 and 116 589 05 34 00 together with washer (28), replace. Press in new radial seal ring (27) as far as the stop. Press in washer (28) with groove facing radial seal ring (27) (numbers 20, 21, 27 and 28).
Flow control valve (32).....	remove, install, disassemble and check (numbers 23 and 24).

Note

When repairing the tandem pump, always use the repair kit of the respective manufacturer.

Scrupulous cleanliness should be observed when performing any work on the tandem pump. The work should be performed on a plastic base, if possible; chamois leathers are particularly suitable for this kind of work.

A strict standard should be applied when examining steering parts.

Special tools

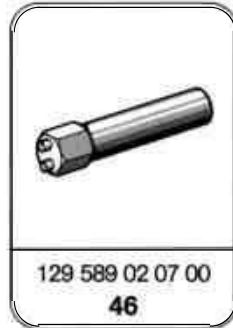
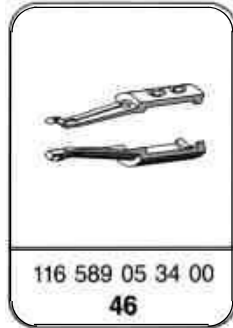
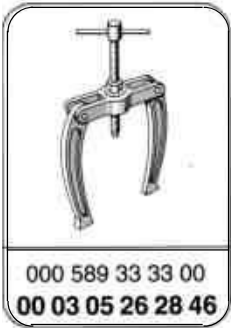

Disassembly

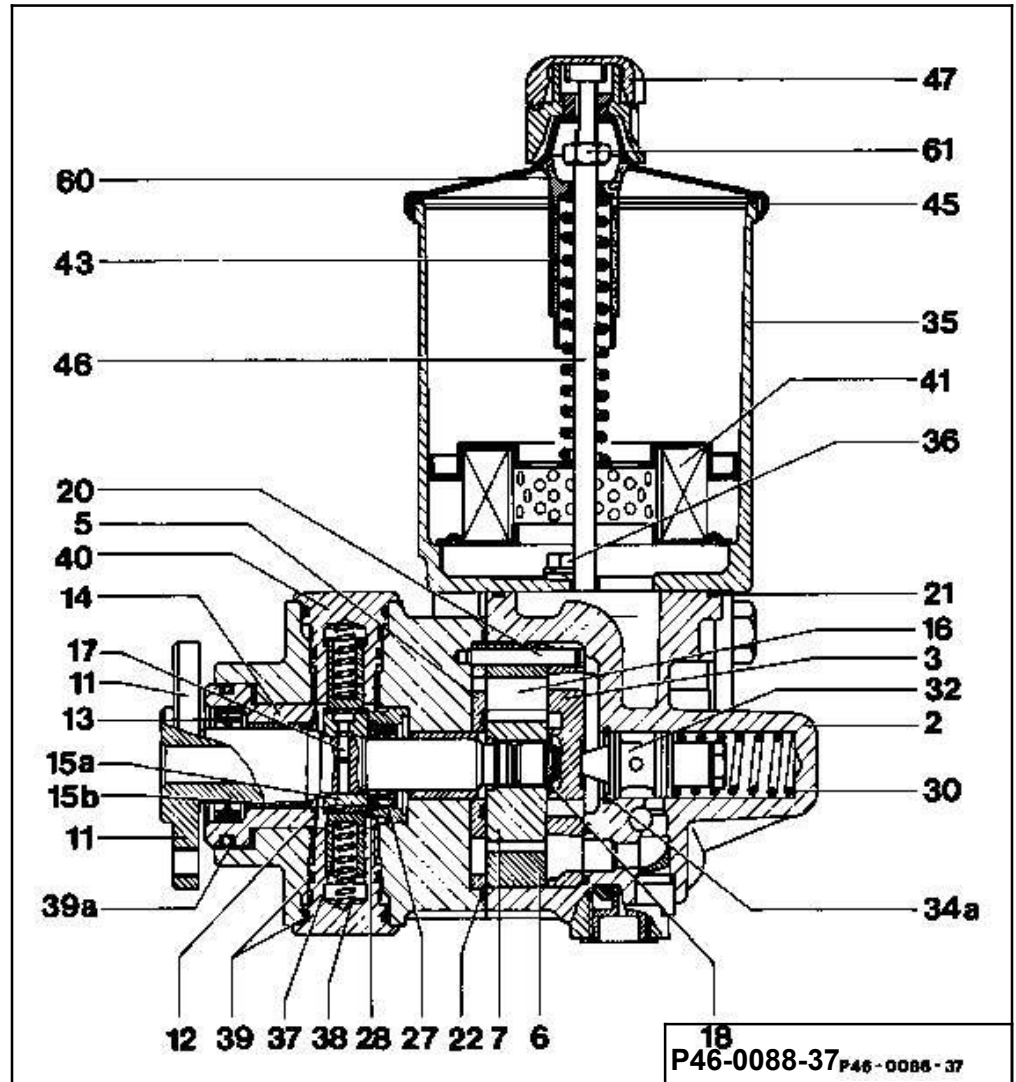

1 Screw down breather cap (47), take off end cover (45).

2 Screw down self-locking nut (61) of the stud bolt (46). Take off plastic sleeve (60), spring (43) and filter set (41).

- 3 Unscrew bolts (36) from the pump housing (2).
Take off fluid reservoir (35) and replace O-ring (21).

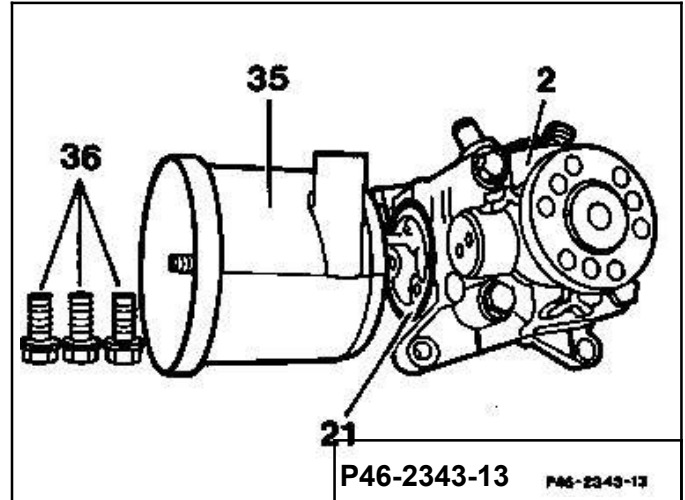

- 4 Unscrew bolts (25) and take off the bearing flange.
Examine ground face of bearing flange for signs of damage.

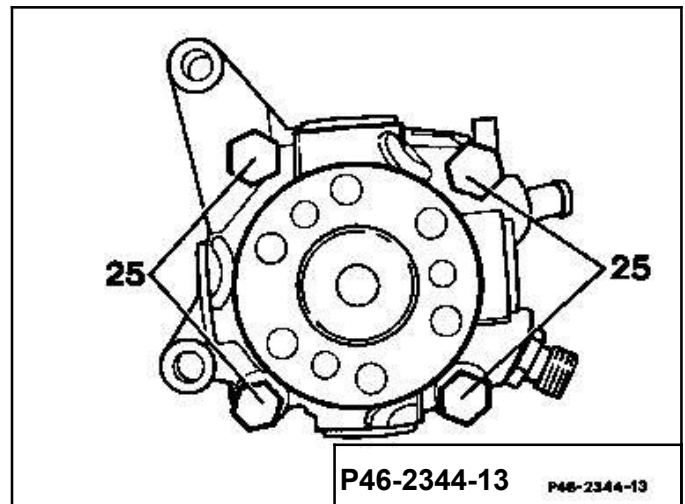

- 5 Take off pressure plate (3).

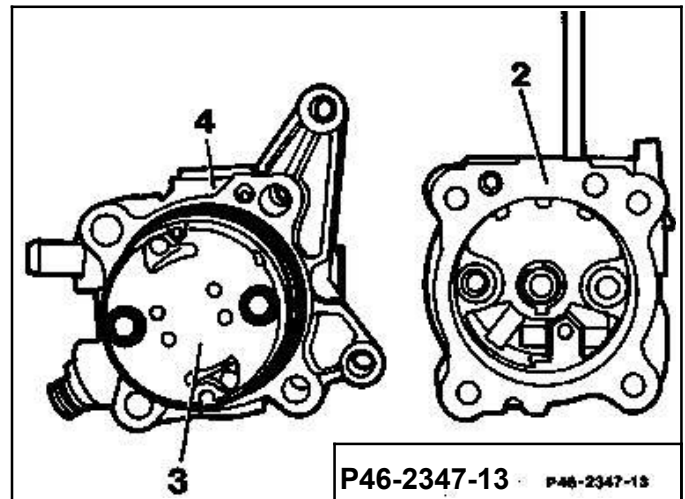

6 Take off cam insert (6).

Examine ground face of pressure plate as well as sliding face of vanes on cam insert (6) for signs of scoring and wear.

There must not be any perceptible scoring present on the sliding surface of the cam insert.

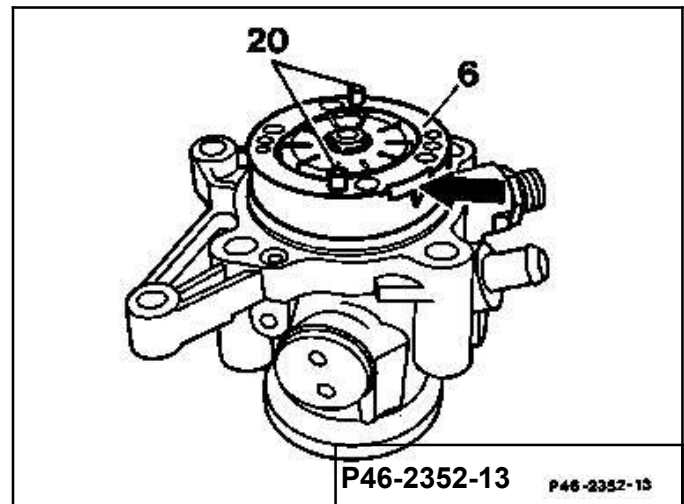

7 Take locking ring (18) off the drive shaft.
Replace locking ring.

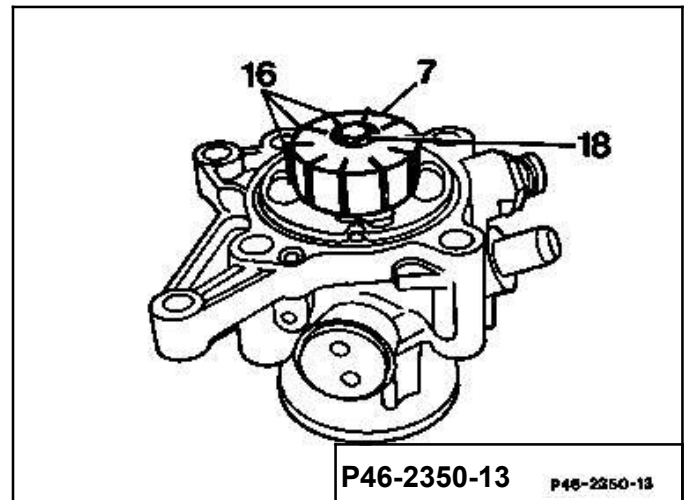

8 Detach rotor (7) from the drive shaft (11) with a plastic-headed hammer and take off together with the vanes (10 off). Check the vanes (16) in the grooves of the rotor (7); they must slide easily in the rotor.

Check sliding face of vanes at cam insert for signs of wear. If necessary, repair power steering pump by using the "Pump insert" repair kit.

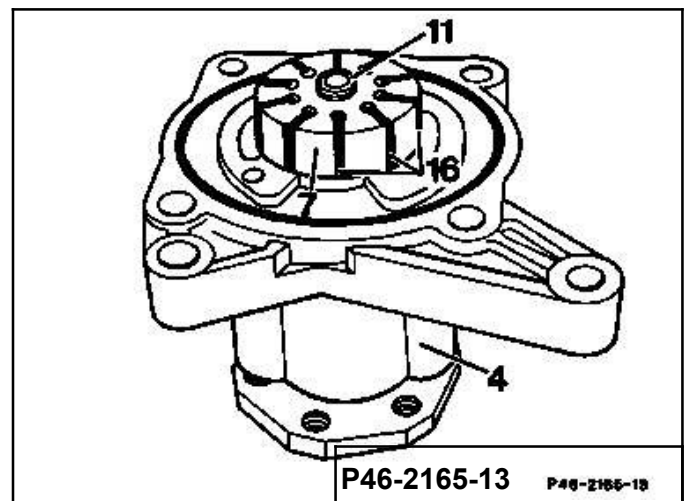

9 Take off thrust washer (5).

Note

On tandem pumps (1st version), no thrust washer (5) is fitted. If, on these tandem pumps, it is found that the drive shaft does not move freely, is seized or fractured, the tandem pump must be replaced.

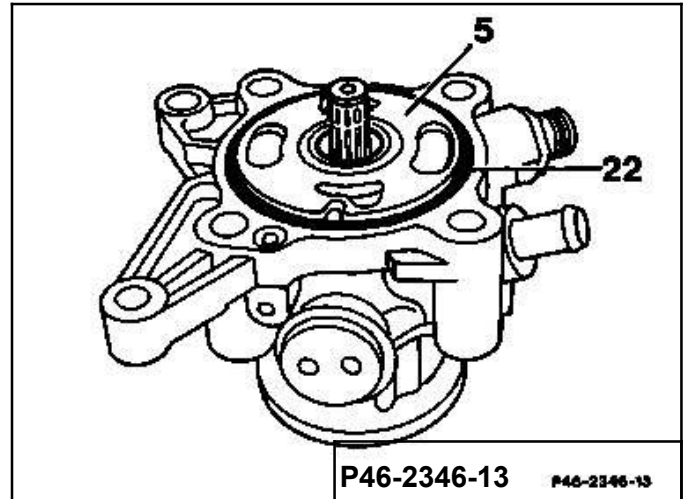

10 Number screw cartridges (40) consecutively from 1-4, then unscrew all 4 screw cartridges (40) from the housing with the pin wrench (010) part no. 129 589 02 07 00.

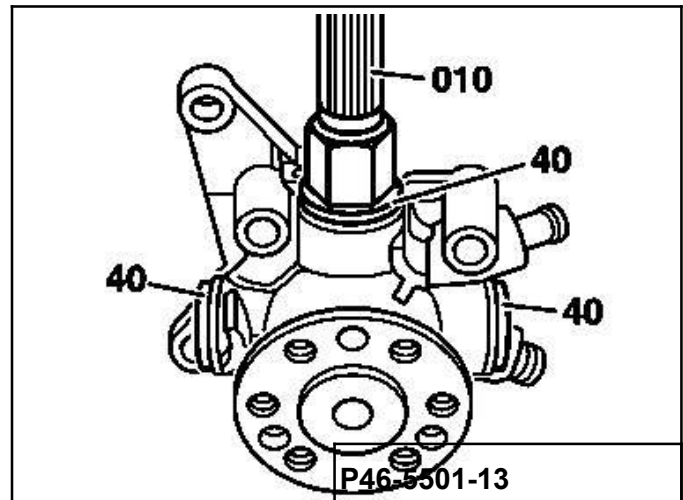

11 Check seals (39), replace if necessary. Take piston (37) and spring (38) out of the screw cartridge (40). Examine piston and piston track for signs of damage and wear. It must be possible to move the piston in the screw cartridge (40) easily and without it jamming. If this is not the case, replace the screw cartridge.

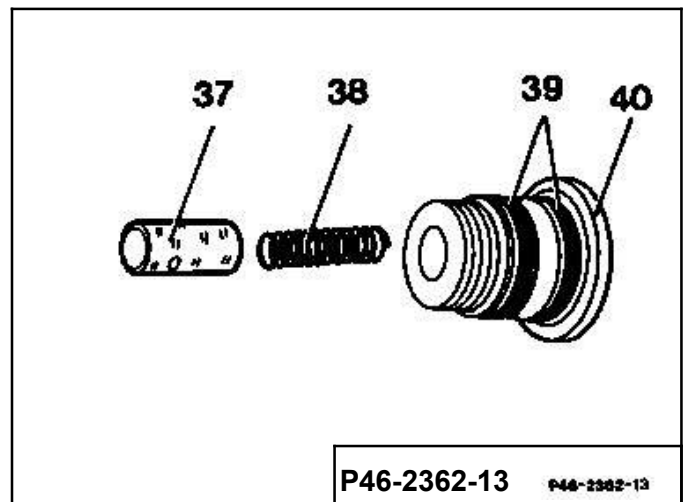

12 Knock roll pin (19) out of the housing with a suitable mandrel.

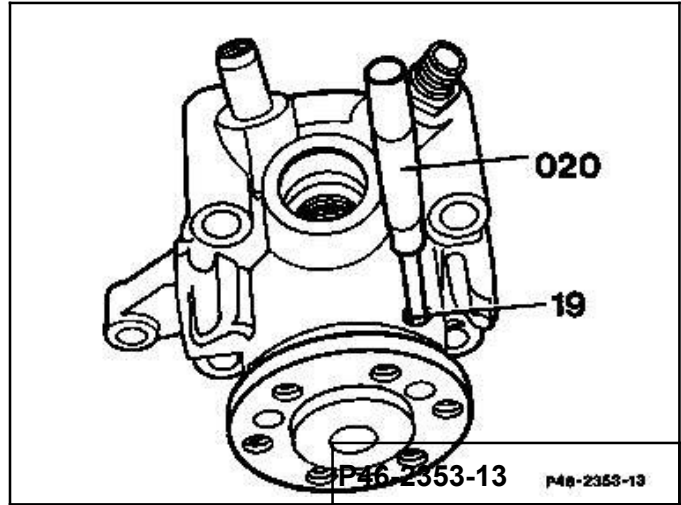

13 Take drive shaft (11) together with sleeve (15b) and bearing flange (14) out of the housing.

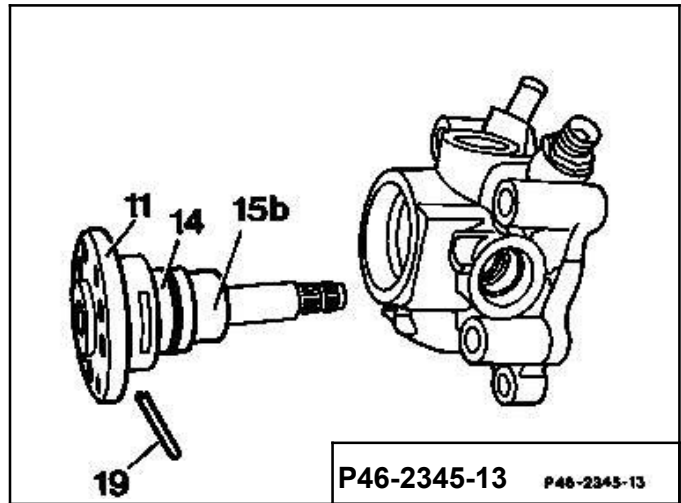

14 Take off sleeve (15b), check.

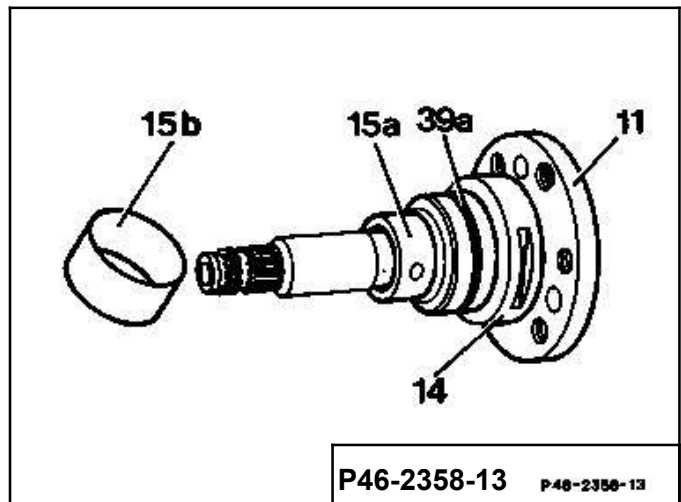

- 15 Knock out pin (17) with mandrel and take off eccentric (15a).
- 16 Take off thrust washer (12), check.
- 17 Pull bearing flange (14) off the drive shaft (11).

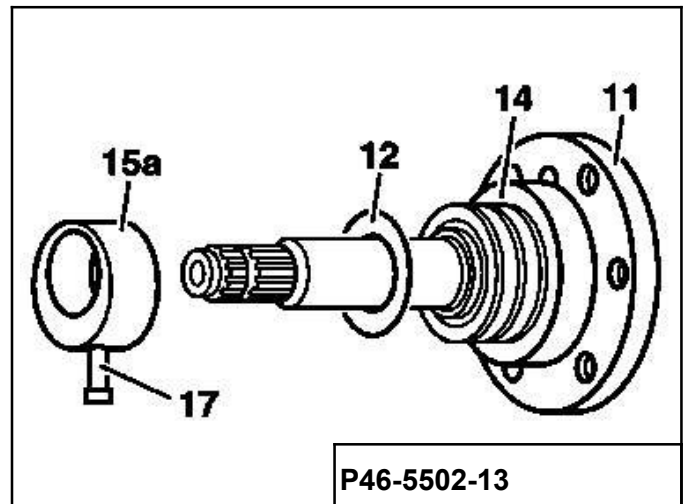

- 18 Use a screwdriver to press radial seal ring (13) out of the bearing flange.
- Examine bronze bush in bearing flange for signs of damage and wear. If scoring and signs of rubbing are detectable, the bearing flange should be replaced completely.
Replace O-ring (39a).

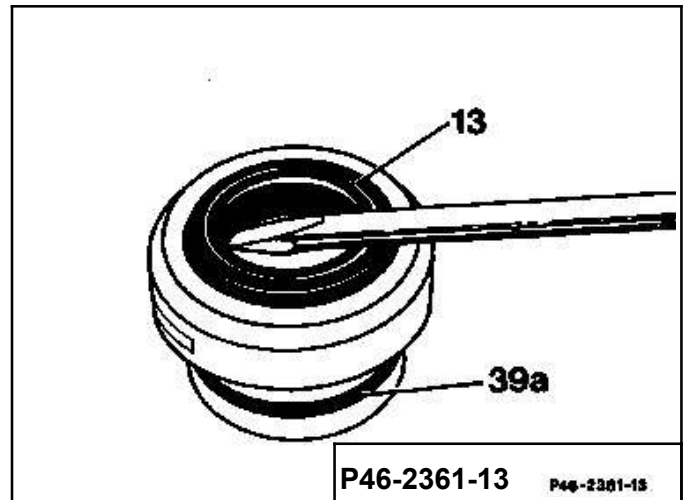

- 19 Examine bearing points (arrows) of drive shaft for signs of scoring and wear.

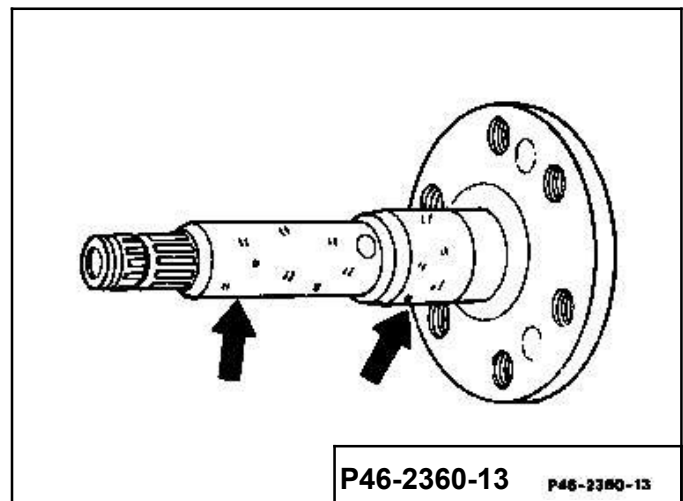

- 20 Check radial seal ring (27) in the housing. If oil from the high-pressure system is found in the servo circuit or vice versa, the cause may be the radial seal ring (27).

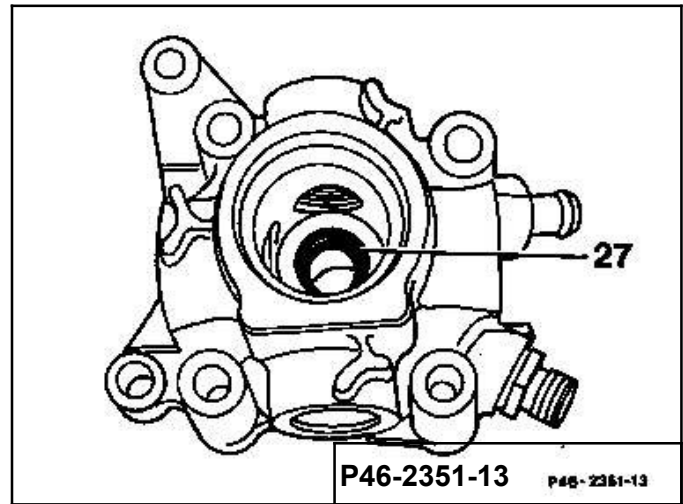

- 21 Pull out radial seal ring and washer (28) with internal extractor 000 589 33 33 00. Examine bronze bush in housing (4) for signs of damage and wear, replace housing, if necessary.

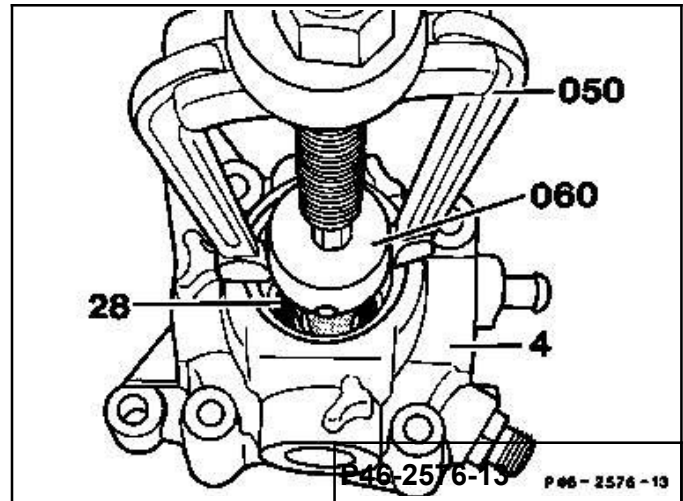

- 22 Remove locking ring (34a).



When removing locking ring, ensure that the housing bore is not damaged.

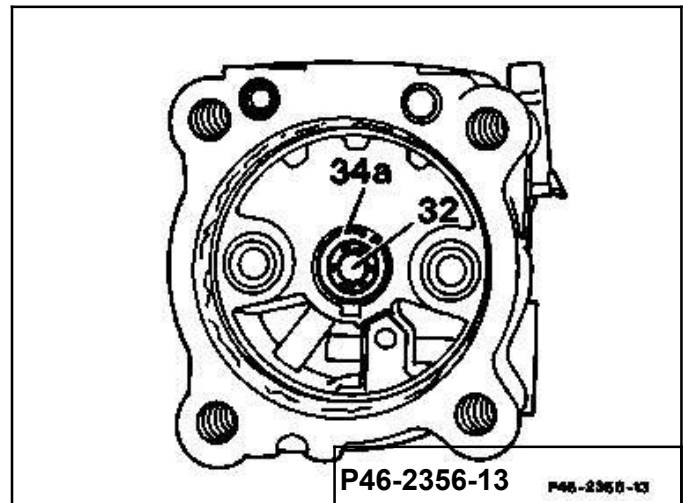

- 23 Take flow control valve (32) and compression spring (30) out of the pump housing (2).

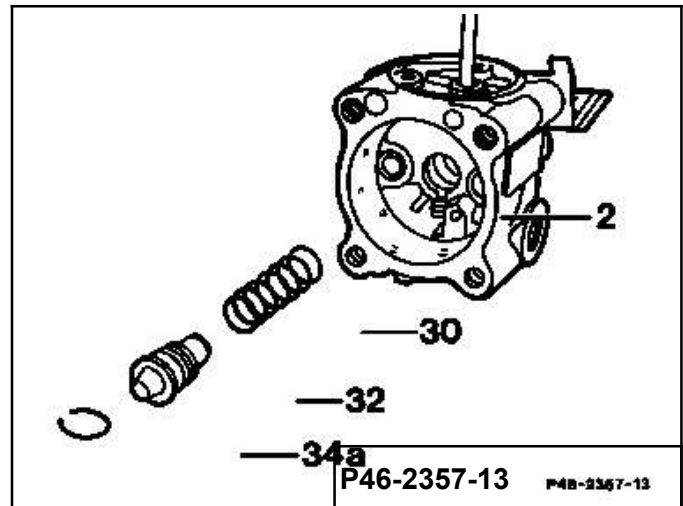

- 24 Clamp flow control valve (32) in a vise at a part which is not ground and unscrew valve screw (53) of the overpressure valve.

Take out sealing cone (51) and compression spring (50).

Examine the ground faces of the flow control valve (32) and the bore in the pump housing for signs of wear and damage. If scoring is found on the sliding surfaces, **the tandem pump must be replaced**.

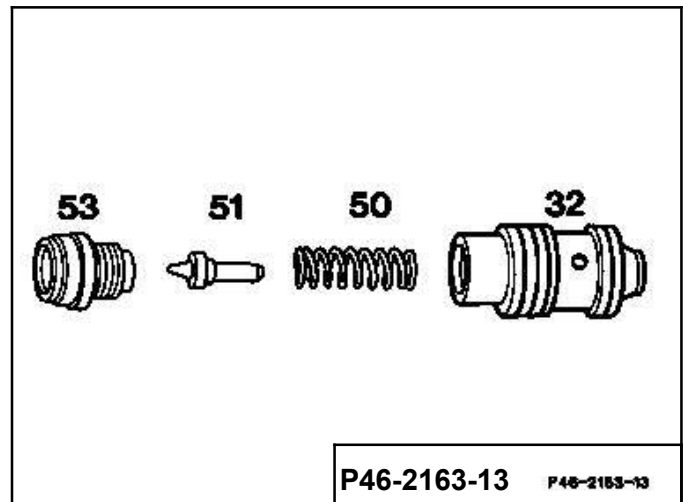

- 25 Check both sealing cones (high-pressure expansion hose, return pipe connection).

Replace misshapen sealing cones. This is done by cutting a thread with M7 or M10 a few thread turns deep into the sealing cone. Withdraw the sealing cone from the housing with an M7 or M10 bolt.

Fit on new sealing cone in housing and press into the housing by screwing in the high-pressure expansion hose or the return pipe.

Assembly

Note

Before assembling, moisten all parts with oil.

Replace all O-rings.

If fitting a new flow control valve, pay attention to the correct opening pressure of the overpressure valve.

- 26 Assemble flow control valve (32), carefully insert together with spring (30) into the pump housing (2) and secure with locking ring (34a).

The valve must slide easily in the bore of the housing.

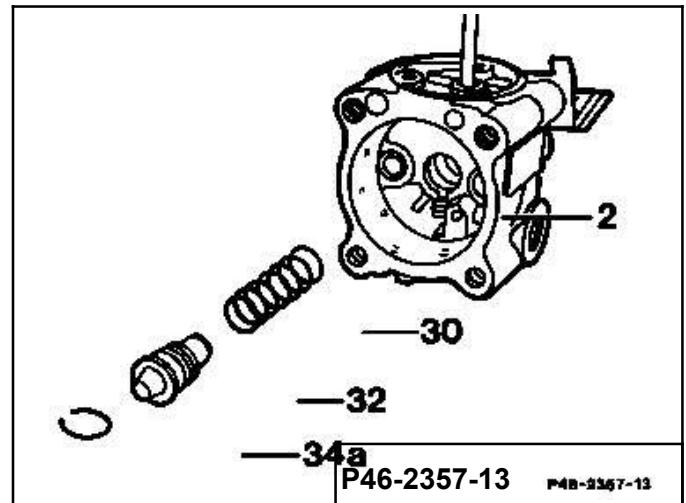

- 27 Press in radial seal ring (28) as far as the stop with a suitable mandrel.

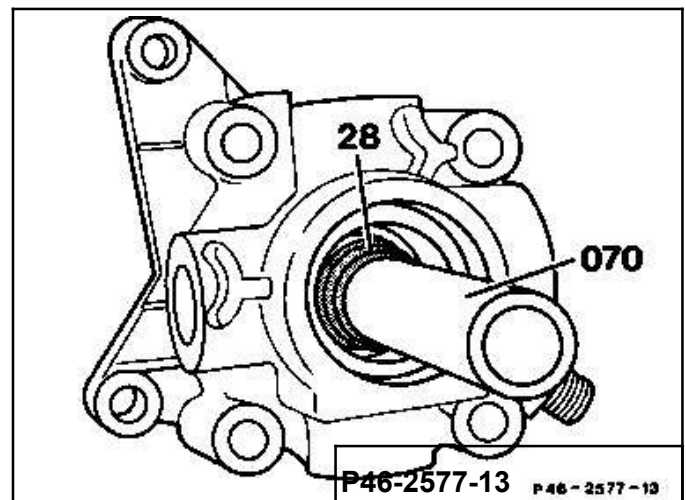

28 Press spacer ring (27) into the housing (4) with groove facing seal.

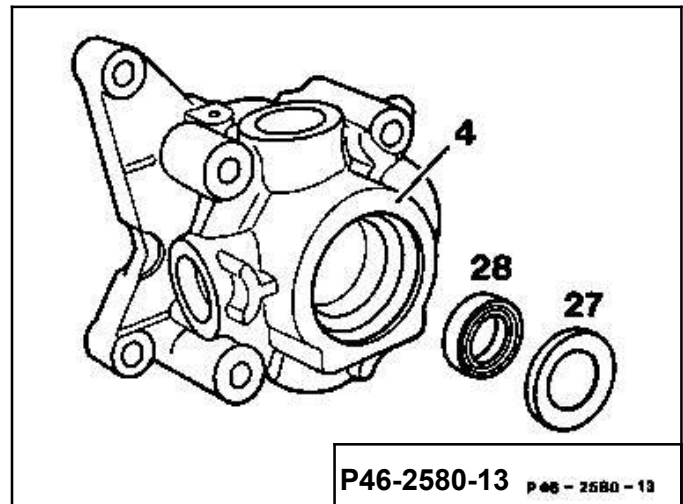

29 Press radial seal ring (13) into the bearing flange (14) using a suitable mandrel (030).
Fit on O-ring.
Carefully insert drive shaft into bearing flange.

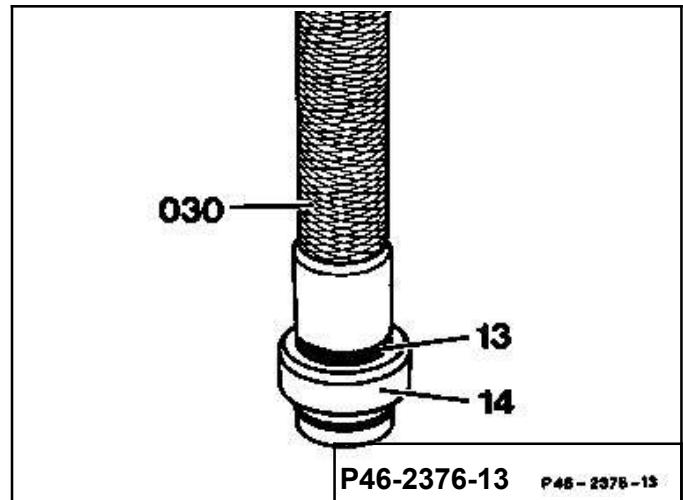

30 Fit thrust washer (12) and eccentric (15a) onto the drive shaft. Secure eccentric with pin (17).
Knock pin as far as the stop.

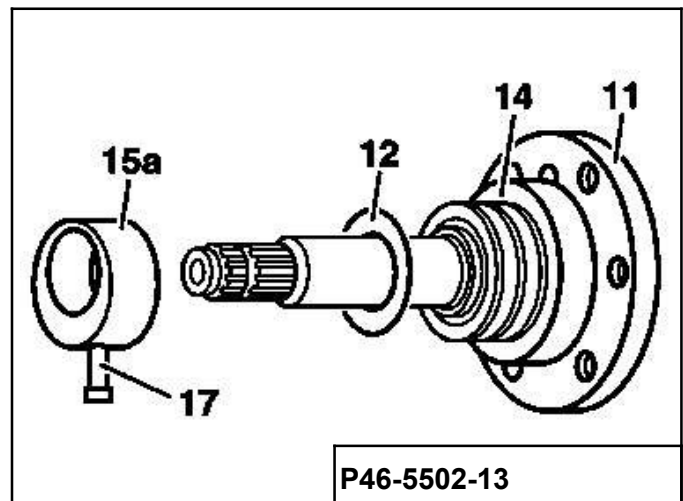

31 Push oiled sleeve (15b) over the eccentric (15a).

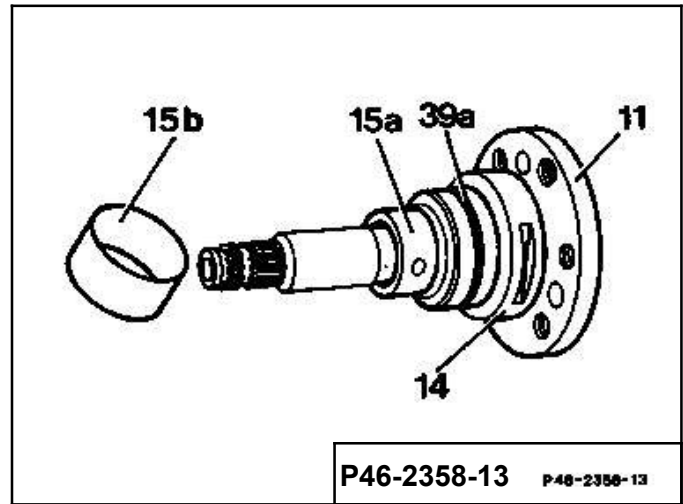

32 Carefully insert drive shaft (11) together with bearing flange (14) into the housing (do not damage seal). Ensure that the groove for the roll pin (19) is parallel to the roll pin bore. Knock roll pin (19) into the housing.

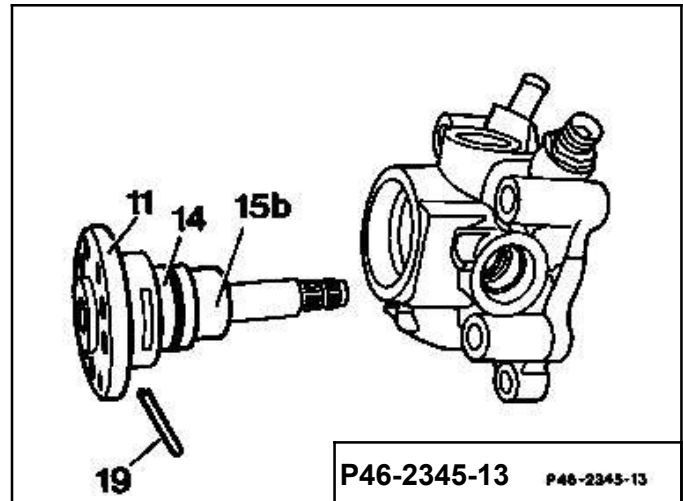

33 Insert spring (38) and piston (37) into the screw cartridge (40). Piston and housing must always be matched to each other.

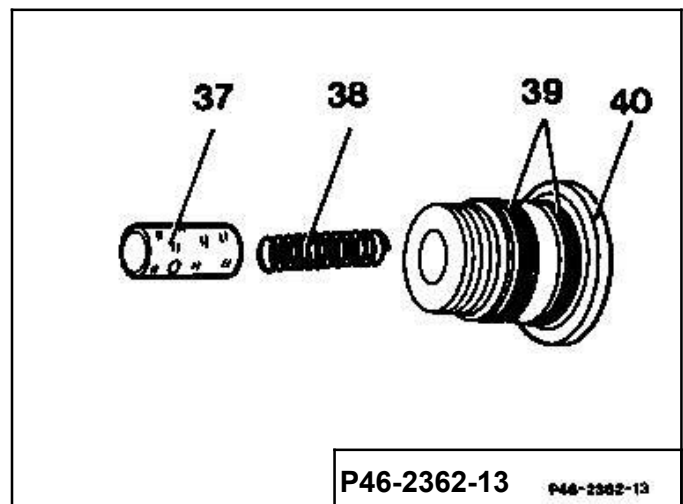

- 34 Screw all 4 screw cartridges (40) into the housing in the consecutively numbered order shown in number 10, 40 ± 5 Nm. Use pronged wrench 129 589 02 07 00.

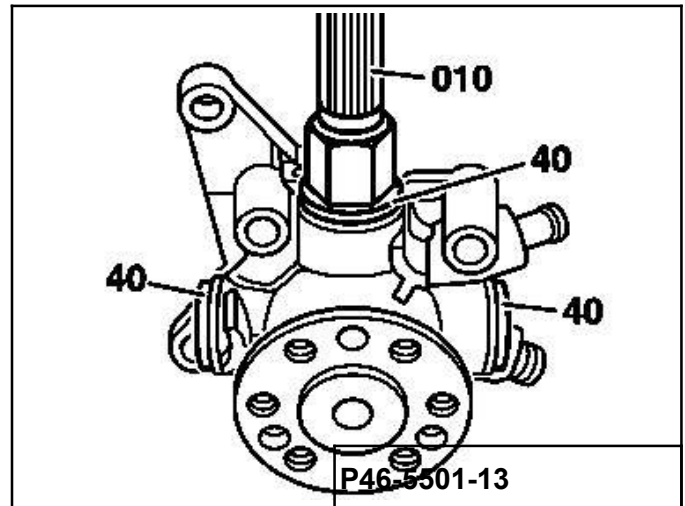

- 35 Insert thrust washer (5) and O-ring (22) into the housing. Bronze-coated side of the thrust washer (5) must be installed facing the rotor.

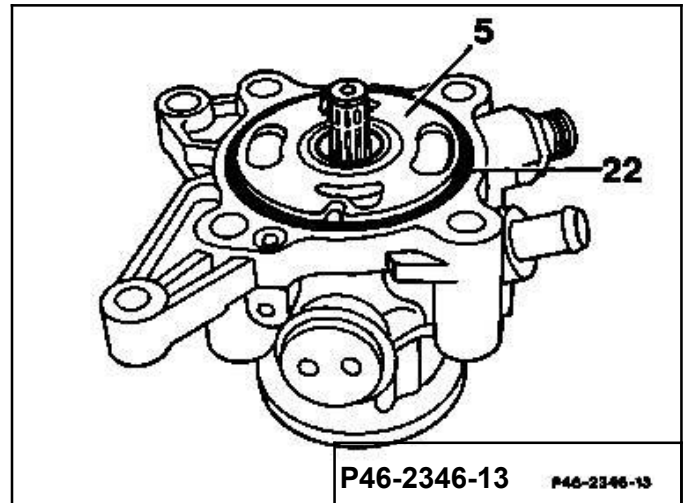

- 36 Fit rotor onto the drive shaft so that the chamfer on the inner diameter (arrow) is facing the thrust washer.

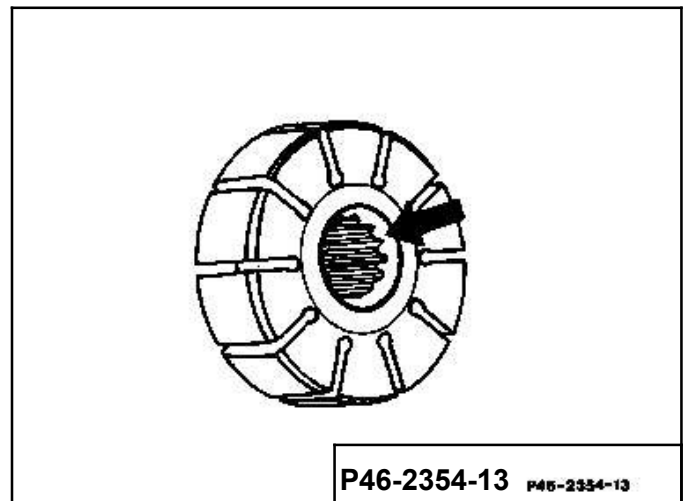

- 37 Install new locking ring (18). The locking ring (18) must be correctly seated in the groove of the drive shaft.

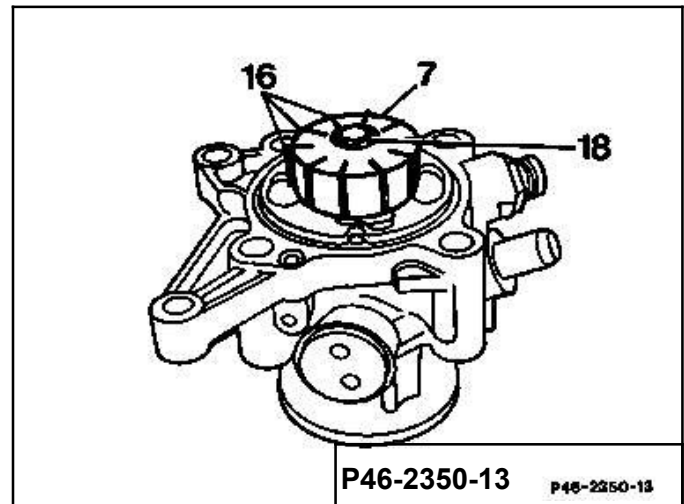

- 38 Insert vanes (10 off) into the rotor with the rounded metallic glossy sides (arrow) facing the cam insert.

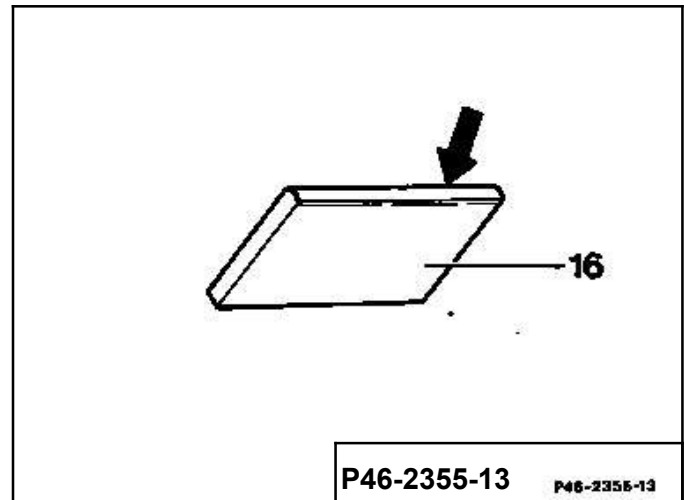

- 39 Insert straight pins (20), then introduce cam insert (6) into the straight pins with the cast direction of rotation arrow (arrow) facing upwards.

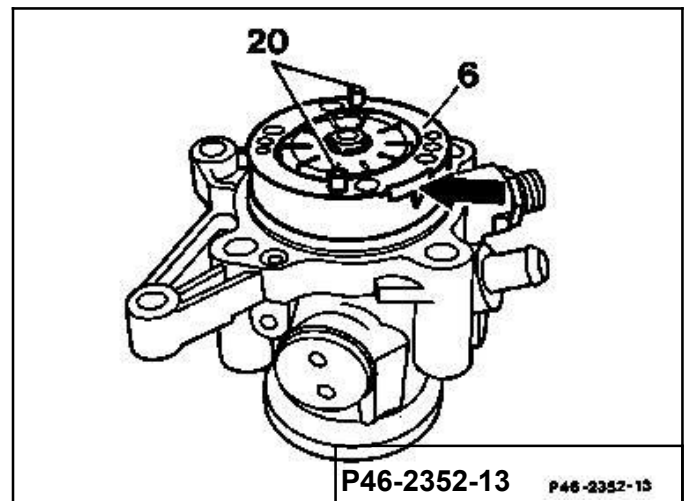

- 40 Fit pressure plate (3) with the ground face pointing toward cam insert (6).
Fit O-rings (26b) onto the pressure plate with grease.

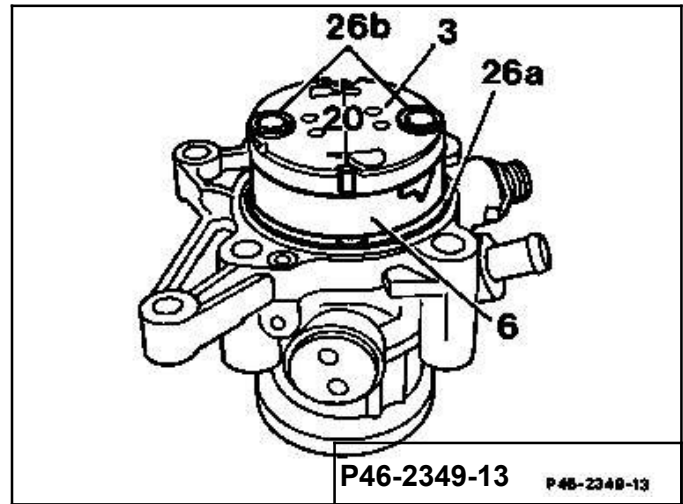

- 41 Insert bearing flange in the pump housing and attach with the hexagon bolts (25).
Tightening torque 30-35 Nm.

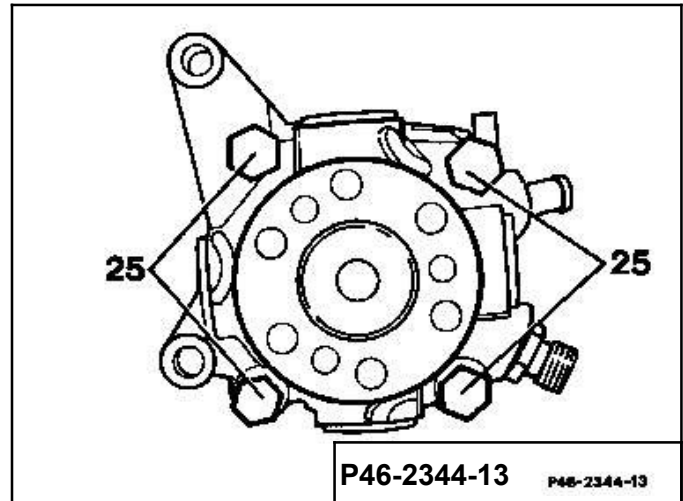

- 42 Insert new O-ring (21), then fit on fluid reservoir (35) and attach with bolts (36).
Tightening torque 8 Nm.

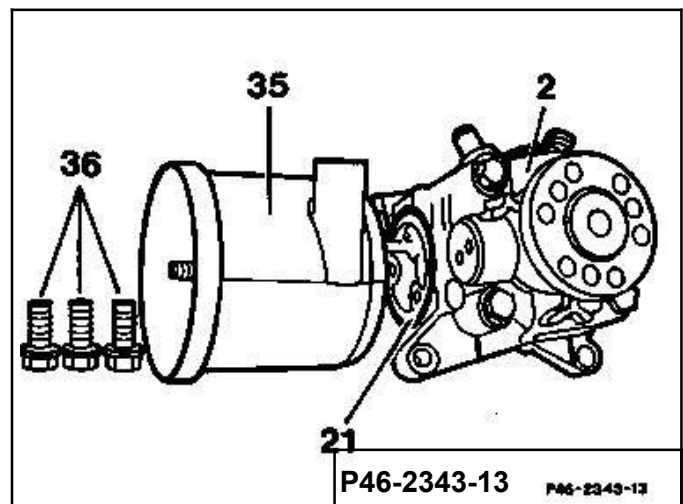

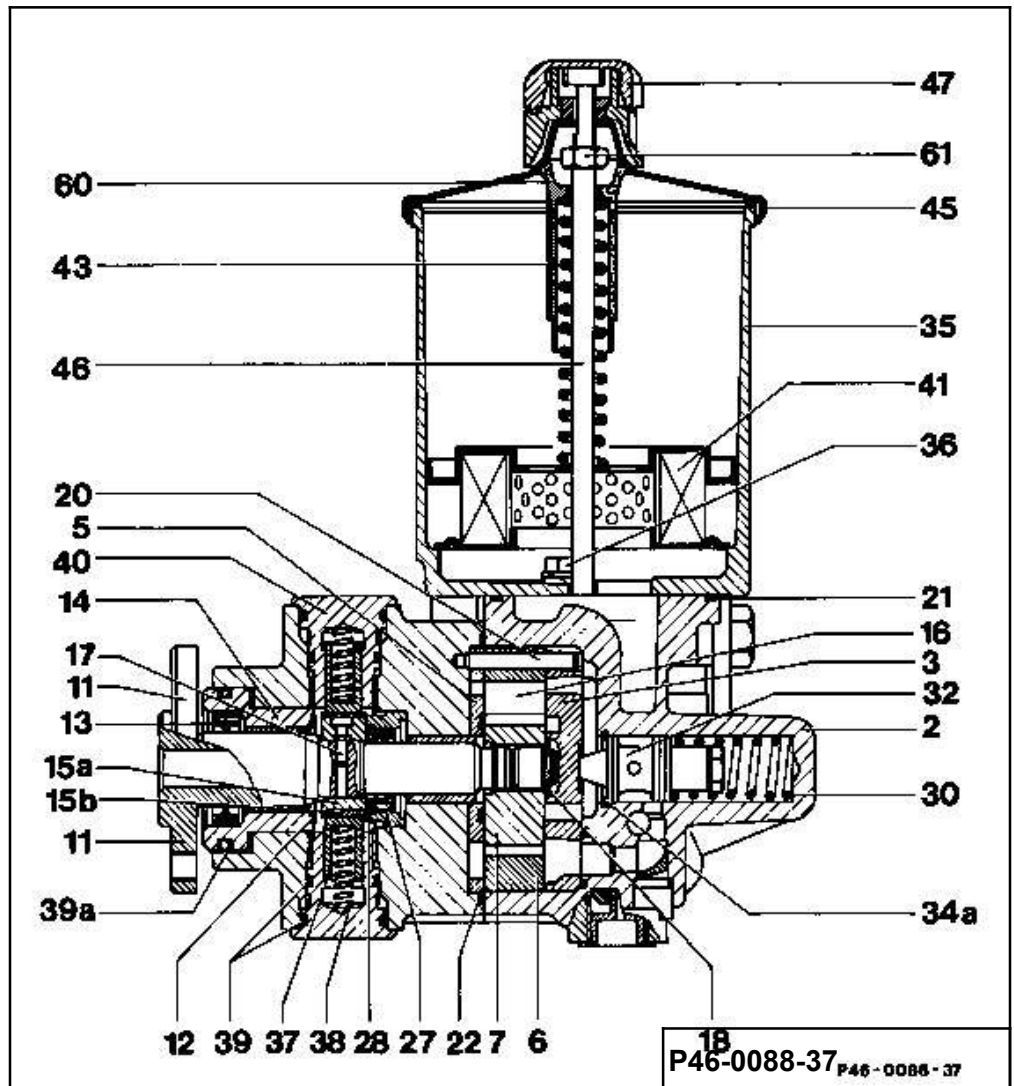

43 Insert filter set (41), spring (43) and plastic sleeve (60), compress slightly and install new self-locking nut (61). Fit on end cover (45), screw on breather cap.

44 After installing tandem pump (Operation no. 46-4000), check tandem pump for proper operation and signs of leaks. Connect pressure gauge, if necessary, and test delivery pressure of the power circuit (operation no. 46-3070). Fill or bleed systems (operation no. 46-0715).