



AP46.40-P-4650-01BA	Check tie rod and center link for play	 If play is present, replace track rod ball joints or drag link	
---------------------	--	--	--

Testing possibilities:

- Check track rod and drag link joints by pulling back and forth with force or
- move steering wheel from left to right and vice versa approx. 100 mm while having a second mechanic feel the track rod and drag link joints.

 Vehicle must be standing on wheels.

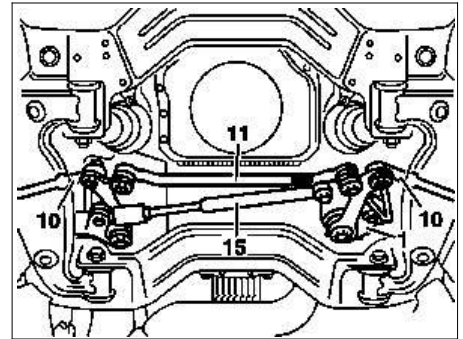

P46.40-0211-01



On model 140 the left drag link joint and on model 202, 208, 170 the right drag link joint is a pin type joint.

This prevents the drag link from tipping.

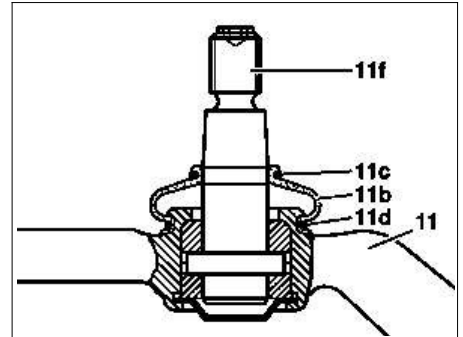

P46.00-0223-01