

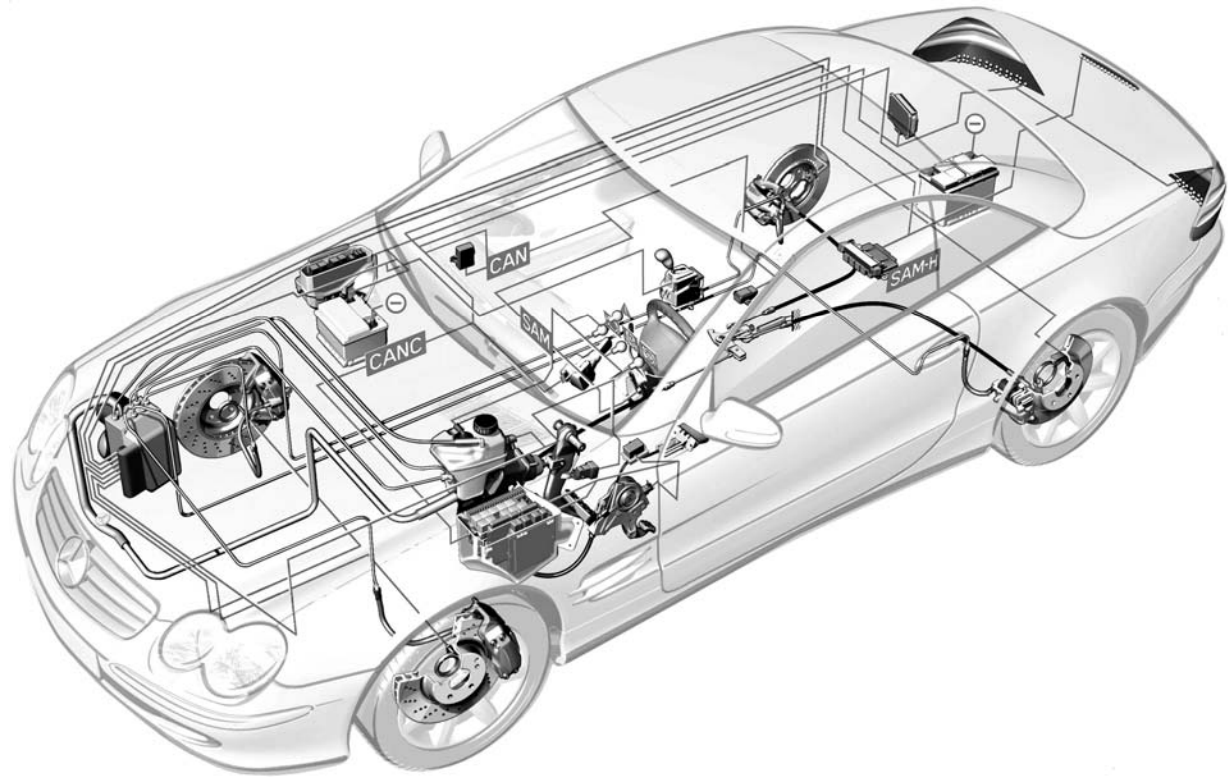

Mercedes-Benz

Sensotronic Brake Control (R230 SBC)



These technical training materials are current as of the date noted on the materials, and may be revised or updated without notice. Always check for revised or updated information.

To help avoid personal injury to you or others, and to avoid damage to the vehicle on which you are working, you must always refer to the latest Mercedes-Benz Technical Publication and follow all pertinent instructions when testing, diagnosing or making repair. Illustrations and descriptions in this training reference are based on preliminary information and may not correspond to the final US version vehicles. Refer to the official introduction manual and WIS when available.

Copyright Mercedes-Benz USA, LLC, 2002

WIS document numbers shown apply to WIS Version G.04.06 11/01 USA/CDN

Reproduction by any means or by any information storage and retrieval system or translation in whole or part is not permitted without written authorization from Mercedes-Benz USA, LLC or its successors.

Published by Mercedes-Benz USA, LLC

Printed in U. S.A.

Index

Introduction	4
Advantages	5
Components	8
Warning Display	10
Brake Operating Unit (BOU)	12
Pedal Value Sensor	14
Hydraulic Unit (A/3)	18
Emergency Operation	19
Pressure Supply	20
ABS Control	21
ASR, EBR, ESP Functions	22
Temperature Compensation	23
Wake-up	24
Predrive Check (PDC)	25
Delayed Off	26
Deactivation	27
Activation	29
Warning Buzzer	30
Bleeding the system	31
Acronyms	32

Evolution!

ABS (Anti lock Brakes 1984)

+ ASR (Automatic Slip Regulation 1991)

+ ETS (Electronic Traction System 1994)

+ ESP (Electronic Stability Program 1996)

+ BAS (Brake Assist System 1998)

= SBC (Sensotronic Brake Control 2002)

SBC = Sensotronic Brake Control, the next level of
brake control !

Advantages of SBC

- Improves metering of required brake pressure
 - each wheel can be precisely controlled
- Improved BAS function
 - monitors release of accelerator pedal & application of brake
 - maximum pressure available immediately
 - Pre-filling of system (overcoming play)
 - when the BAS function is anticipated (identified by the rapid release of the gas pedal), slight pressure is applied

Advantages of SBC

- Optimal brake force distribution front to rear and side to side (EBP)
 - allows brake proportioning front to back and side to side
- No pedal vibration during ABS operation
 - eliminates “distraction” to the driver during critical moments
 - indicator light in speedometer signals traction loss
- Improved driving dynamics: ABS, ASR, and ESP
 - faster response to brake request inputs

Advantages of SBC

- Softstop function
 - comfort feature
 - reduces brake pressure when coming to a stop (<.6 mph)
- Pressure reduction at standstill
 - reduces stress on components
- Dry braking function
 - wiper input via CAN
 - ~every 7 to 14 minutes
 - brake actuation changes time interval



SBC Components

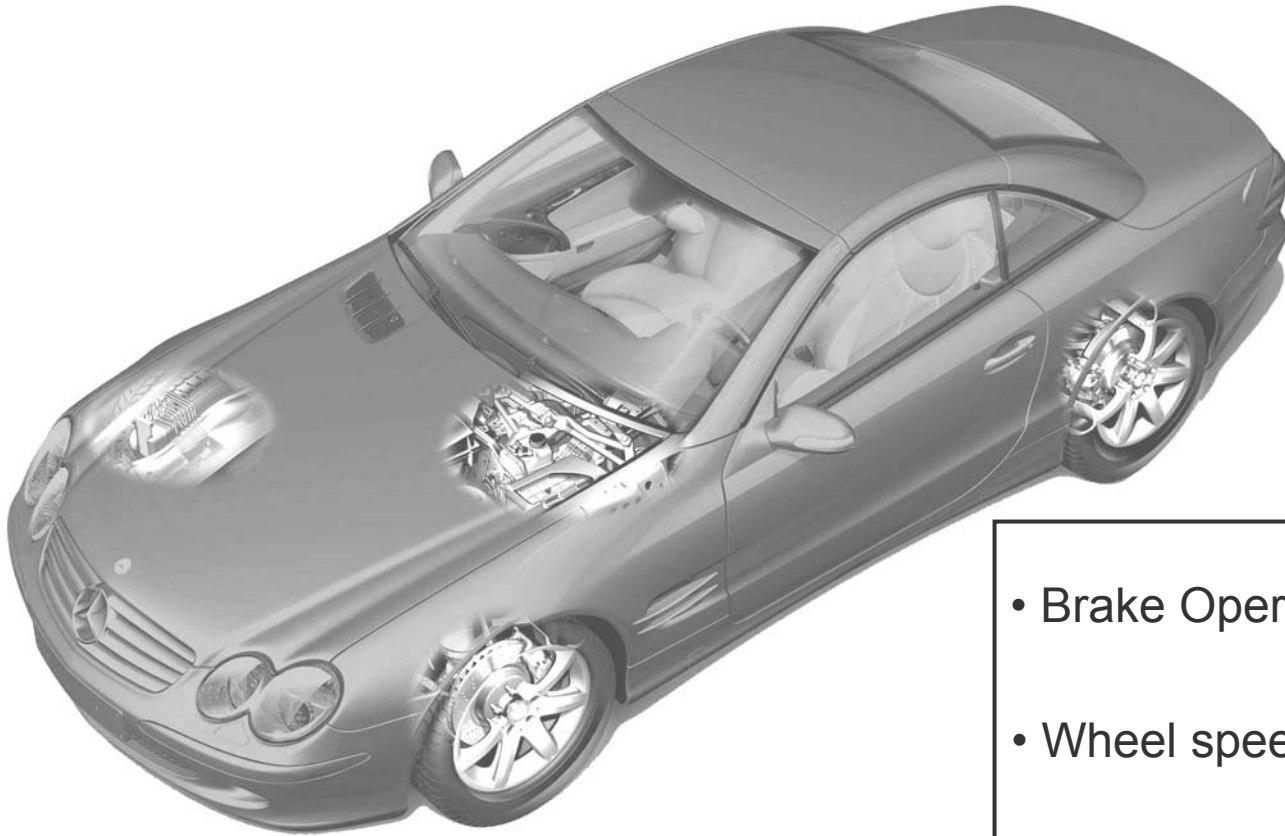

- Brake Operating Unit (BOU)
- Wheel speed sensors
- Traction System Hydraulic Unit A7/3

Wear Sensors

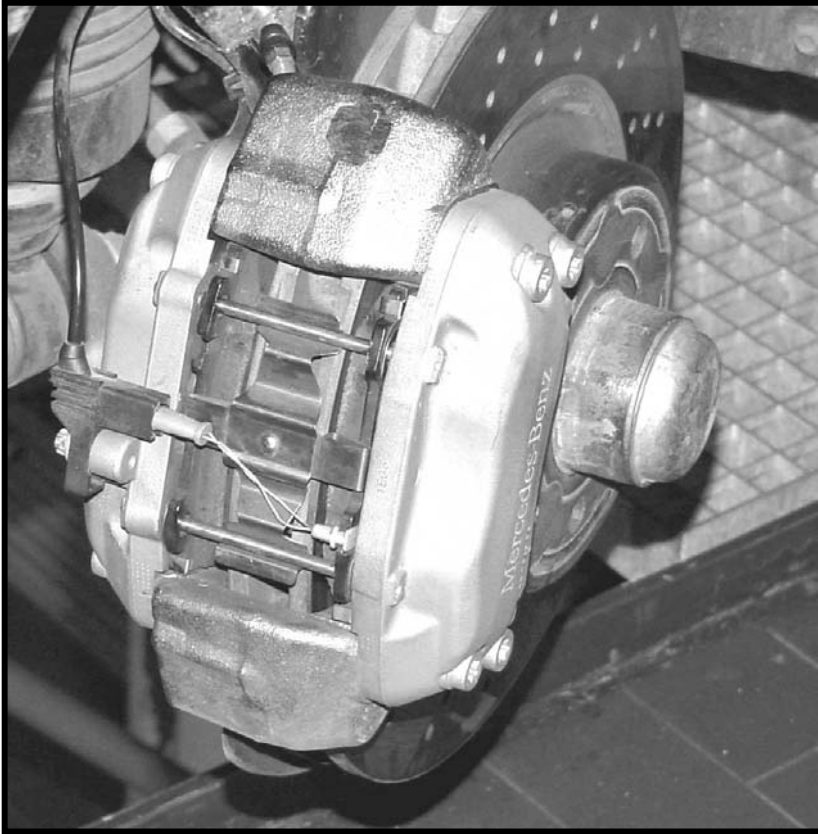

Three brake pad wear sensors connected to closest SAM

- Left front (S10/1)
- Right front (S10/2)
- Right rear (S10/4)

Warning Display

ESP control module failure

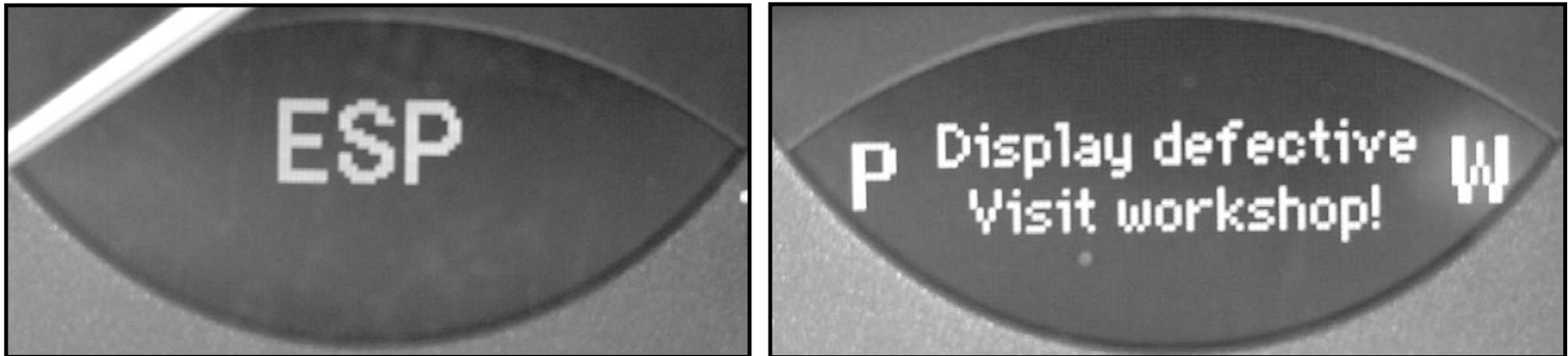

If the ESP control module has a complete failure the dash will cycle through it's displays (ABS, BAS, ESP). The SBC system is still functional but without any pressure modification including brake proportioning.

Depending on the failure, all other systems that require a vehicle speed signal with also be in-operative. (Transmission in second gear, no SPS steering , etc.)

Warning Display

SBC control module failure



If the SBC system shuts down, you default to the emergency braking mode, all vehicle speed related functions may also stop depending on the failure. Certain faults will trigger an audible signal.

Brake Operating Unit - (BOU)

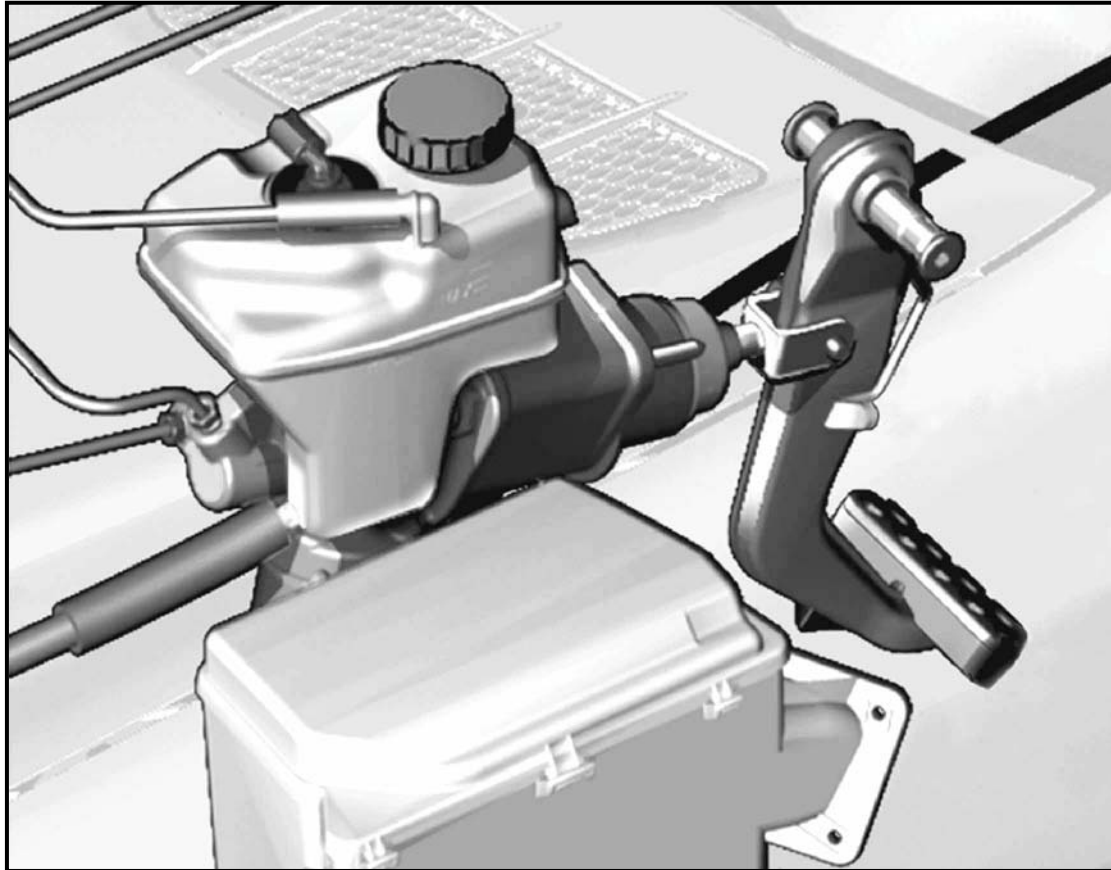

Brake Operating Unit

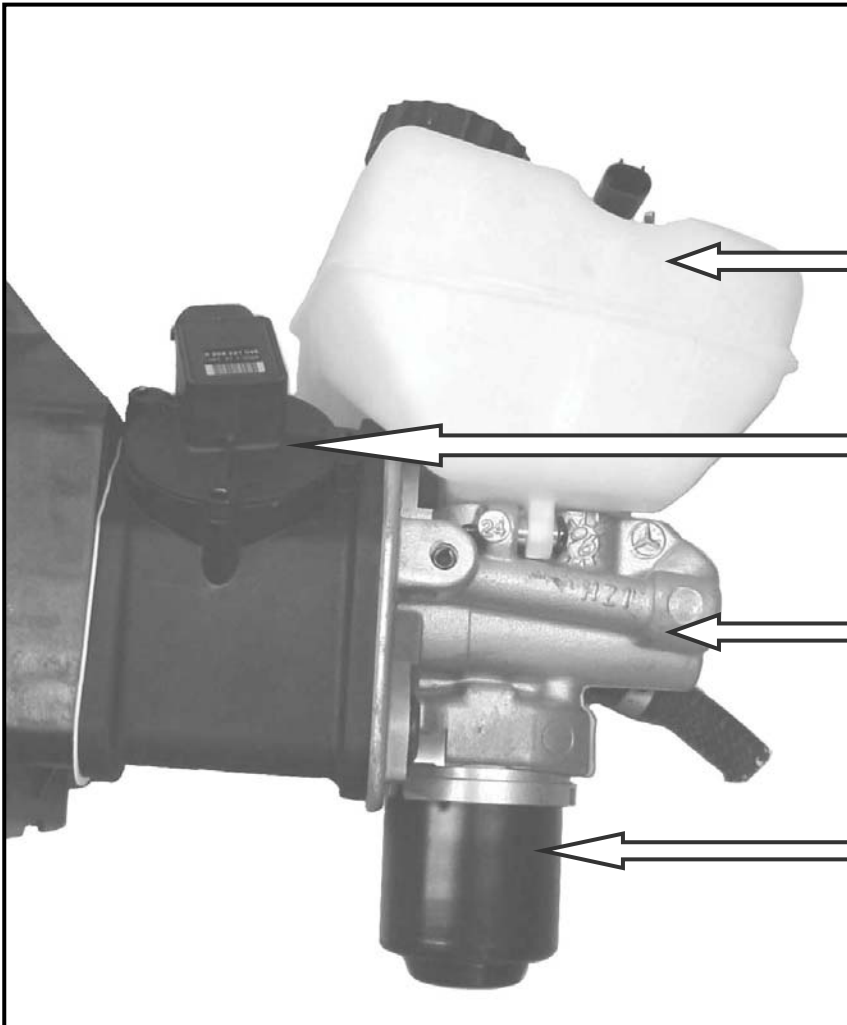

The Brake Operating Unit (BOU) consists of the following:

- Brake fluid reservoir
(Do not overfill!)
- SBC pedal value sensor (B37/1)
- Tandem master cylinder
- Brake pressure simulator

Pedal Value Sensor - B37/1

- Contains two hall effect sensors
- Converts pedal travel to electrical signal
- Provides input to SBC control module A7/3

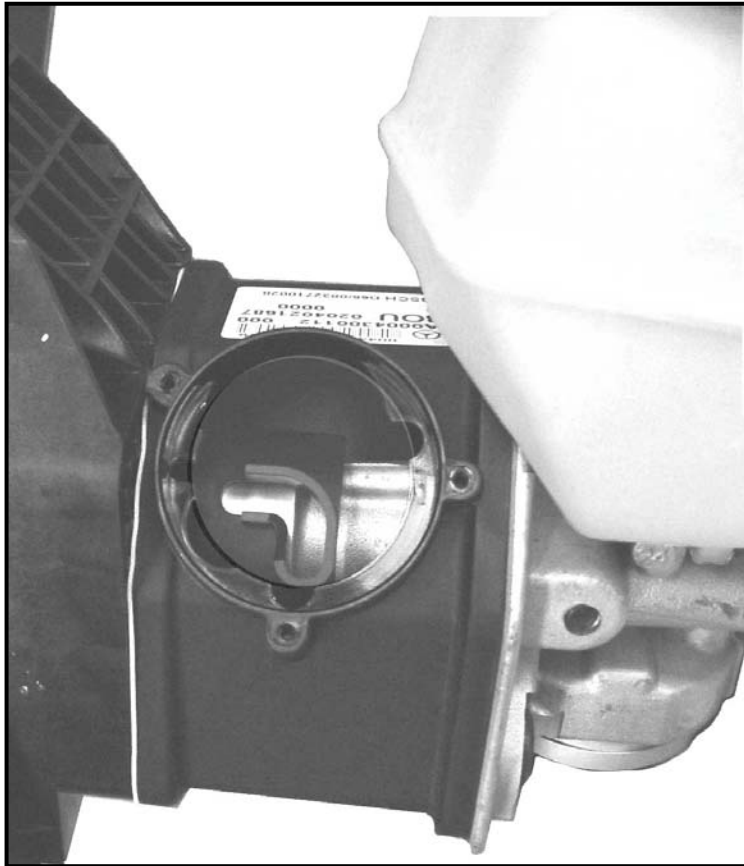

BOU Tandem Master Cylinder

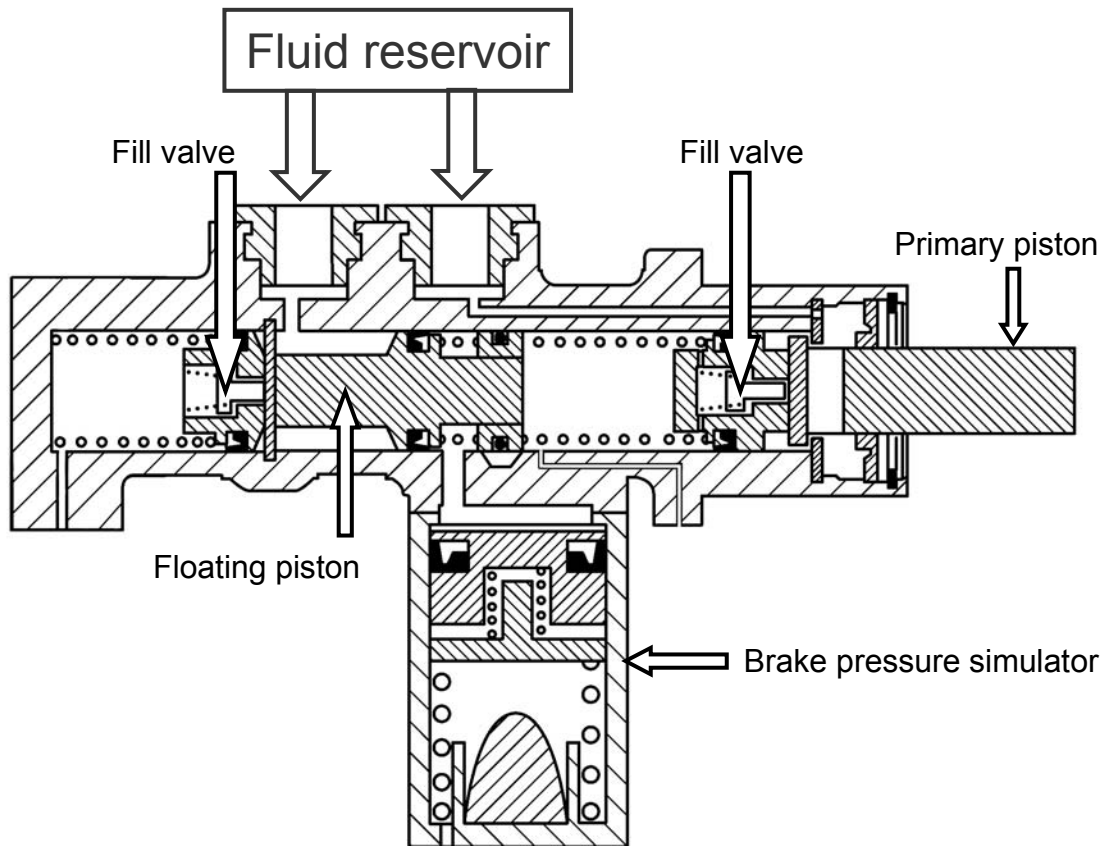

The fill valves open against the small spring pressure, allowing the fluid from the reservoir into the body of the master cylinder. When the pedal is depressed, the fill valves seat and prevents the fluid from returning to the master cylinder reservoir.

The floating piston and the primary pistons perform the same functions as in a normal master cylinder, that is to create pressure at the outlet ports.

The brake pressure simulator is used to provide feedback to the driver.

BOU Tandem Master Cylinder

The outlets ports are connected to A7/3 (SBC hydraulic unit), which contains separation valves y1 and y2.

When the travel sensor moves ~2mm, a brake request signal is sent to A7/3.

A7/3 y1 and y2 are activated and separate the master cylinder from the rest of the brake system during normal operation.

When y1 and y2 are energized, the fluid cannot move from the master cylinder, therefore the floating piston compresses the fluid in the simulator chamber causing a counter pressure that the driver interprets to be normal brake pressure feel.

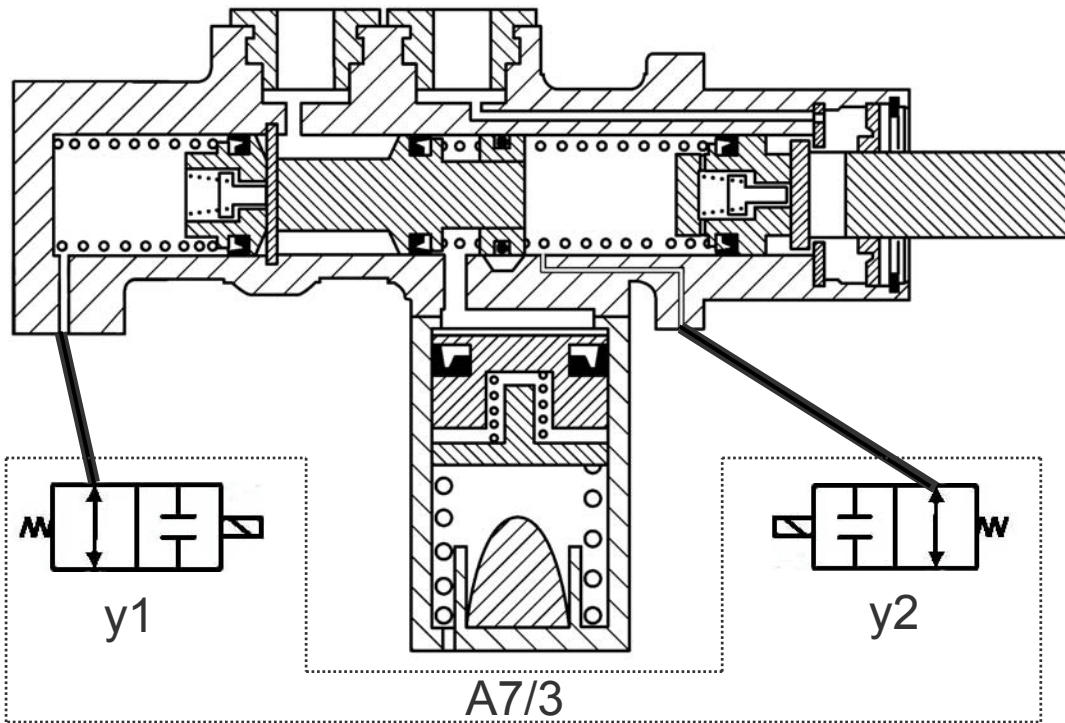

Emergency Operation

In the event of a SBC system failure the front brakes are braked hydraulically by the brake pedal without power assist.

In this case both separation valves are de-energized, allowing the brake pressure to go to the calipers of the front wheels.

This system meets the legally mandatory minimum deceleration of 0.3 g with a foot pressure of 500 N. (112lb/ft)

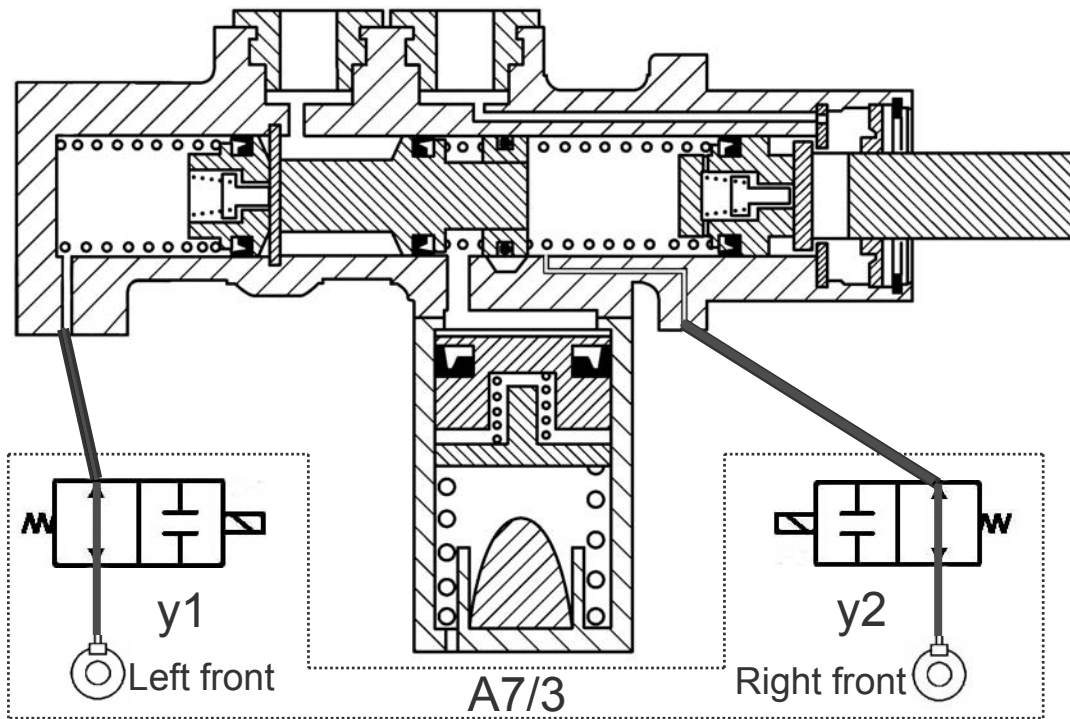

Traction System Hydraulic Unit A7/3

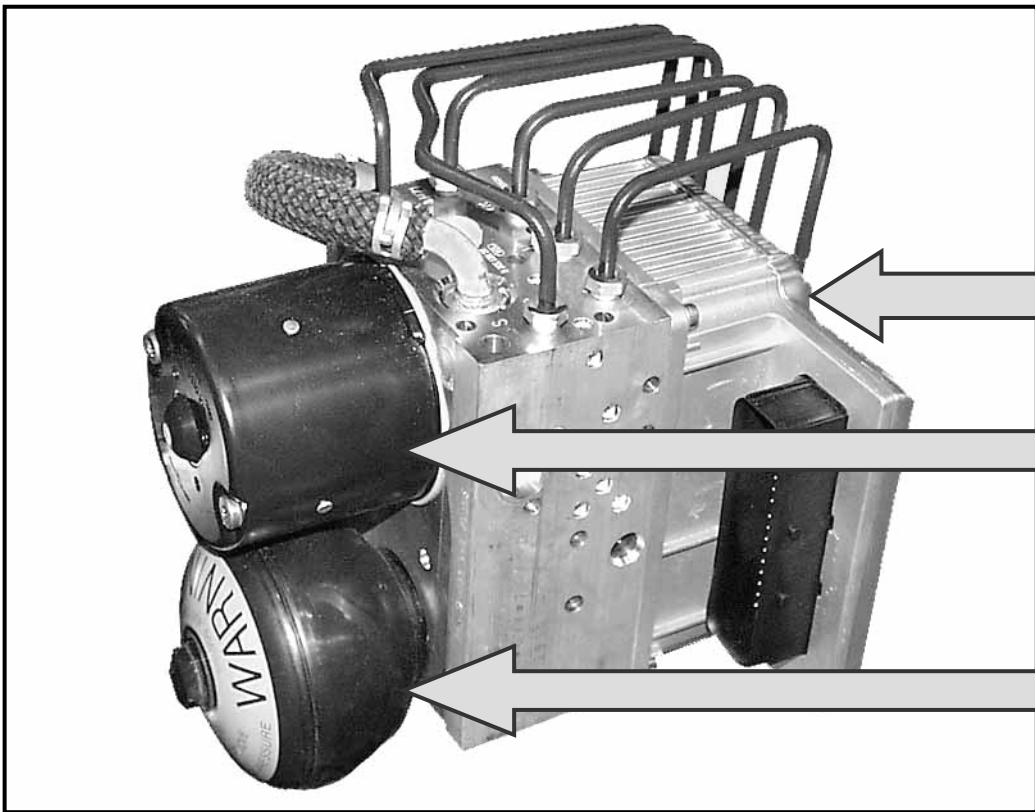

Consists of:

- SBC control module (A7/2n1)
- High pressure charge pump (A7/3m1)
- Pressure reservoir

Emergency Operation Circuit

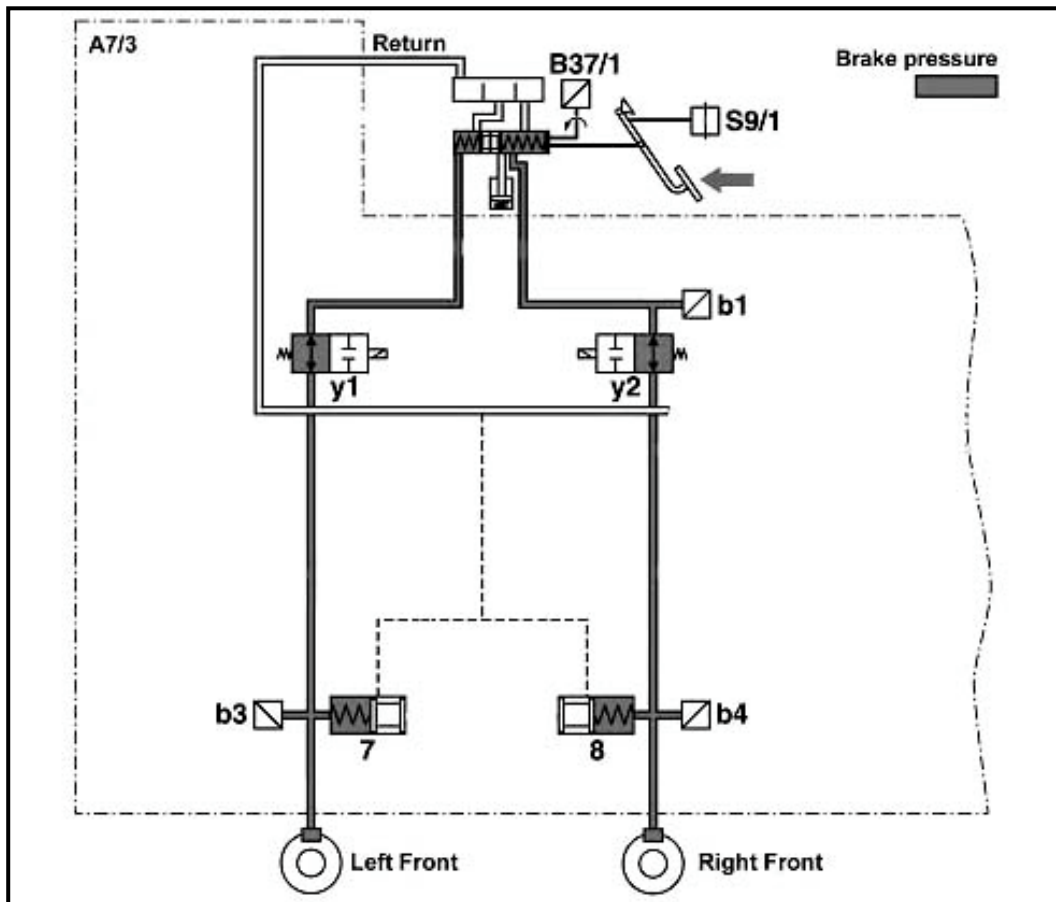

A7/3b1, b3, and b4 are pressure sensors that provide information to the SBC control module.

The left front dividing piston (7) and right front dividing piston (8) are used to isolate the emergency circuit from the electronically controlled circuit.

The pistons are double sealed with the dotted line representing that the brake fluid would return to the reservoir in the event of a seal failure.

During the emergency operation, the pistons have reached their maximum travel so that the caliper pistons will apply the pressure to the rotors.

Brake Pressure Supply

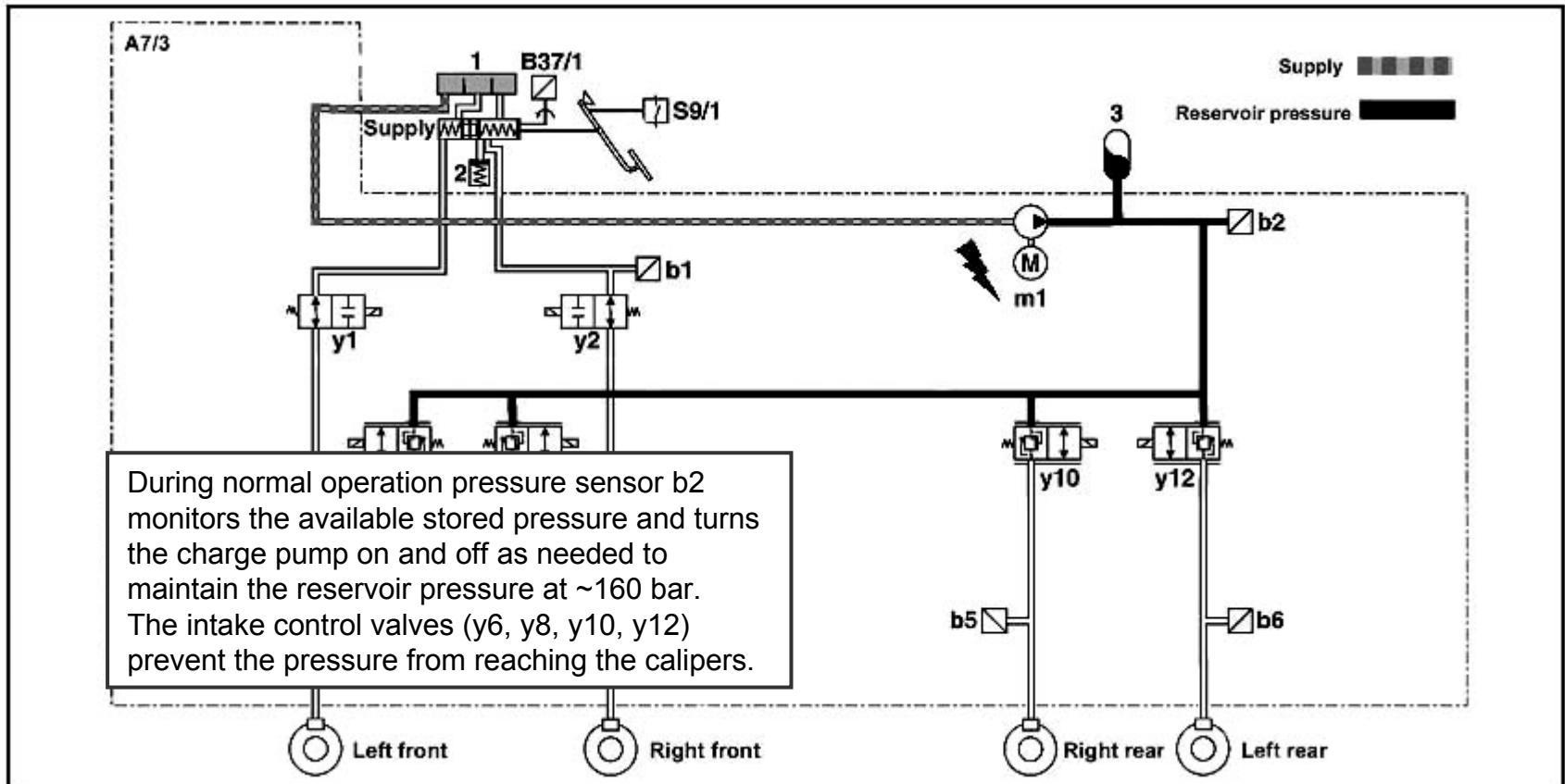

ABS Control

ABS - prevents the wheels from locking up during braking, maintaining steerability and directional control during deceleration

ASR, EBR and ESP Functions

ASR (braking moment) - prevents drive wheel from spinning while driving.

EBR - reduces brake slip at the drive wheels during deceleration to ensure directional control.

ESP - prevents the vehicle from breaking away when oversteering or understeering.

The major difference between any of these modes and the normal braking or ABS mode is the fact that the driver has not operated the brake pedal, the ESP control module (N47/5) has initiated the pressure request.

EBR is actually a function of E-Gas. (It is mentioned here as a review of the system function even though A7/3 is not hydraulically involved.) When engine braking causes the rear wheels to reduce speed quicker than the front wheels (causing the rear of the vehicle to slide), the throttle is opened slightly to reduce the engine braking affect.

Temperature Compensation

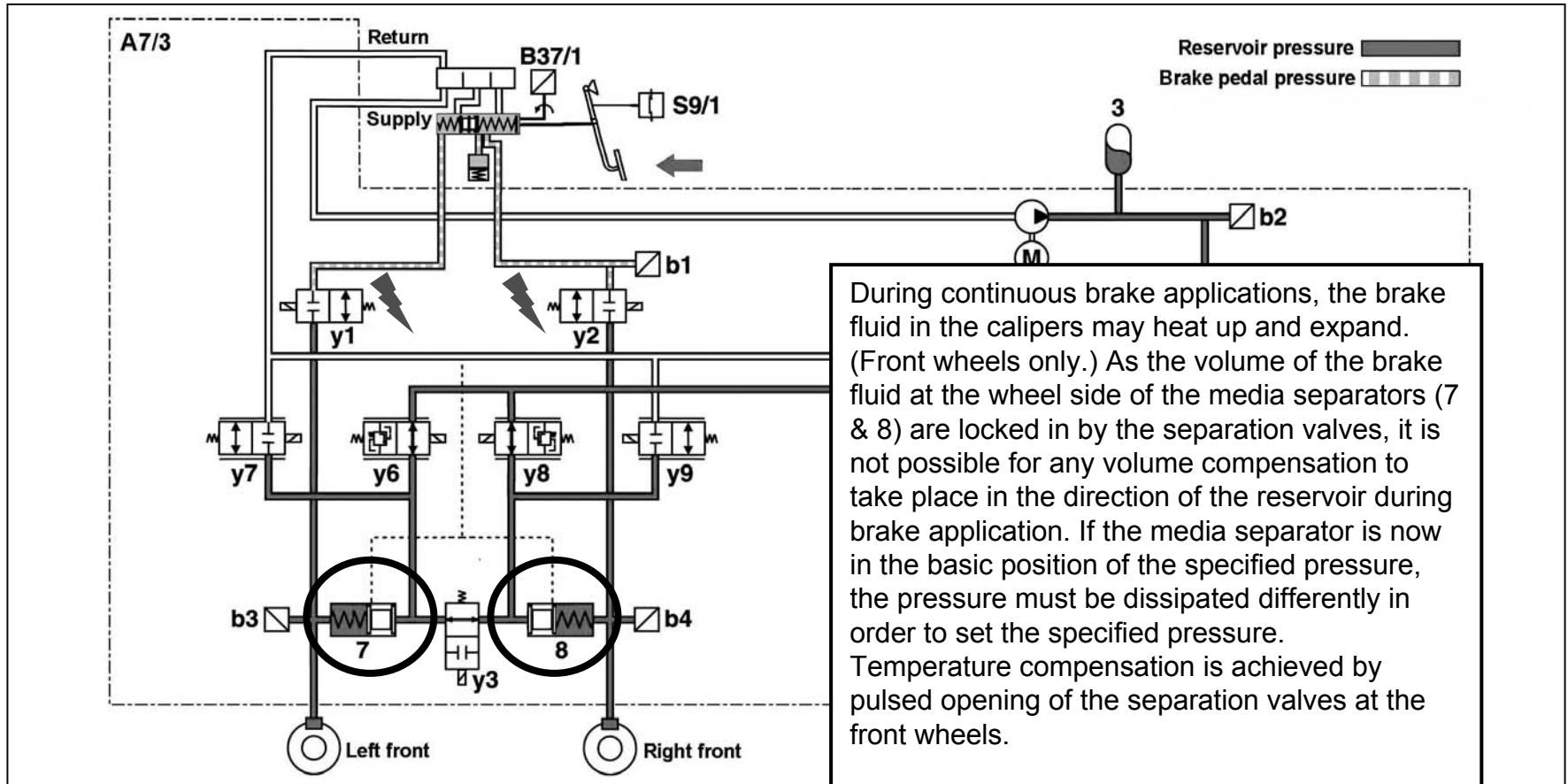

During continuous brake applications, the brake fluid in the calipers may heat up and expand. (Front wheels only.) As the volume of the brake fluid at the wheel side of the media separators (7 & 8) are locked in by the separation valves, it is not possible for any volume compensation to take place in the direction of the reservoir during brake application. If the media separator is now in the basic position of the specified pressure, the pressure must be dissipated differently in order to set the specified pressure. Temperature compensation is achieved by pulsed opening of the separation valves at the front wheels.

Note: The driver may notice the brake pedal pulsating during this operation.

Waken-up

SBC is functional as soon as it is “wakened” by:

- opening a door (from N10/8)
- operating the central locking system (from N10/8)
- depressing the brake pedal
- turning the key to position 1
- releasing the parking brake

The wake up signal comes from the left front SAM

Predrive Check (PDC)

SBC may perform a PDC after waking, the following are checked:

- reservoir pressure (and corrected if necessary)
- pressure sensors (~ 60 bar of pressure applied to each wheel)
- control valves
- leak tests
- operational checks

The PDC is cancelled if the driver operates the accelerator.

Self-test of the separation and balance valves are constantly conducted during driving. (About every 16 brake applications.)

Delayed Off Function

Time that SBC remains operational after use:

- with vehicle stationary and was locked = 20 seconds
- with vehicle stationary and ignition in “0”,
brake pedal not operated = 2 minutes
- with vehicle stationary, ignition in “0”,
brake pedal operated in delayed off phase
and released again = 4 minutes

Deactivation

Before working on the system it must be deactivated to prevent possible injury.

Deactivating the system will:

- empty the pressure reservoir
(a lower pressure with no volume may be retained)
- prevent the charge pump from operating

Note: the warning buzzer is deactivated when accessing SBC with the SDS.

Deactivation

SBC must be deactivated *PRIOR* to:

- working on the hydraulic system
- removing or installing brake pads
- replacing rotors
- replacing the pressure reservoir
- replacing the BOU
- replacing the SBC hydraulic unit (A7/3)

System Activation

Activation must be performed anytime the system has been deactivated, *BEFORE* the car is started!

Failure to activate will prevent proper operation and create fault codes!

Activating SBC will:

- charge the accumulator
- move the pads towards the rotors with ~60 bar pressure
- erase the fault memory
- perform a Predrive Check

(Note: may have to activate several times to position the brake pads)

Bleeding the Brake System

Proper system bleeding is critical!
Follow directions in SDS

- Bleeding must be performed using the SDS
- Pressure at bleeder valves will exceed 100 bar
(Hold the bleeder hose securely)
- Bleeding may require ~1.5 hours
- Bleeding may use ~ 1.5 liters of brake fluid

Acronym List

(Used in This Handout.)

ABS - Anti-lock Brake System

ASR - Anti Slip Regulation

BAS - Brake Assist System

BOU - Brake Operating Unit

CAN - Controller Area Network

EBP - Electronic Brake Proportioning

EBR - Electronic Brake Regulation

E-Gas - Electronic Accelerator

ESP - Electronic Stability Program

ETS - Electronic Traction System

PDC - Predrive Check

SAM - Signal Acquisition Module

SBC - Sensotronic Brake Control

Legend

AR42.10-P-0012R	Bleeding Brake System with SDS
GF42.45-P-0001-04SL	ESP driver information
GF42.45-P-0001SL	ESP function
GF42.45-P-2000SL	ESP brake moment control
GF42.45-P-3500SL	ASR control mode function
GF42.46-P-0001SL	SBC function
GF42.46-P-1000SL	SBC Normal braking function
GF42.46-P-2000SL	SBC additional braking functions
GF42.46-P-3000SL	SBC braking with malfunction
GF42.46-P-4200-03SL	BOU function
GF42.46-P-4210SL	SBC pedal value sensor
GF42.46-P-4500-02SL	SBC control module – task
GF42.50-P-4000-03S	Hydraulic unit design
GF42.50-P-4000-04S	Hydraulic unit function
GF42.50-P-4000S	Hydraulic unit task/location/function