

WF58.50-P-3530-01A	Shell halves (2 ea.) for pressing off and caulking the inner constant velocity joint.	Model 129, 140, 166, 170, 171, 172, 202, 203, 204, 207, 208, 209, 210, 211, 212, 215, 216, 218, 219, 220, 221, 230	WF
--------------------	---	--	----

1 Shell halves (2 ea.) for pressing off and caulking the inner constant velocity joint.

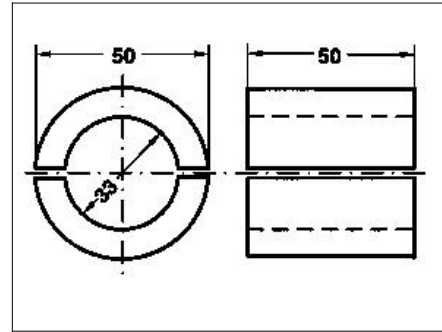

P35.30-0223-01