

This site uses cookies to help deliver services. By using this site, you agree to the use of cookies.

[Learn more](#)

[Got it](#)

Mercedes Benz ABC System Troubleshooting Guide

Sunday, August 24, 2014

ABC System

Welcome to my writeup for the Mercedes Active Body Control (ABC) Suspension System.

In July of 2014, I purchased a used 2003 Mercedes SL500 with 80,000 miles on it. And within days the infamous "ABC Drive Carefully" message started appearing on the dash. That was my introduction to the ABC system. Like many of you reading this post now, I was shocked to learn how unreliable this system is and how expensive it is to repair. I decided that if I was going to keep the SL500, then I was going to become an expert in this system, and be prepared to do many of the repairs myself in order to keep the maintenance costs under control.

I've spent countless hours reading message board discussions and finding diagrams on the ABC system. What follows is what I have learned so far. I am publishing this in the hopes it will save others hours of reading message board posts to understand what is going wrong with their system, and give some advice on what to do when problems occur.

Trouble Shooting Summary:

Here is a cheat sheet to help determine the cause of a problem and what action to take. If you aren't interested in how the system works and just want to know what to do, this table should suffice.

The remainder of this document will give you details on how each component of the system works, how to recognize when they fail, and what courses of action to fix them. There is also advice on how to reduce the ownership costs related to the ABC system, how to maintain it, and other valuable information.

Symptom	Cause	Action to Take
"Drive Carefully" or "Visit Workshop" appears for a few seconds when hitting a bump or dip in the road. This may or may not be accompanied by fluid overflowing from the reservoir.	One or more of the accumulators has failed and is no longer supplying pressure to help fill the struts when needed.	Pull and inspect the front and rear axle accumulators - each are part number 2203270115 (the large ones). Replace as necessary. Given these accumulators only cost about \$150 each, you should seriously consider just replacing them regardless of what you find, as a preventative maintenance investment.
One or more corners of the car sags or lowers when parked.	Assuming there are no puddles of hydraulic fluid on the garage floor, then this is a dirty valve block. Usually gunk has built up on the seats of the valves (the shut-off valve in particular) preventing a good seal, so fluid leaks out of the strut and goes back to the return	The first action is to change the ABC fluid filter, perform a procedure called a "rodeo" that exercises the system, and then replace the filter again. This will sometimes clear up the problem, at least temporarily. This will cost around \$300. If the fluid is old, you should strongly

About Me

[Darren B](#)

[View my complete profile](#)

Blog Archive

▼ [2014](#) (1)

▼ [August](#) (1)

[ABC System](#)

	<p>reservoir.</p> <p>It is also possible the o-rings in the valve have deteriorated.</p>	<p>consider having it flushed, which will cost another \$200.</p> <p>If the filtering fails, and if you are capable of DIY repairs, then there are write-ups showing how to pull these blocks and clean them. It is also a good idea to replace the o-rings just in case one of them is the cause. Cost for this procedure is less than \$100. Results vary.</p> <p>You last option is to have the valve block replaced. This will cost around \$2,000, or around \$1,250 if DIY.</p>
<p>"Drive Carefully" or "Visit Workshop" appears on the dash every time you start the car and stays on. It never goes away</p>	<p>There is a malfunction in the ABC system somewhere. The ABC system noticed a problem when starting up and has disabled itself, locking the struts in their current position. Depending on how low the struts are, this may result in what many people describe as a "tuna boat" ride.</p> <p>Possibilities are:</p> <ol style="list-style-type: none"> 1. A loose connection to a sensor 2. A sensor has failed 3. The pump has failed 4. The system has a fluid leak causing a loss of fluid, preventing the system from getting up to operating pressure. 	<p>Check the underside of the car for any signs of fluid leak.</p> <p>Check the fluid levels in the reservoir. If empty do not attempt to start or drive the car. If you run the pump dry it will be ruined...a \$2,500 repair! Go the parts store for a quart of "Pentosin CHF 11S" fluid and fill to the upper mark before starting the engine.</p> <p>If the system is unable to hold it's fluid long enough for a drive to the workshop, then have the car towed.</p> <p>Take the car to the dealer or a workshop with a Mercedes STAR diagnostic system (SDS). If the problem is not leak related, then you will need the diagnostic codes to determine what component is having the problem.</p> <p>The remainder of this document has advice on where to go from there.</p>
<p>"Drive Carefully" or "Visit Workshop" comes on the dash and stays. Stopping and starting the car sometimes resets things back to normal for a while.</p>	<p>Possibilities are:</p> <ol style="list-style-type: none"> 1. The pump is weak, resulting in inconsistent performance. Sometimes the ABC system reaches operating pressure, sometimes not. 2. A strut travel sensor may be going bad. Some strut motion 	<p>Take the car to the dealer or a workshop with a Mercedes STAR diagnostic system (SDS). It will have diagnostic codes indicating the problem.</p> <p>If it is the pump, low pressure error codes will have been logged.</p> <p>Confirm by</p> <ol style="list-style-type: none"> 1. Rule out accumulators with SDS diag test

	from driving gets it working again.	<p>2. Monitoring pressure during a rodeo. If it can make it through the rodeo without the pressure dropping below 100 bars, the pump is fine.</p> <p>A strut sensor problem will have error codes logged for it as well.</p>
You hear a loud bang, and the "Drive Carefully" message comes on the dash shortly after.	A hose has blown, and the system has run out of fluid.	<p>Pull over and shut off the car immediately. Check for leaks under the vehicle (they may be masked by the plastic panels covering the underside). Check the fluid level in the reservoir. If empty do not start or drive the vehicle. Doing so will ruin the pump. Have the car towed to a repair shop.</p>
You can hear a hum or whine under 2000 rpm. Is present both in gear and out of gear.	The pulsation dampener has worn out.	<p>There are lots of pumps and other non-ABC components that produce noises like this on these vehicles, so try to locate the source of the noise using a stethoscope or long screwdriver.</p> <p>The ABC component most likely to cause this noise is the pulsation dampener. The location varies by model. On the R230 it is located in the front-left wheel well. Other models will have it attached to the undercarriage near the transmission.</p> <p>Replace the dampener. Cost is around \$175 and is a relatively simple DIY project. Or around \$600-800 if you have a shop do it.</p>

ABC System Overview

The ABC system can be found predominantly on the following Mercedes models.

R230 SL Class (2003-2012 : SL320, SL500, SL55 AMG, SL600, SL65 AMG)

W215 CL class (2000-2006 : CL500, CL600, CL55 AMG)

The system consists of the following components:

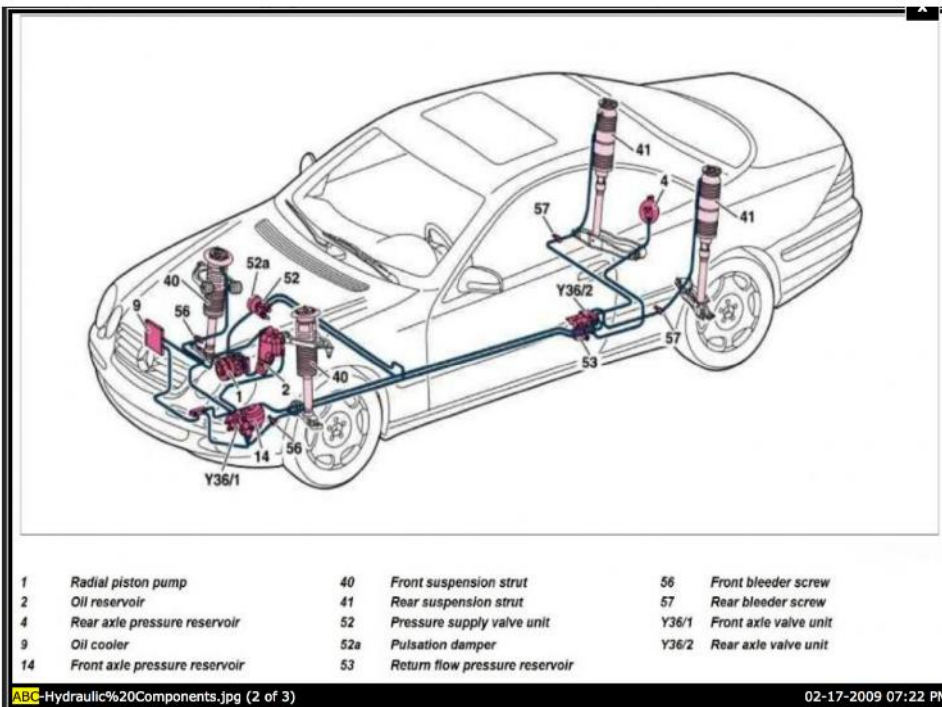

Component	Purpose
ABC Control Module	Controls the system.
Pump	Supplies hydraulic pressure for the system
Pulsation Dampener	Smoothens out the pressure from the pump (P/N 2203270215)
High Pressure Check Valve	Regulates system pressure at 190 bars
Pressure Sensor	Reports the system pressure to the control module
Front Axle Valve Block	Controls letting fluid in and out of the front struts, based on commands from the control module
Rear Axle Valve Block	Controls letting fluid in and out of the rear struts, based on commands from the control module
Front Axle Accumulator	Stores fluid and pressure for the front struts, assisting the pump by supplying the on-demand pressure needed to fill the front struts. (P/N 2203270115)
Rear Axle Accumulator	Stores fluid and pressure for the rear struts, assisting the pump by supplying the on-demand pressure needed to fill the rear struts. (P/N 2203270115)
Struts	Connects the chassis to the wheels and the coil spring inside absorbs vibration. Pumping hydraulic fluid into the strut stiffens the spring and raises the vehicle.
Return Accumulator	Evens out the pressure on the return side of the hydraulic system (once the fluid leaves the struts) (P/N 2203270415)
Return Pressure Check Valve	Regulates the return side pressure at 10 bars
Oil cooler	A small radiator that cools the hydraulic fluid
Reservoir	Stores extra fluid for raising the ride height and pressurizing the accumulators and replacing any leaked fluid.
Strut position sensors	Reports to the control module the position of each strut
Ride height sensors	Reports to the control module how high each corner is
Motion sensors	Reports to the control module what the car is doing motion-wise

ABC System Design

Pictured below is the schematic for the hydraulic portion of the ABC system. I've found this diagram to be the most informative of any of the diagrams out there on the ABC system. Taking time to understand this diagram is key to understanding how the ABC system works.

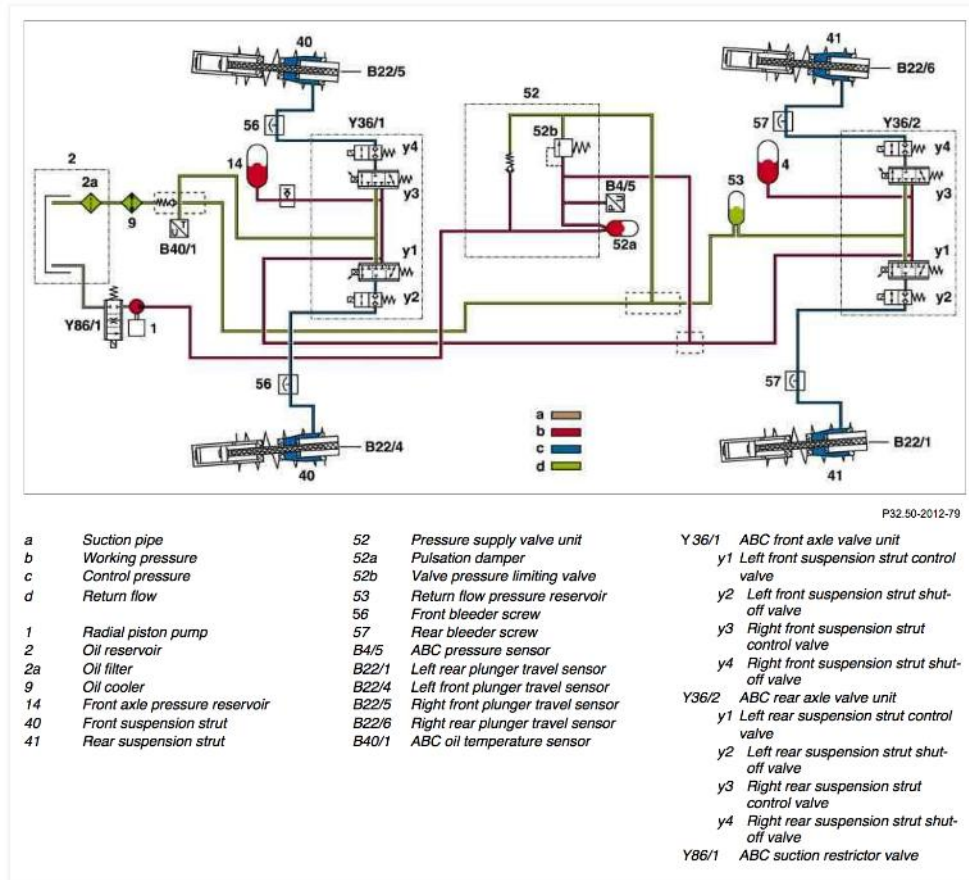

Going on a brief tour of the diagram...the ABC fluid starts its travel at the fluid reservoir(2). From the reservoir it is drawn into the pump(1). The pump pushes the fluid to an assembly(52) containing a pulsation dampener(52a) that reduces vibration, a check valve (52b) that regulates the pressure at 190 bars, and a pressure sensor (B4/5) that reports the pressure to the control module. From there the fluid travels to the two valve blocks(Y36/1 and Y36/2) that control the struts(40,41). Accumulators(4,14) are attached to each valve block to store fluid and pressure for filling the strut. The control module commands the valves to open or close which allows fluid to enter or leave the struts. When the fluid leaves the struts, it travels through a temperature sensor(B40/1), a check valve(not shown) that regulates the return pressure at 10 bars, and then through the oil cooler(9) and back to the reservoir(2). An accumulator (53) helps even out the spikes in the return side pressure caused by the struts letting out fluid.

There is also the electronics side of the design.

32.50 Active body control (ABC), Location of electrical/electronic components

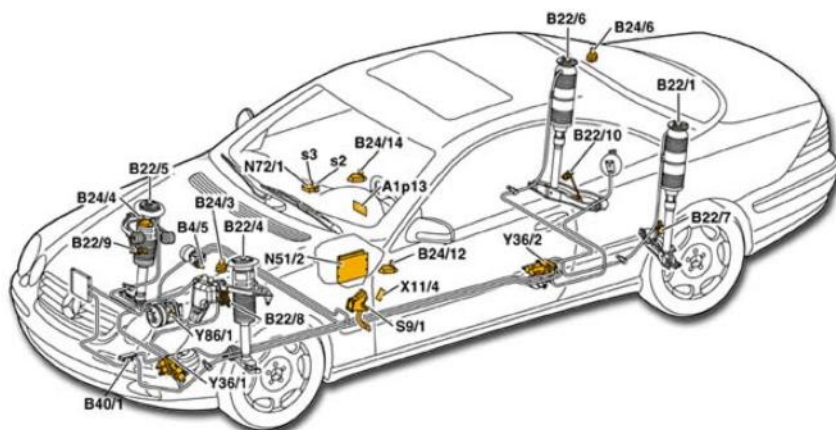

A1p13	Multifunction indicator	B24/6	Right rear body acceleration sensor
B4/5	ABC pressure sensor	B24/12	ABC lateral acceleration sensor
B22/1	Left rear suspension strut motion sensor	B24/14	ABC longitudinal acceleration sensor
B22/4	Left front suspension strut motion sensor	B40/1	ABC oil temperature sensor
B22/5	Right front suspension strut motion sensor	N51/2	ABC control module
B22/6	Right rear suspension strut motion sensor	N72/1s2	Level control system switch
B22/7	Left rear level sensor	N72/1s3	Comfort and sport switch
B22/8	Left front level sensor	S9/1	Stop lamp switch
B22/9	Right front level sensor	X11/4	Data link connector (DTC readout)
B22/10	Right rear level sensor	Y36/1	ABC front axle valve assembly
B24/3	Left front body acceleration sensor	Y36/2	ABC rear axle valve assembly
B24/4	Right front body acceleration sensor	Y86/1	Active Body Control (ABC) suction throttle valve

The control module monitors all the sensors in the system and decides how much fluid should be in each strut. It reevaluates 10 times per second.

All these sensors and valve solenoids are wired to the ABC control module. Failure of any of these sensors will disable the ABC system, causing an "ABC Drive Carefully" or "ABC Visit Workshop" message on the dash. The message will be in white or red depending on the severity. The error condition will also get logged for later viewing by diagnostic tools.

Driving the car while this message is on the dash can be very dangerous, especially at highway speed. Hence the "Drive Carefully" message. The system is in limp mode allowing you to get the car to the workshop. It is not to be ignored.

Should the ride height of any of the 4 corners of the car fall to an unacceptable level, the ABC system will display a "Too Low" warning. You should pull over immediately or risk damage from the tires coming into contact with the wheel wells, not to mention a possible accident that might occur from that happening. It is better to deal with the inconvenience of having the car towed rather than incur expensive repairs to the car.

Mercedes dealerships and other workshops that work frequently on Mercedes vehicles will have the STAR Diagnostic System, referred to as SDS or STAR. It is software that runs on a laptop along with various interface cables. It was developed by Mercedes for their vehicles. It connects to the various control units on the car (like the ABC system), and can retrieve error codes, examine the current values of sensors, execute diagnostic routines, calibrate sensors, view the error history logs, etc.

The major ABC components...their purpose, how they fail, and what to do.

Pump



The power steering and ABC pump are integrated into one unit, referred to as a Tandem Pump. Although the two pumps share the same pulley and shaft, they are separate components otherwise. It is possible for the ABC pump to fail but the power steering pump is fine (and vice versa). But if one fails, both have to be replaced since they are one unit.

The pump is lubricated by the fluid, so it is important it never run dry. If you are having fluid leaks be sure to keep a close eye on the fluid level in the reservoir. Should the fluid run dry the pump will be destroyed, and it will shed debris with sharp edges into the ABC system. This will generate problems with downstream components for years to come.

There seems to be some consensus that the average life of a pump is around 60-80K. Like any component, some will fail sooner and some may last much longer. Pumps cost around \$2,500 to replace.

Integrated into the pump is a suction restrictor(Y86/1) or throttle valve. It is wired to the control module and open and closes based on the voltage supplied to it. The opening and closing of this valve controls the rate of flow from the reservoir into the pump.

The pump may fail one of two ways.

1. It goes completely and cannot generate any pressure - somewhat rare.
2. The pump wears and cannot maintain steady pressure as it did before - the most likely scenario. It progressively gets worse, making error messages on the dash more frequent and more persistent.

The pump failing completely should be pretty obvious to diagnose. The ABC "visit workshop" or "drive carefully" message will appear shortly after the car is started, and the message will stay on. The car will not raise on command either. SDS error codes will indicate inadequate or no pressure.

It is important to remember that when the ABC warning message stays on the dash, the ABC system is disabled, effectively in "limp mode". The valves to the struts are locked closed, allowing you to drive to the workshop. The quality of the ride is often described as a "tuna boat" ride, depending on what height the struts were locked at. The switch to raise or lower the ride height will also be disabled.

If the pump is weak, you should also get ABC "Drive Carefully" and "Visit Workshop" messages, but they will be intermittent in nature. If the pressure drops too low at any point, the ABC system disables itself and displays the message on the dash. It stays disabled until the car is shut off and restarted. In many cases you can restart the car and the system will pressurize successfully, and the error message will clear. The car works normally again for a while. There will also be pressure related error codes logged as well.

Some owners report the ABC system operates fine when the car is cold, but the error messages start appearing after the car has warmed up. The reverse also seems to be reported. Temperature does seem to be a factor.

It is also suggested the suction valve may be the culprit, and not the pump itself. But unfortunately the valve is not sold separately, it comes with the pump. Check to make sure +5 volts or more is present at

the suction valve if the pump is not producing pressure in order to rule out wiring or control module issues.

Some owners report a grinding or growling sound the pump goes bad.

It should also be noted that low pressure codes do not necessarily mean the pump. Accumulators can fail leading to intermittent low pressures (when hitting bumps). The suction restrictor valve could be malfunctioning. The pressure check valve could be malfunctioning. The pressure sensor itself could be malfunctioning.

There is a SDS diagnostic test to measure the health of the accumulators (pressure reservoirs). Before replacing a pump, always run this test to rule out the accumulators being the cause of intermittent pressure problems.

The best way to know for sure if the pump is bad is to monitor the pressure while doing a rodeo. The rodeo will stress the system, and even a good pump will see about a 1/3 pressure drop at times. So if the car can get through the rodeo successfully, then the pump is probably fine. If there are still pressure related codes being generated after passing a rodeo, I would recommend investigating some of the other possibilities mentioned earlier.

<http://www.benzworld.org/forums/attachments/r230-sl-class/895217d1397771677-abc-pump-information-change-part-number-r-i-high-pressure-pump..pdf>

<http://www.benzworld.org/forums/attachments/r230-sl-class/888065d1397470652-abc-pump-information-change-part-number-initial-operation-new-tandem-pump-ar32.50>

Pulsation Dampener / Pressure Check Valve / Pressure Sensor Assembly

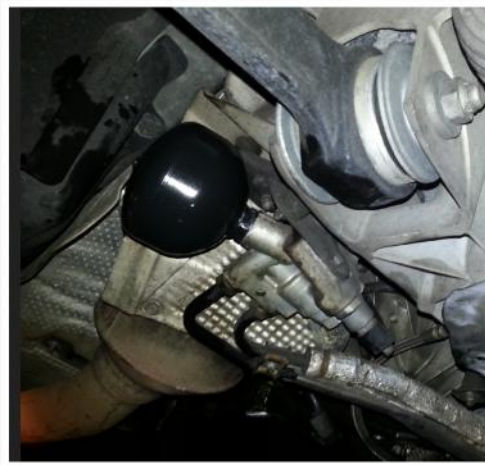

These three components are grouped together into the same assembly. They are the first set of components immediately after the pump.

There is a pulsation dampener (52a) attached to the assembly, part number 2203270215. It is a black sphere. It is similar in design to the other three accumulators in the system (nitrogen gas behind a rubber membrane), but much smaller. Since the fluid flow from the pump is "choppy" given the nature of its design, something is needed to smooth out these waves or vibrations in the fluid. This is the job of the dampener. Air behind the rubber membrane acts as a cushion and evens out the pressure, much like a gas shock absorber removes road vibration.

There is also a check valve (52b) integrated into the assembly. It is a passive device, not actively controlled by the control module. It will open when the pressure exceeds its designed limit (~190 bars),

allowing any excess pressure to be bled off. Its job is to regulate the system pressure.

Lastly, there is a pressure sensor (B4/5) attached to the assembly, and it is wired to the control module. A resistor inside the sensor alters the voltage passing through the sensor based on the amount of pressure applied to it. At zero pressure the voltage is around 0.6 volts. At full pressure it is at 5 volts. The control module monitors this voltage, and infers the system pressure from it.

There is an inverse relationship between the voltage from the pressure sensor and the voltage supplied to the pump suction valve. Then the voltage from the pressure sensor is low (the system needs more pressure), the voltage to the suction valve will be high (open up the valve and give me more), and vice versa.

So what can go wrong with these components?

1) The pulsation dampener could fail. The rubber membrane inside of it eventually breaks down, and the dampening ability is lost. You will hear a humming sound caused by the fluid vibration. The ABC system will function normally though, although the vibrations will stress the system if not addressed. I don't believe the control module will notice this, so no error codes or warning messages will appear. Just a loud annoying hum.

2) The check valve could be opening at too high a pressure. The control module should detect the overpressure and shut the ABC system down and display an ABC error message on the dash. It should also log the error.

3) The check valve opens at too low a pressure. I don't think it is a likely scenario but it is theoretically possible. In this scenario the control module will sense the need for more pressure and tell the suction valve on the pump to open up, and meanwhile the check valve will constantly route all that extra fluid back to the reservoir in an endless loop. If the pressure that this is occurring at is below the acceptable pressure to operate the ABC system, the control module will shutdown the ABC system and display a warning on the dash. If this endless loop is occurring at a pressure above the minimum but below the ideal, then the system will operate normally but the pump will be working extra hard. I'm guessing the control module would not notice this situation. It won't be able to tell the difference between a weak pump and a check valve letting off pressure too soon. But a constant 5V at the suction valve would indicate the pump is working full throttle all the time.

4) The pressure sensor is not working correctly. It could fail. There could be a loose connection between the sensor and the control module. It could be sluggish in responding to pressure changes. Or it could just be wrong about the pressure it is sensing. The control module should be able to detect a loose connection or a completely failed sensor and log an error code to that effect. That leaves the sensor reporting the wrong pressure. If the sensor is reporting higher than normal, then the control module will be seeing what it thinks are overpressure situations, and will shut down the ABC system and give a dash warning and log error codes. If the sensor is reporting lower pressure than actual, then either 1) in extreme cases the control module will think the system is below normal operating pressure and will shutdown the ABC system along with dash warnings and error codes. It could mimic a pump failure. 2) if a minor case, the normal drops in pressure will be more exaggerated from the control module's perspective, leading to intermittent "drive carefully" messages and occasional ABC system shutdowns.

5) Occasionally the o-ring that provides the seal for the pressure sensor will fail, causing a fluid leak. There is a repair kit available (part number A2203201158) for approximately \$80. Don't let the workshop convince you that you need to replace the entire assembly, a \$1,250 part. If the kit is not available, the shop should be able to improvise something with a similar sized sealing washer (like those used for oil drain plugs).

Accumulators



The accumulators (#4,#14,#53 on the hydraulic diagram above), are often referred to as a "air cell" or "nitrogen ball". They are black spheres that contain nitrogen gas (air) trapped behind a rubber membrane. Hydraulic fluid is allowed to travel in and out of the sphere based on the pressure differential between the rest of the system and the air on the other side of the membrane. The compressed air in the accumulator pushes back against the fluid and can either absorb pressure or supply pressure.

There are three accumulators placed strategically in the system. The two larger ones(4 and 14), part number 220 327 01 15, are attached to each of the two valve blocks and they provide the pressure necessary to add fluid to the struts when the valves open. The pump's job is just to keep these two accumulators topped off. These two are the most critical ones that will cause problems when they fail. The third accumulator(#53), part number 220 327 04 15, is often referred to as the "center" or "return" side accumulator. It is smaller than the other two and it's job is to smooth out the spikes in pressure that result when fluid is being let out of the struts. These accumulators are often overlooked since many techs do not understand their true function in the system. They are much more than just fluid repositories.

It is easy for workshop tech's to mistake the center accumulator for the rear axle accumulator. On the front side of the car the accumulator is co-located with the front axle valve block. But on some models the rear valve block has the return accumulator attached to the valve block and the main accumulator is some distance away. Be sure to refer to them by their part numbers when communicating with the tech.

The pulsation dampener(52a), part number 220 327 02 15, is arguably an accumulator as well. The design is the same. Its size and position in the system has it serving a different purpose though. It is to even out the vibrations in the fluid from the pump. When it fails you get this classic humming sound.

These accumulators wear out. Like any sort of wear part, how fast depends on a lot of factors. 60K-80K miles seems the norm from what I read. Your mileage may vary based on the age of the car, how clean the ABC fluid has been maintained, and so forth.

So, what can we take away from all this?

1) Accumulators play an integral role in the system. They act as "shock absorbers" in the sense that they even out spikes in the hydraulic system pressure. For that reason alone, making sure they are in good working order is important in that they will likely reduce stress (and eventual failures) on the rest of the system.

2) If the two larger accumulators(4 and 14, P/N 220 327 01 15) that provide pressure to fill the struts were to weaken or fail, then there will be momentary drops in system pressure. It will be most noticeable when the car hits a bump or drop in the road, which requires fluid to be added quickly to the struts to compensate. The control module is monitoring system pressure and when it sees the pressure drop, it puts the "Drive Carefully" warning on the dash. When the pump catches up moments later the message goes away.

My impression, from personal experience and from reading posts, is that the pressure drops (and resulting error codes being logged) frequently lead shops to replace the pump, when the accumulators were the real culprit.

So how do you tell if your accumulators are in good shape?

Getting intermittent "Drive Carefully" messages when hitting severe bumps or drops in the road indicate your accumulators are beginning to fail.

There is a SDS diagnostic test for them. It charges up the accumulators and then measures how long it takes to discharge. The workshop tech may not be aware of this test, or think to run it because he doesn't understand their function in the system. Always run this test to rule out accumulator problems before replacing a pump.

Observing the dipstick levels. If an accumulator has failed or is extremely worn, then they will be holding on to more fluid than they are supposed to. When the car is shut off and the system is depressurized, this fluid is pushed back to the reservoir. This is what causes the classic reservoir overflow symptom when the accumulators fail. So a difference in fluid levels from when the car is running, and shut off, will indicate the overall health of the accumulators in the system (assuming the measurements are taken with fluid at same temperature and ride height setting). A differential larger than the distance between the "engine running" and "engine off" marks on the dipstick could indicate wear on the accumulators. Having to maintain your fluid reservoir levels lower than normal to prevent overflows may also indicate failing accumulators.

Visual inspection. Most of these accumulators are easily accessible and removable. If you have the system down for repairs anyway, it may be a good time to spend a little extra time or money and have them pulled and inspected. If they are good, the rubber membrane should be near the entrance to the sphere. If they are bad or "blown", you can reach a considerable distance into it. Be careful and don't use anything pointed that could damage the rubber membrane. Of course pulling any part in the system does introduce risk of contaminants getting into the system. The risk/reward decision is up to you.

There is a test being advocated on the internet that involves pushing down on the bumpers and making sure there is minimal movement. But it is bogus. Even when working correctly the front will be stiff and the rear will have a lot of movement to it. The reason why the test is bogus is that when the car is shut off or the transmission is in park, the shut-off valves are engaged, preventing any fluid from entering or leaving the struts. The struts are isolated from the rest of the system, including the accumulators. I've seen more than one owner mistakenly convinced they have a bad rear accumulator because of this bad advice.

To recap, there are two common symptoms that point to your accumulators failing. The brief "ABC Drive Carefully" messages on the dash, and the reservoir overflowing a few minutes after the car is shut off. A SDS test might confirm the accumulators as well...be sure to mention it to the mechanic as he might not be aware of it. It might be a good idea to have this test done whenever the car is in for repairs.

So do your car and pocket book a favor and make sure these accumulators are all in good working order.

Here are some DIY resources:

<http://www.benzworld.org/forums/r230-sl-class/1742594-r230-abc-rear-valve-block-accumulator.html>

<http://www.benzworld.org/forums/r230-sl-class/1996449-abc-change-front-rear-pressure-reservoirs.html>

Valve Blocks

The valve blocks job control the amount of fluid in each of the 4 struts. There are two valve blocks, one for the front struts and one for the rear struts.

Front Valve Block	Rear Valve Block
-------------------	------------------



the accumulator attaches to the other side of the bracket



with the center or 'return side" accumulator attached

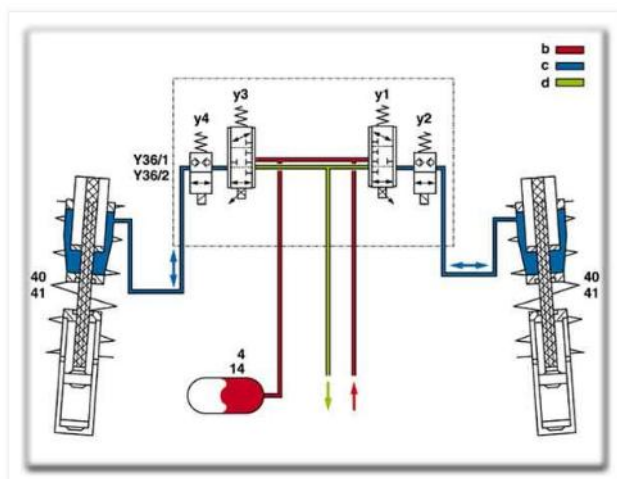

For each strut, there are two valves.

The main control valve (y1) is a 3-position valve. In the outer position it allows fluid to enter the strut, in its center position it closes off the strut, and in the inner position it allows fluid to leave the strut. When the ABC system is active, this valve is doing all the work.

The other valve (y2) is the shut-off valve that sits between the main control valve and the strut. Its purpose is to lock the struts at their current fluid levels when the ABC system is not in operation. When the car is not running or the transmission is not in gear, this valve is closed. When the car is put into drive or reverse, the valve will open and allow the fluid levels to be managed by the main control valve. If the control module senses a malfunction and disables itself, it will also close this shut-off valve for safety reasons.

So each valve block has 4 valves in it in total. These valves open and close based on voltage being supplied to them by the ABC control unit.

These valve blocks rarely fail outright. What happens is that contaminants in the hydraulic fluid builds on the seat of the valves, or the o-rings in the valve deteriorate. Either way, the valve no longer makes a good seal. As a result, fluid slowly escapes past the shut-off valve (y2) and the main control valve (y1) and returns back to the reservoir. This causes the strut to lower and the corner of the car to sag while parked.

It is possible (although rare) the car sagging is a fluid leak, such as the line between the valve and the strut, or a leak in the strut itself. If the leak is severe enough to cause noticeable sagging while parked, there should be obvious signs of the leak such as puddles on the garage floor.

When the car is running, the control module will compensate for any leaks in the valves. It is constantly monitoring levels and adjusting as necessary. The sagging would only occur when the car is parked and shut off.

If you are having issues with the corner of the car not being at the correct level when running, or exhibiting other odd activity, then you probably have a sensor issue (to be discussed later). If multiple corners can't stay at the correct height when running, you may have a pressure/pump problem. There is also a check

valve in the system that regulate system pressure, and that will be discussed later as well.

If the sagging is really severe, the ABC control module may notice it while the car is running and the transmission is in park. If so a C1531-004 "suspension strut moves although locking valve is closed" error code will get logged. It means the control module noticed the drop and added more fluid to compensate. The leak needs to be pretty bad to generate this error.

Unless the sagging problem is severe, it is not an urgent problem that you have to rush to the repair shop for. You can monitor the situation over time and decide when it has reached the point you want to fix it. There is the chance the debris holding the valve open will dislodge on its own. Going for a spirited drive might dislodge it. In the meantime be careful not to let the corner sink all the way down while parked, as the wheel well may come into contact with the tires. Be sure to park with the wheels oriented straight ahead to avoid wheel well damage, and to start the car periodically to pump up the strut.

You should also be sure to keep an eye on the reservoir fluid levels. If too much fluid leaves the struts, it may overflow the reservoir. Then when you start the car and the struts are pumped back up, the system may be extremely low on fluid, which may cause pressure problems and/or damage the pump. It would be wise to carry a spare quart of ABC fluid in trunk for this situation.

If and when you have to fix the valve blocks, you options are to:

1) Filter the fluid (requires two filters) and perform a rodeo (a test that exercises the system) . Cost would be around \$200-300. If the cause is debris rather than an o-ring, then it may dislodge some debris from the valves, but the results will be marginal and probably temporary. Sort of like trying to clean a fry pan by just running water over it. If the ABC fluid is older that 40K miles, many on the forum would suggest replacing the fluid as well (about \$250+labor).

2) Overhaul the valve assembly. This is not an approved MB procedure. Many members have reported success in pulling the valves and cleaning them. Replacing the o-rings is also a good idea, but it may take some research to find suitable replacements since there are no MB part numbers for them. There are also DIY write-ups and a youtube video as well. Your local Indy shop may be willing to do this for you, with no guarantees of course. Parts cost would be minimal and labor cost around \$1,000.

3) Replace the valve block assembly. This will run you around \$2,000. If saving money isn't a concern then this is the best option to fix the problem.

Anyway, valve blocks leaking is a very common problem and is also the easiest component to diagnose. If the car sags when parked, and there are no signs of fluid leakage, then you have a leaky valve block. There aren't any other explanations.

I've read numerous reports where repair shop told owners they need new pumps to fix this issue. If you are told this go to another repair shop since the tech clearly doesn't understand the design of the ABC system and is grasping at straws(at your expense).

Here are some DIY resources:

<https://www.youtube.com/watch?v=vqkzf2LRoPQ>

<http://www.benzworld.org/forums/r230-sl-class/1635269-abc-valve-cleaning-diy.html>

Reservoir

The purpose of the reservoir is to provide a place to store fluid when not in use. The green arrow points to the dipstick location. The dipstick has two marks. The lower one for when the engine is running. A higher one for when the system is shut off. When all is well and there are no leaks, you should never have to top off the fluid levels. Dropping fluid levels indicates a leak in the system somewhere.

The fact that the dipstick mark for when the car is running is lower than the one for when the car is off indicates it is normal for some fluid to flow from the ABC system back to the reservoir when the car is shut off and the system depressurizes. Remember that fluids do not compress. What happens is that the accumulators hold fluid when the system is under pressure, and the amount of fluid returned is proportional to the amount of fluid being held there during operation. It can take 5-10 minutes for the system to depressurize, so be patient before taking measurements or beginning repairs.



So, if the reservoir overflows, the possibilities are:

1. It is a common to mistake the dipstick marks as "minimum" and "maximum" levels, especially since the marks are labeled in German. So owners (and sometimes workshop techs) fill the fluid to the top mark by mistake while the car is running, or they top off the fluid too soon after shutting the engine off (remember it takes a few minutes for the system to fully depressurize and the fluid to return). The end result will be the fluid overflowing the reservoir. It won't hurt anything, but it will make a mess of the engine compartment.
2. An accumulator membrane has blown completely, releasing its nitrogen gas into the system. Then the system depressurizes and the gas expands, pushing fluid into the reservoir and overflowing it.
3. The accumulator membrane is still intact, but much of the gas opposing the fluid has permeated the membrane over time. As a result, it takes more volume of fluid in the chamber to reach the same pressure as before. When the car is shut down and the system depressurizes, the accumulator dumps its fluid and the volume exceeds what the reservoir was designed for.

So the take away is that the reservoir overflowing fluid out the dipstick cap is a pretty clear sign of one or more bad accumulators. If you also find you need to keep your fluid levels somewhat below normal to keep the reservoir from overflowing, it indicates your accumulators are worn out and will likely go soon.

Now if the level of fluid gets too low in the reservoir, the pump will start ingesting small quantities of air along with fluid, leading to a loss of pressure and ABC warnings on the dash. The pump is lubricated by the fluid, so this will put increased wear on the pump if not corrected. If you let the pump run dry, it will be destroyed in quick order.

So another takeaway is your first action on a ABC warning should be to verify you have adequate fluid levels to protect the pump. Pull over immediately (seconds count) and check to make sure the dash message is not the result of losing fluid. If the pump runs dry, it will be destroyed in a matter of minutes! Quick action can save you a \$2,500-3,000 repair bill.

Here are some DIY resources:

<http://www.benzworld.org/forums/r230-si-class/1899049-abc-fluid-filter-change-diy.html>

<http://www.benzworld.org/forums/attachments/r230-si-class/888001d1397460364-abc-pump-information-change-part-number-230-abc-bleed.pdf>

Hoses

There is a considerable amount of hoses and piping traversing the vehicle. Each connection point presents an opportunity for a leak to occur. Keep in mind the plastic panels under the car can mask many fluid leaks. A typical

hose leak repair will cost you \$500 - \$1000.

The exception is the high pressure expansion hose that runs from the pump underneath the engine just below the crankshaft pulley, where it then double backs and heads to the pressure dampener/sensor/check-valve assembly. To replace the hose requires disconnecting one of the engine mounts and jacking the engine up a couple of inches to get it out. Due to the extra labor and it being a specialty hose, it is a more costly repair...around \$1500.

Unfortunately it is also a common failure point. Some MB models had a recall on this part. Be sure to check if your car was part of the recall.

Some people like to speculate that a hose blowing will cause the car to drop suddenly onto its wheels and cause a crash. This is highly unlikely. The control module has to energize the shutoff valve for each strut to allow fluid to enter or leave the strut. If the control module senses anything wrong (like a pressure drop), or the control module itself would fail, then the voltage to the shutoff valves will be interrupted and the valves will close, locking the fluid in the struts. Conceivably the line between the valve and the strut could fail, or the strut itself could fail, but I suspect these parts are designed not to "blow" altogether, just develop leaks.

The Control Module

The control module is the brains of the system. It is constantly monitoring the inputs from the sensors, and adjusting how much fluid should be in each strut to meet the needs of the current situation.

The "sport" switch changes how aggressive the control module should be about countering the leaning effects.

The driver can also increase the ride height by either 1/2 inch or 1 inch. This is useful when more clearance is needed, like driveways and speed bumps.



Now if the control module senses inadequate pressure to operate, or if any of the sensors provide in-plausible data, the system will shut itself down for safety reasons. The offending sensor will be logged for later retrieval by the SDS system.

Loose connections can happen - sometimes corrosion builds on the connectors, so pulling the connectors and cleaning the contact points may help. In one case, an owner had an issue with a broken solder point. Bad sensors or loose connections will often result in an error code with "fault in component" as part of the description. Values of 255 from a sensor generally mean "no reading" or "bad input".

Maintenance

Mercedes says this system is maintenance free. But nearly everyone on the message boards agree that the ABC fluid should be replaced on a regular basis. How frequently is a subject of debate.

My personal opinion is that the fluid and filter should be replaced every 20,000 miles or 2 years, whichever comes first. Or as another owner suggested, have the fluid changed with every other oil change. It will cost around \$200-300 dollars to purchase the 10 pints of Pentosin CHF 11S fluid, and about \$50 for a new filter. There are DIY write-ups on the web on how to change out the fluid.

You should check the fluid levels periodically since it may be your first indication of a hydraulic leak. Just because there are not any drops of fluid on your garage floor means you don't have any leaks. The panels

on the underside of the car tend to collect leaked fluid and may mask leaks.

It is extremely important to keep contaminants out of the ABC fluid. Wipe the area around the dipstick clean, and use a lint free cloth to check the fluids.

I recommend taking the fluid level measurement both running and engine off (wait 10 minutes for system to fully depressurize). Take the car for a short drive to warm it up and purge any air that might be in the system. Make sure the ride height is at the normal setting (no lights on the switch). Note the two fluid levels and the distance between. If the difference between the two is more than the distance between the two level marks on the dipstick, then you may have one or more worn accumulators. If so keep a close eye on it. If you are having sagging or leaking issues, then you should keep a close eye on the fluid levels as well. Letting it get too low will damage the pump.

You should also drive the car regularly, at least once per week if not more. The reason being is all the hydraulic o-rings and seals do not do well with prolonged inactivity. Seals dry out faster. The o-rings in the valves become deformed from being held in the same position for extended periods of time. Gunk gets the opportunity to settle and harden. I understand that this is often the 2nd/3rd/4th car for many and only driven during summer months. Just understand there is some "cost" to leaving the car sit over the winter. The most likely impact being corner sagging issues will visit more frequently, in my personal opinion.

Purging air from the system

The system will purge itself of air in the system over time. If you were doing some work and want to get the air out immediately, you can do so by using the ride height button. Cycling through the levels about 15 times is sufficient to get most of the air out of the system. The rest will work its way out over time. A rodeo procedure can help speed the process along, but it is NOT necessary.

Also, some shops or techs are under the mistaken impression that rodeos and/or flushes are necessary after replacing components in the ABC system. It is not the case. Cycling through the ride height levels and adding back any lost ABC fluid is all that is necessary.

Some message board owners have made a good point that doing a rodeo is rather stressful on the system (it is designed to be). Sometimes a hose will burst or a strut will fail during the test. It can be argued that the rodeo helped you find a component that was about to fail anyway, but who really knows for sure. My point is use this procedure sparingly.

Costs of Ownership of the ABC System

This is a costly system to repair. Most of the components in the system have a useful life of around 70,000 miles or so. Purchasing a car with 70,000 miles and owning it to 120,000 miles will be a costly proposition. You can realistically expect to have to replace the following during this period of the car's life:

Item	Parts	Labor	Cost
Pump	1500	1000	\$2,500
Front Valve Block	1250	1000	\$2,250
Rear Valve Block	1250	1000	\$2,250
Front Block Accumulator	150	1000	\$1,150
Rear Block Accumulator	150	350	\$500
Return Accumulator	150	1000	\$1,150
Pulsation Dampener + Check Valve + Pressure Sensor Block	1,000	500	\$1,500
Struts X 4 (in all likelihood at least 2 will either leak or the travel sensor inside will fail)	1,250	750	\$2,000ea
Total Costs (dealer pricing, all done separately)			\$15,300

I must be exaggerating, right? I wish I were. If you spend some time on the on-line forums reading

discussion threads on ABC problems, you will see that I am not.

But there is some good news. With the exception of the pump, the other components of the ABC system (the valve blocks, accumulators, and struts) are in easy to access locations, and replacing them requires only basic mechanical skills. There are do it yourself write-ups and videos on the web, and support forums where other owners can provide advice.

So if you are the adventurous type that doesn't mind getting his hands dirty, then you have lots of options to cut down your repair costs. And you really don't have much to lose other than a tow bill and eating a little humble pie. If you don't succeed, just put things back the way they were and get the car to a good Indy shop and have them do the repair with your supplied part.

Item	How to Save Money	Savings
ABC Fluid	It is important to keep this fluid clean and fresh. As time goes by, the hoses, accumulator membranes, struts, and other rubber components shed microscopic debris into the fluid. This debris shortens the life of the components in the system, especially the valve blocks. This gunk tends to deposit on the valve seats preventing a good seal. So flush the fluid every 2-3 years. There is a DIY writeup on the net. Also, when accumulators fail, they shed significant size chunks of rubber membrane into the system. It is important to be proactive about replacing these before they fail, and if one does fail be sure to flush the fluid to get out as much debris as you can. Same goes for a pump failure.	Hard to quantify, but a significant savings
Pump	You can replace the pump as a DIY project, and write-ups are online. It is a little more challenging than the other components. Unless you have some experience replacing power steering, water, and other pumps on engines, it is probably best left to the workshop to do.	\$0
Front Valve Block	There are DIY guides to pull and clean these blocks	\$2,250
Rear Valve Block	There are DIY guides to pull and clean these blocks	\$2,250
Front Accumulator	You can proactively replace this accumulator any time the valve block is cleaned or replaced, saving the labor cost.	\$1,000
Rear Accumulator	This is a fairly simple DIY project	\$1,000
Return Accumulator	You can proactively replace this accumulator any time the rear valve block is cleaned or replaced, saving the labor costs.	\$350
Pulsation Dampener Check Valve Pressure Sensor	You can't replace these components separately, only the complete assembly. Replacing it is a fairly simple DIY project	\$500
Struts	There is an alternate supplier (Arnott) that sells replacement struts for about \$500 each. If you are a capable DIY person you can replace them yourself, or spend about \$300 for a competent repair shop to install them	\$1,250 ea assuming two will fail
	SAVINGS	\$10,000 +

Conversion to Standard Coil-Over Struts.

Another option is to replace the ABC system altogether with an aftermarket set of coil struts. Strut Masters sells a conversion kit. It consists of 4 standard struts and an adapter that you connect to the car to fake out

the system to thinking the ABC system is OK.

Cost will be around \$3,000-4,000 to have installed. Assuming you wait until an expensive ABC repair bill comes up, then the net cost becomes considerably less. You can also sell your used ABC components on ebay to other owners having failures, and recoup much of this cost.

Of course installing this kit eliminates the advantages of the ABC system. The ride will be a little harsher and the handling not as tight. You also will not have any anti-sway bars, so if you are an aggressive driver on corners, the car will have a greater tendency for over-steer(the rear end swinging out). Odds are you would never notice the difference unless you drive as if you are at the track.

Having the ABC system replaced is an option to consider if future repair cost is a concern.

Finding a repair shop.

As you can see, this is a highly complex system. And you will find that it is very hit and miss on finding a shop (including MB dealerships) that are knowledgeable about the ABC system. It is very common for the workshops to misdiagnose the problem. For example, I had a problem with intermittent "Drive Carefully" messages on my dash. The MB dealership first thought it was leaking hoses (\$1,000), then they tried the pressure sensor(\$1,500), and finally replace two accumulators, which was the problem (\$1,000). This experience is typical, from talking to other owners on the message boards.

The shop having a SDS system is a requirement for troubleshooting and working on the ABC system. If the shop you go to for ABC work doesn't have one and tries to convince you it isn't necessary, go elsewhere! The ABC system will log any problems it has in the form of error codes, and these codes are necessary to correctly diagnose most problems with the ABC system. These codes cannot be read using standard OBD scanners. But keep in mind these codes only provide clues, not answers. It is all too common for techs using this system to swap out the wrong part because of errors they see in the logs.

I wish you luck on getting your ABC problem resolved, and keeping that dreaded "ABC Drive Carefully" message from appearing.

Darren

Posted by [Darren B](#) at 1:02 PM

 Recommend this on Google

Labels: [ABC](#), [Benz](#), [CL500](#), [CL55](#), [CL600](#), [Drive Carefully](#), [Mercedes](#), [R230](#), [SL320](#), [SL500](#), [SL55](#), [SL600](#), [SL63](#), [SL65](#), [Visit Workshop](#), [W215](#)

14 comments:



[tomtomterrific](#) October 18, 2014 at 5:01 AM

Darren,

Terrific blog post! I've also been scouring the forums and have gotten partial, sometimes sketchy, and even (as you mentioned) bogus advice. I tried the "bounce" test with the car in drive and it's tight. However I still believe I need new accumulator(s). Does the SDS diagnose individual accumulators? My local garage(s) don't have the right diagnostic equipment so I may have to go to the MB dealer, at least for the diagnostic. Thanks, Tom

[Reply](#)

[Replies](#)



[Darren B](#) October 18, 2014 at 10:06 AM

Hi Tom, regarding the SDS test for the accumulators, I was told this by Rod_84 on the benzworld.org forum. He has an SDS system and has run the accumulator test. He can better describe what the output is. Let me know what you learn and I'll add it to the blog.

If you are having ABC issues, have you posted your symptoms to any of the message boards? There are some pretty knowledgeable members on them that

can steer you in the right direction. Many of them own their own SDS setup. I've had good results using the benzworld.org R230 forum.



Darren B October 18, 2014 at 4:34 PM

Looking at the hydraulic diagram, it is possible for fluid from the rear accumulator to flow to the front valve block, and vice versa. So the front and rear accumulators can help each other out to some degree. I would be surprised if the SDS system can test them individually unless there is some sort of one-way flow restrictor somewhere that is not documented or something can be done like disconnecting a hose or something to isolate the two. SDS should be able to test their overall capacity by charging them up and seeing how long it takes for them to expel all their fluid. If you want to try replacing the accumulators...the rear one is considerably easier to pull and replace, so it best to start there. If replacing that one doesn't solve the problem then replace the front one.

[Reply](#)



Classyma Thomas October 23, 2014 at 2:22 PM

Hello what do you mean by tuna boat ride? I have a 02 cl500 that I just replaced front valve on and now I have to replace rear valve because im getting a code 1531-004 rear left strut moves even though locking valve is closed no visible leaks on ground by tire..it does while in motion the rear feels squirmy like car is lean more towards back when going over dips or bumps..

[Reply](#)

[Replies](#)



Darren B October 23, 2014 at 3:53 PM

What the benz forums call a "tuna boat" is when the ABC shuts down, and the suspension is extremely loose (you will know it when you experience it). You will also have a "Drive Carefully" message on the dash while this is going on. Sort of like being in a small boat. I don't think that is what is happening with your car from your description. The valve block is responsible for controlling the amount of fluid in the strut, and it needs to be overhauled or replaced since the ABC controller module is noticing fluid escaping from one of your struts (it returns back to the reservoir, not on to the ground). I would also check the color of your ABC fluid, and if it is dark or black have it flushed (despite what the dealer tells you). Dirty fluid is a key contributor to these valve blocks leaking, as the gunk builds up in the valves.

I also recommend signing up to a mercedes forum and posting your symptoms in detail, and get the benefit of multiple opinions.

[Reply](#)



mohamed ally December 9, 2014 at 3:43 AM

Hi darren,great post,thanks for the information,I need your help!! My left engine mount collapsed a few weeks ago,I only found thay out this week and it is being replaced,can this cause the car to sort of be unstable? The suspension is feeling very loose and the car is not stable,the white abc light is coming on if I have to accelerate,could you advice me as to what my problem could be? I would really appreciate it

[Reply](#)

[Replies](#)



Darren B January 3, 2015 at 5:12 PM

On some models, the ABC line from the pump to the pulsation dampener runs underneath the engine, and you actually have to jack up the engine to replace the line. From that I would infer it could get damaged from the engine mount collapsing. If the line was pinched it pinched restricting ABC fluid flow.

I see it has been almost a month since your post. Have you had the car looked at? Did you solve the problem? I'd be interested in hearing the solution so I can update the blog for the benefit of future readers.

[Reply](#)



Gary Quadra December 17, 2014 at 1:41 PM

Fantastic document! Thanks!

[Reply](#)



Jon Woolley December 22, 2014 at 3:17 PM

Hi I have recently fitted a pulsation damper on my car due to a humming noise as you described, but unfortunately it has not cured the noise. I was wondering if the other accumulators in the system could have this effect by making the system hum. I have lifted car onto ramp and the humming noise is coming from the ABC pipes under the car. Thanks Jonathan

[Reply](#)

[Replies](#)



Darren B January 3, 2015 at 5:08 PM

I've read some posts suggesting that the line that runs from the pump to the assembly containing the pulsation dampener also has dampening capabilities. Presumably one of the rubber sections has some expand/contract capability to reduce vibration.

I don't know if that is the cause or not, but I think it is worth investigating. I assume the line is bolted down securely?

If you find the issue, let me know so I update the blog to help others out with what you have learned. There are likely some gaps in my understanding of the system.

[Reply](#)



Toby Brown December 23, 2014 at 1:28 PM

Thanks for posting up this comprehensive description of the ABC system issues. Just took my 05 SL500 in - handed a print out of this to my mechanic. He said he wished he had this 6 months ago when working on a CL500.

Much appreciative of the work you did on this.

Best,
Toby

[Reply](#)



MacGyver January 6, 2015 at 11:13 AM

2002 CL500 - 'Airmatic Visit Workshop' in white display.
No ABC warning lights on, car is equipped with ABC, not airmatic.
Car can display both ABC and Airmatic in both white and red.
Lift button does not work. Limp mode?
Power steering feels a little tight.
No leaks or peculiar sounds, reservoirs correct level.
Anyone ever encounter these symptoms?
Valve block locked up at power steering relay/pulsation damper?
There is a pressure sensor at this block and it will throw a red ABC warning light if compromised.
What else to look for besides star diagnostics at the workshop?
Thanks

[Reply](#)

[Replies](#)



Darren B January 9, 2015 at 11:47 AM

The ABC system is clearly disabled. Only SDS will be able to show the error code explaining why. If you take the car to a shop to get an estimate for repairs, the

first thing they will do is hook up SDS to determine what is failing. You can then go from there. Pump is probably the most likely culprit, but it could be something as simple as a bad sensor or loose connection.

[Reply](#)



[funymuny](#) January 11, 2015 at 7:23 AM

Great write-up. Thank you for sharing all that info.

[Reply](#)

Enter your comment...

Comment as:

Publish

Preview

[Home](#)

Subscribe to: [Post Comments \(Atom\)](#)

Simple template. Powered by [Blogger](#).