

⚠ Pay attention to paint damage.

1 Clean holes for center air inlet grille mounting clips.

i Remove paint residues present with dia. 7.2 mm bit or awl.

2 Insert mounting clips (2) for center air inlet grate into cleaned holes (6 each).

i The openings of the mounting clips (2) should point in the direction of travel.

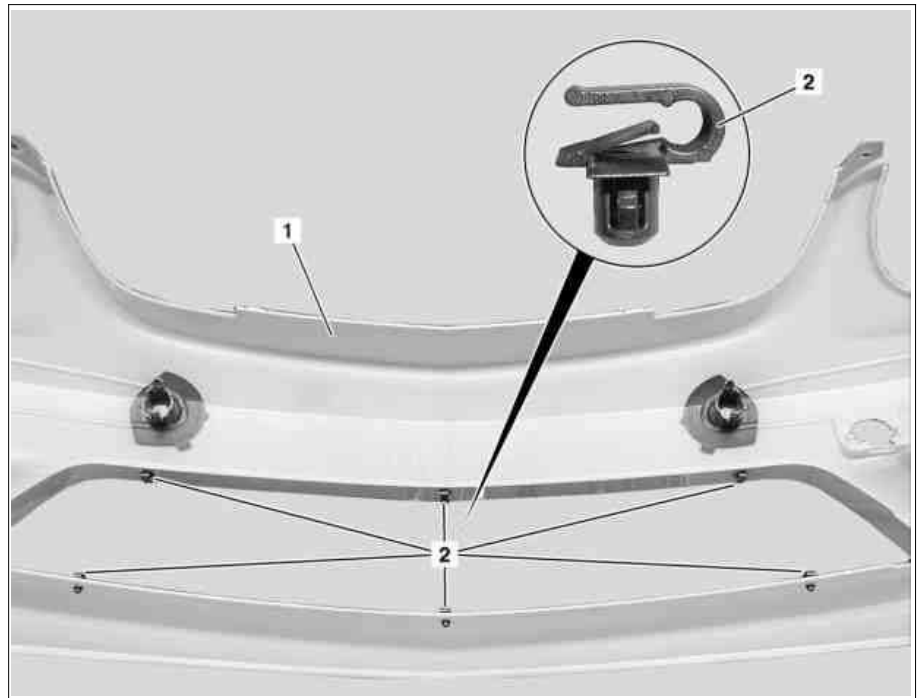

P88.20-2907-06

3 Install HCS cover (22), removed from standard bumper, with HCS spring (23) into front bumper cover (1).

i For this purpose, pull bearing bracket on HCS cover (22) apart and insert into bearing bore. Then close HCS cover (22) and insert HCS spring (23).

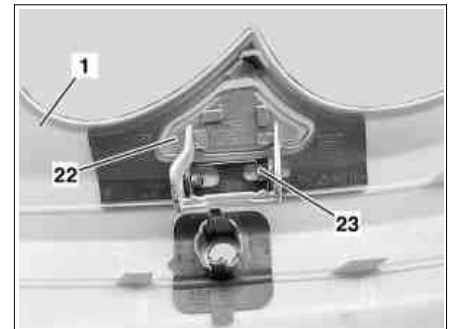

P88.20-2908-01

4 Install left cable passage (35) in front bumper cover (1).

5 Install spacer sleeves (36) on left and right in front bumper cover (1).

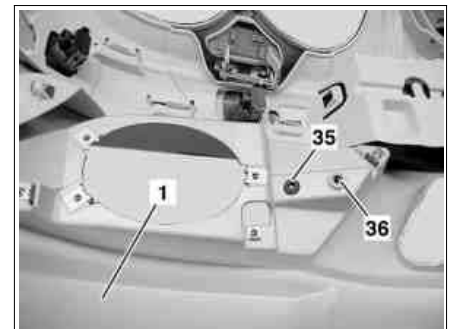

P88.20-2910-01

Only with Parktronic system (PTS) code 220

6 Insert front bumper PTS sensor units (A42) into brackets.

i Before inserting front bumper PTS sensor unit (A42) check decoupling rings; replace if damaged.

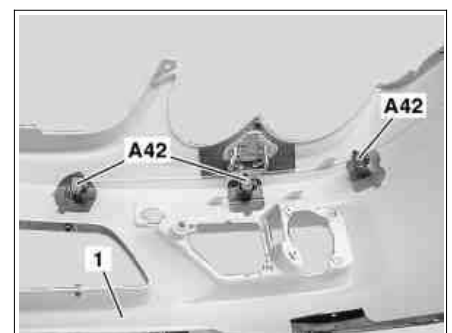

P88.20-2911-01

- 7 Install left reinforcement and right reinforcement on front bumper cover (1) and fasten with clips (12) (8 each).

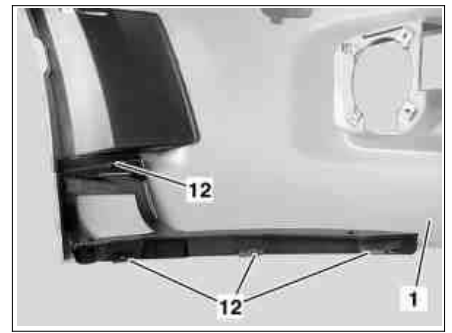

P88.20-2912-01

- 8 Insert plastic plates (51) into center impact absorber (30) and fasten with adhesive tape.

i Plastic plates (51) are different for left and right

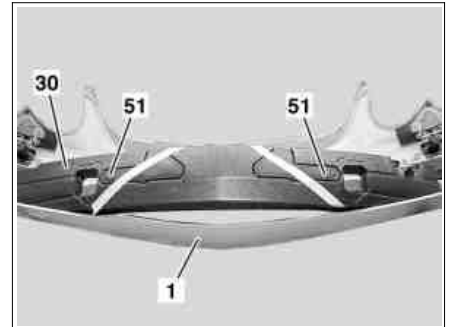

P88.20-2921-01

- 9 Insert center impact absorber (30), removed from standard bumper, into front bumper cover (1).

i On vehicles with Parktronic system (PTS), code 220, ensure that PTS wiring harness is routed correctly. The routing is defined in the impact absorbers.

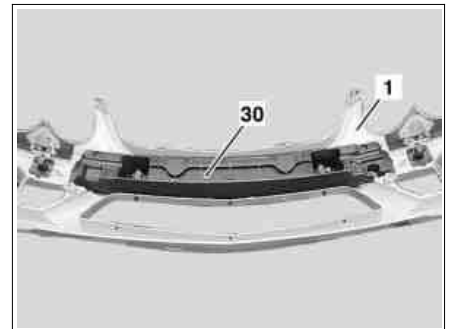

P88.20-2909-01

- 10 Insert left and right basic carriers (17) into front bumper cover (1).

i Ensure that the left and right basic carriers (17) are installed properly on the retaining lugs (8).

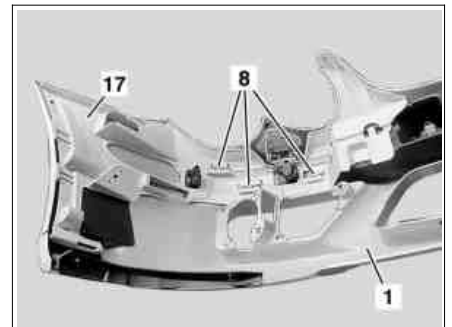

P88.20-2913-01

- 11 Fasten left and right basic carriers (17) at top of front bumper cover (1) with 6 expansion rivets (19) (see left bottom picture).
- 12 Fasten left and right basic carriers (17) in center on front bumper cover (1) with 2 expansion rivets (19) (see top right picture).
- 13 Insert spacers sleeves (36) at top left and right in left and right basic carriers (17) and front bumper cover (1) (see top left picture).

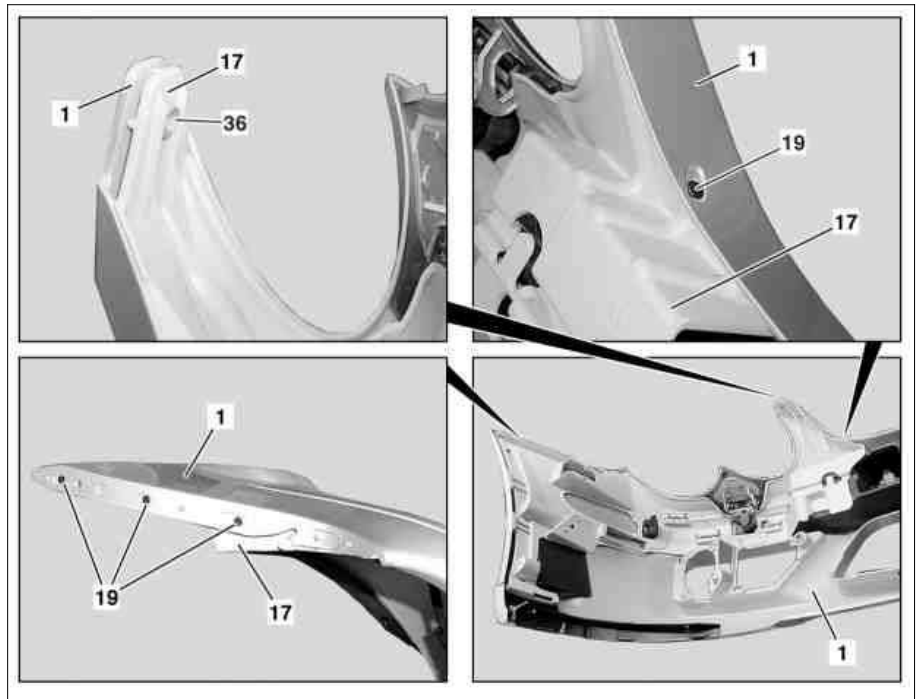

P88.20-2914-06

- 14 Install left and right impact absorber (29) removed from standard bumper into left and right basic carriers.

i On vehicles with Parktronic system (PTS), code 220, ensure that PTS wiring harness is routed correctly. The routing is defined in the impact absorbers.

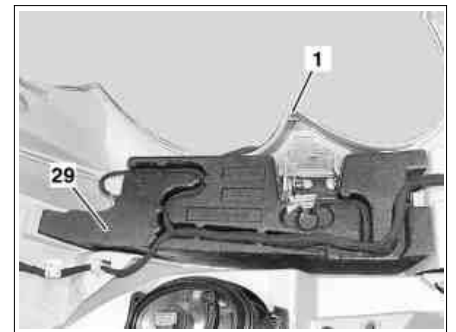

P88.20-2915-01

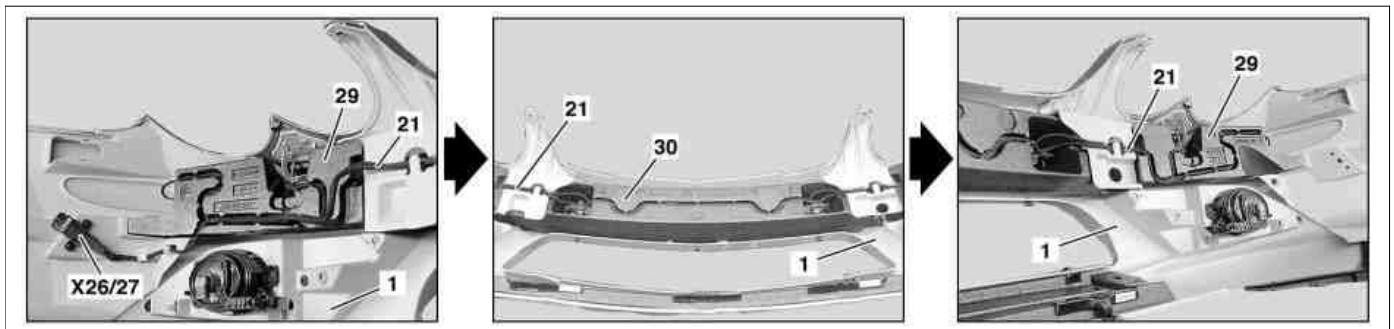

P88.20-2916-07

Only with Parktronic system (PTS) code 220

- 15 Connect front bumper PTS sensor units, to PTS wiring harness (21), removed from the standard bumper, insert into left and right impact absorbers (29) and center impact absorber (30) and fasten in present brackets.

Only with Parktronic system (PTS) code 220

- 16 Fasten PTS, front bumper connector (X26/27) to left and right basic carriers with two expansion rivets.

- 17 Insert center bottom reinforcement (31) into front bumper cover (1) and fasten with hot melt adhesive.

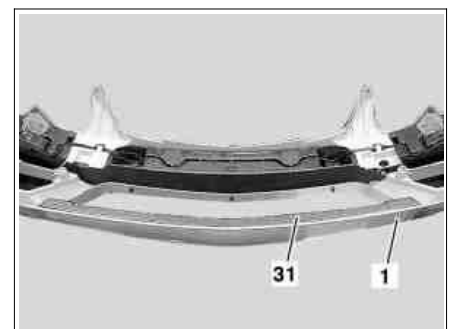

P88.20-2917-01

18 Install spring nuts (6) for fastening air inlet grate on left and right (6 each).

19 Install spring nuts (13) for fastening right and left front fog lamps (6 each).

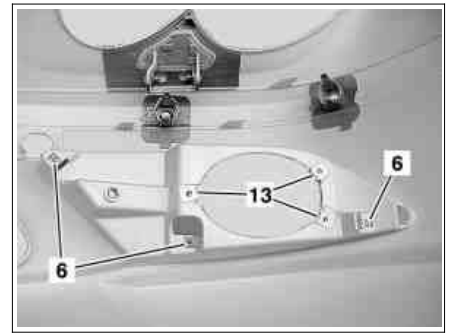

P88.20-2918-01

20 Insert left front fog lamp (E5/1) and right front fog lamp (E5/2) into front bumper cover (1) and install with four 4.8×19 combination bolts (15) each.

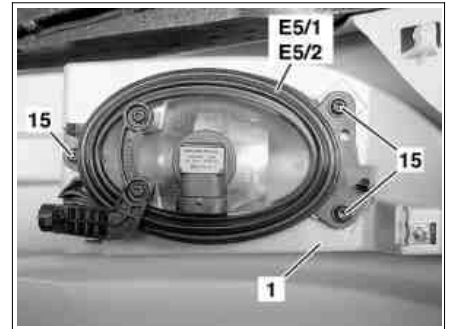

P88.20-2919-01

21 Insert towing eye cover (24), removed from standard bumper, into front bumper cover (1) and hook in retainer.

i Hook in retainer on tow eye cover (24) before inserting.



P88.20-2920-01

22 Insert center air inlet grille (32) and clip in temperature sensor.

i Precisely insert center air inlet grille (32) into mounting clips (2) to ensure proper arresting.

i The step is illustrated on model 209.

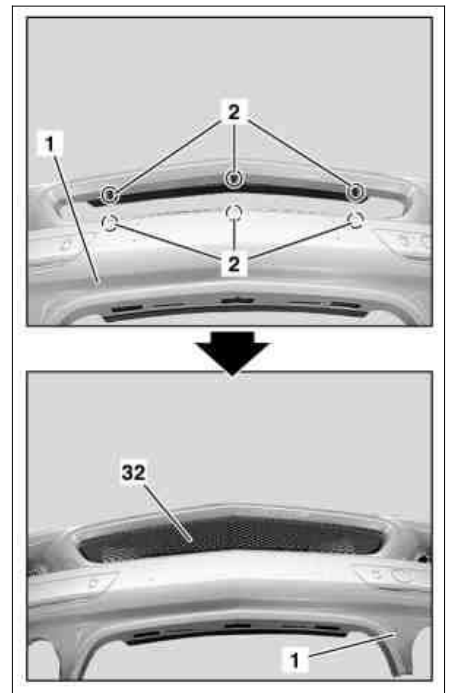

P88.20-2922-03

23 Install license plate frame (25) at outside of front bumper paneling (1) and prepare for assembly.

i Use license plate frame (25) as template for marking holes. The distance (a) between the license plate frame (25) and the left and right bumper strips should be equal. Align license plate frame (25) along contour of front bumper paneling (1) (see arrows).

i The step is illustrated on model 209.

24 Drill four holes for assembling license plate frame (25) and install license plate frame (25) on front bumper paneling (1) with four bolts (PT5×16)

i Tighten bolts only with screwdriver.

i The step is illustrated on model 209.

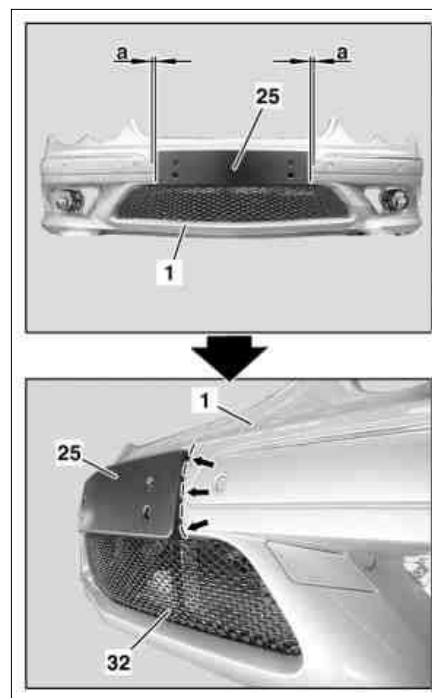

P88.20-2923-03

25 Insert left air inlet grille (27) and right air inlet grille (28) and fasten with 3 round head hex. bolts (St3.5×22) each.

i The step is illustrated on model 209.

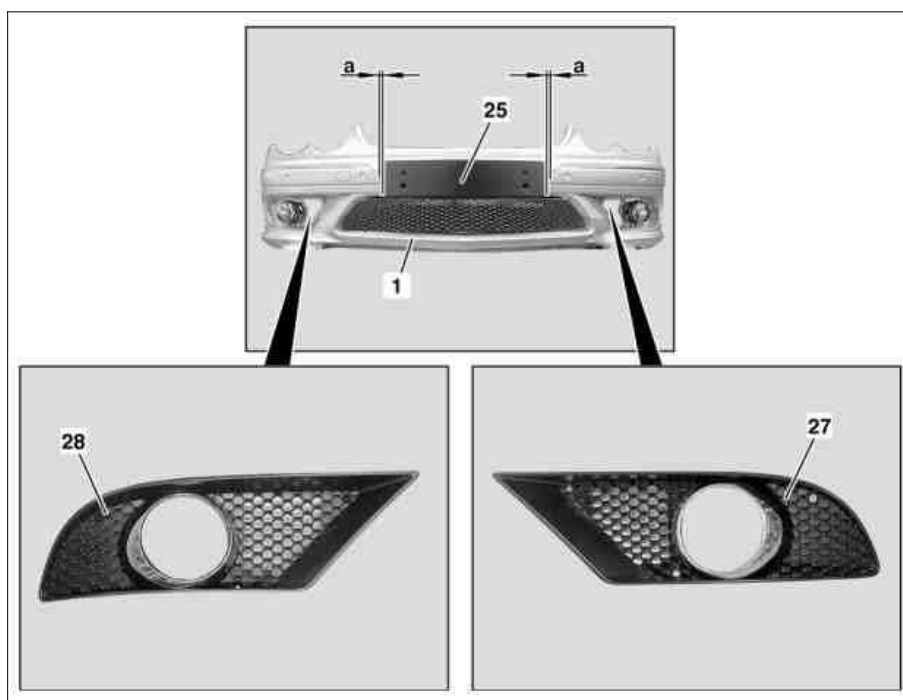

P88.20-2924-06