

i Check components removed from standard bumper before assembly and replace if damaged.

ⓘ Pay attention to paint damage.

- 1 Insert towing eye cover (24) into front bumper paneling (1) and arrest.
- 2 Hook check strap on towing eye cover (25) into front bumper paneling (1) and towing eye cover (24).

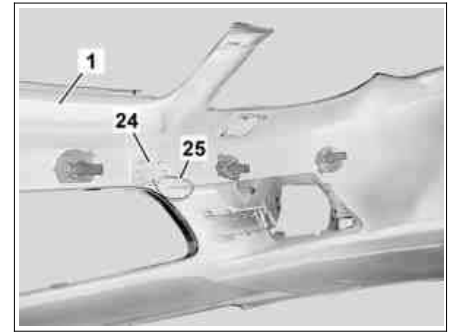

P88.20-3127-01

i Tie check strap on the towing eye cover (25) to attachment point in front bumper paneling (1).

- 3 Insert center front impact absorber (30), center air inlet grate (32) and center bottom reinforcement (31) into front bumper paneling (1).

i Before inserting center front impact absorber (30), insert plastic plates for mounting the license plate frame into center front impact absorber (30) and fix in place with adhesive tape.

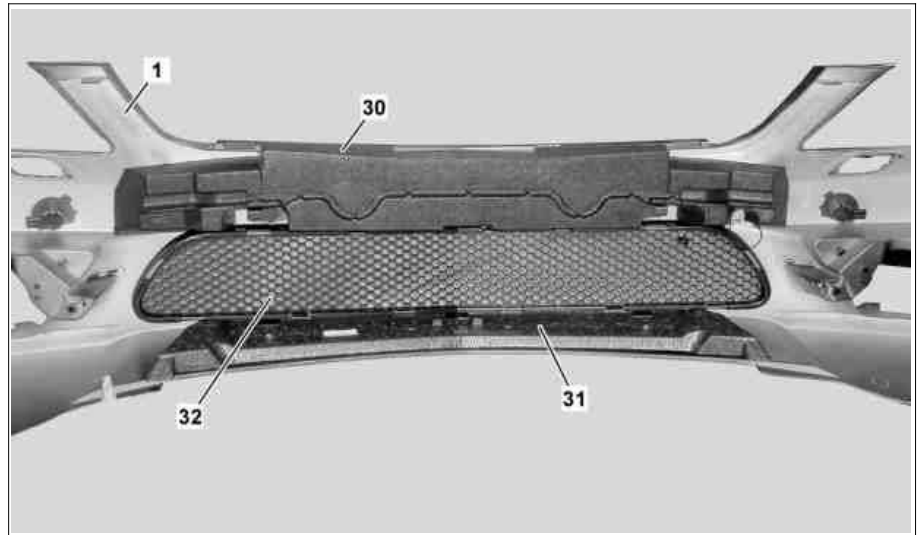

P88.20-3128-05

- 4 Install right and left center grate cover (33) on retaining lugs on front bumper paneling (1) and fasten with three clips (12) each.

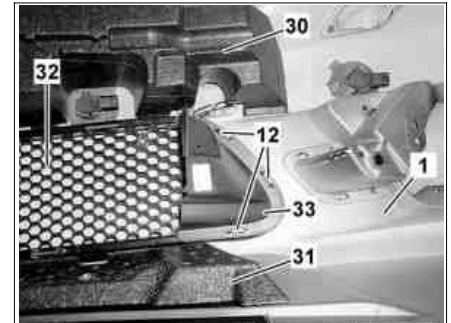

P88.20-3129-01

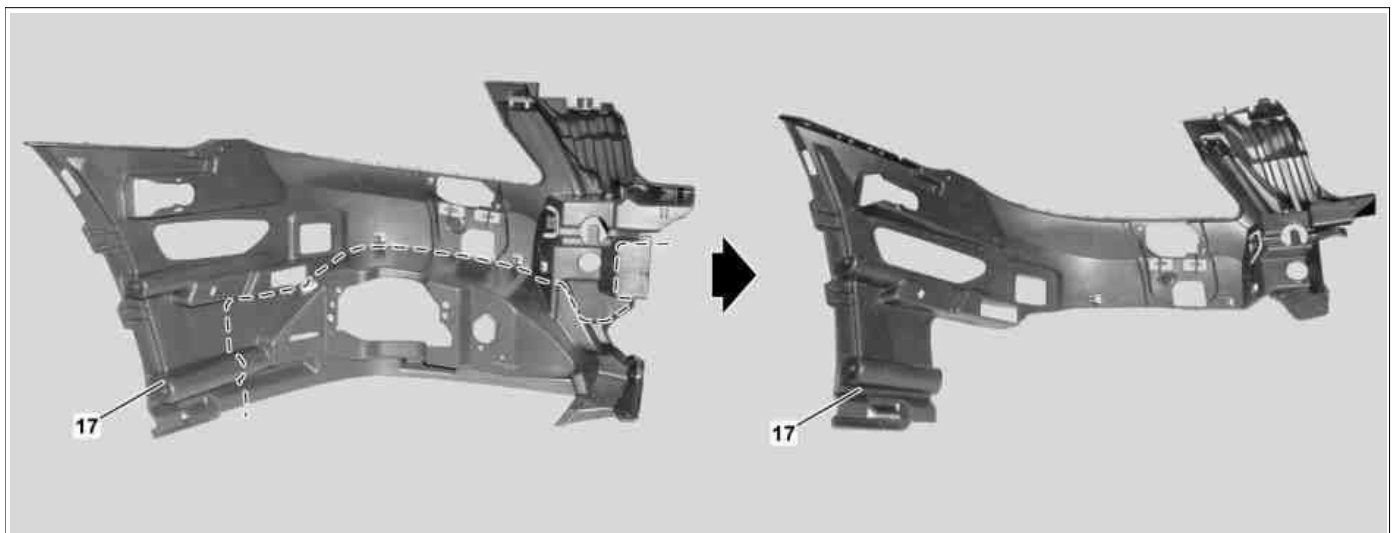

P88.20-3130-08

- 5 Prepare right and left front basic carrier (17) from standard bumper for installation.

i Machining is shown on the left basic carrier and is the same on the right and left..

i Saw out basic carrier along cutting line (shown on component, see broken line). The machined basic carrier is shown on the right side of the picture.

- 6 Insert left and right front basic carrier (17) into front bumper paneling (1).

i Ensure that the left and right front basic carrier (17) is inserted properly behind the brackets (see circle) and arrests in the lower catch lugs (see arrow).

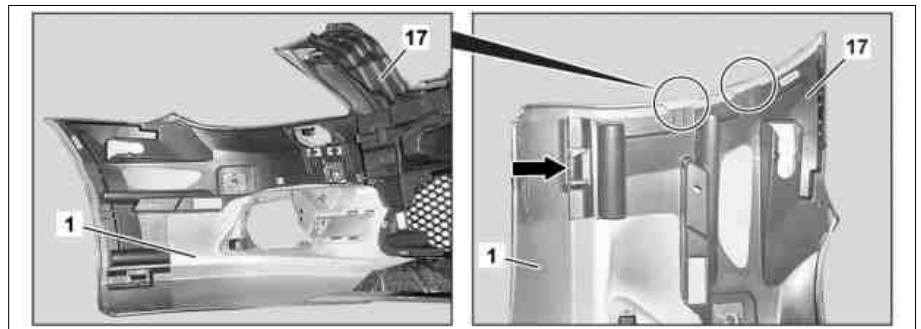

P88.20-3131-04

- 7 Arrest left and right front basic carrier (17) into upper retaining lugs on front bumper paneling (1) (see arrow) and insert spacer sleeves (36) at top left and right.

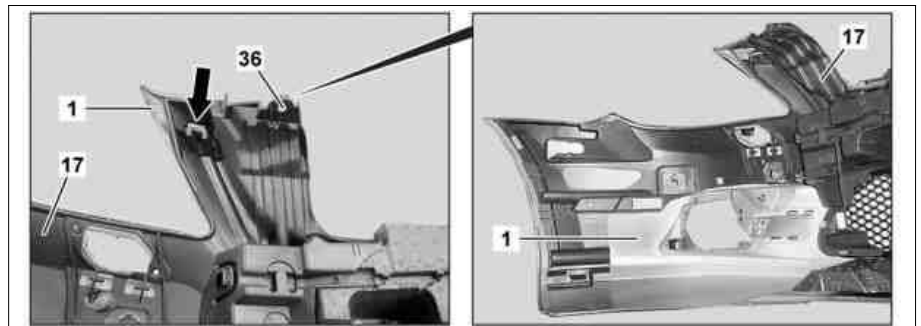

P88.20-3132-04

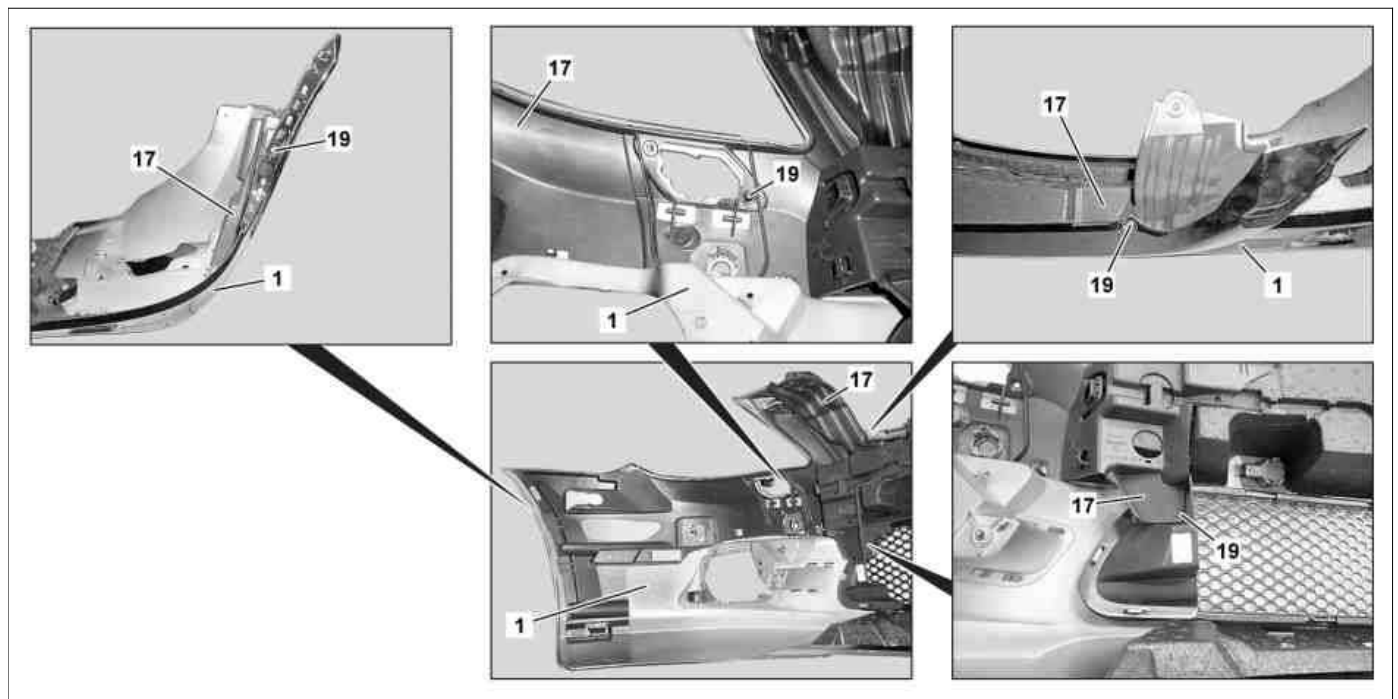

P88.20-3133-09

- 8 Fasten left and right front basic carrier (17) on top to front bumper paneling (1) with 2 expansion rivets (19) (see picture at top left).

- 10 Fasten left and right front basic carrier (17) on recess for radiator grille to front bumper paneling (1) with 2 expansion rivets (19) (see picture at top right).

- 9 Fasten left and right front basic carrier (17) on opening of headlamp cleaning system nozzles to front bumper paneling (1) with 2 expansion rivets (19) (see picture at top center).

- 11 Fasten left and right front basic carrier (17) on left and right center grate cover (33) to front bumper paneling (1) with 2 expansion rivets (19) (see picture at bottom right).

- 12 Insert spacer sleeves (36) on left and right into attachment points on front bumper paneling (1).



P88.20-3152-01

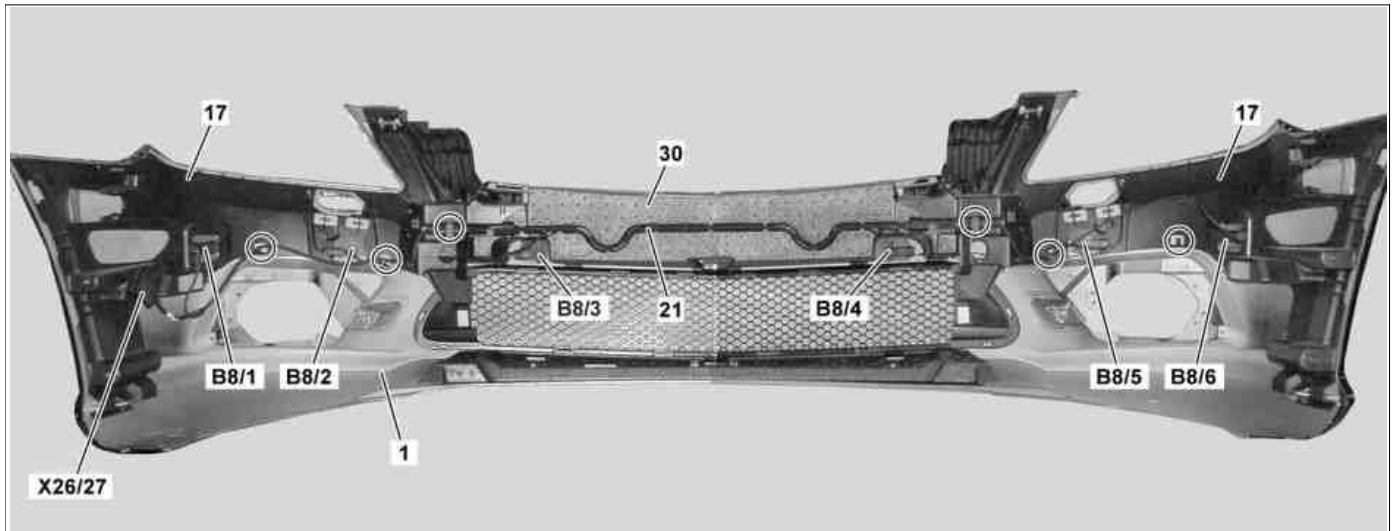

P88.20-3134-08

Vehicles with Parktronic system (PTS) code 220

- 13 Clip outer left front ultrasonic sensor (B8/1), center left front ultrasonic sensor (B8/2), inner left front ultrasonic sensor (B8/3), inner right front ultrasonic sensor (B8/4), center right front ultrasonic sensor (B8/5) and outer right front ultrasonic sensor (B8/6) into brackets on front bumper paneling (1).

i Previously check whether a decoupling ring (transparent silicon ring) is installed on all PTS ultrasonic sensors.

- 16 Install sheet metal nuts (6) for mounting right and left air inlet grate (8 each).
 17 Install sheet metal nuts (13) for fastening right and left front fog lamps (6 each).

- 18 Install HCS cover (22) with HCS spring (23) into front bumper paneling (1).

i For this purpose, pull bearing bracket on HCS cover (22) apart and insert into bearing bores. Then close HCS cover (22) and insert HCS spring (23).

Vehicles with Parktronic system (PTS) code 220

- 14 Connect PTS wiring harness (21) to PTS ultrasonic sensors as shown in picture, route to front bumper paneling (1) and fix in place to specified attachment points (circles).
 15 Insert front bumper PTS connector (X26/27) into left basic carrier and arrest by turning.

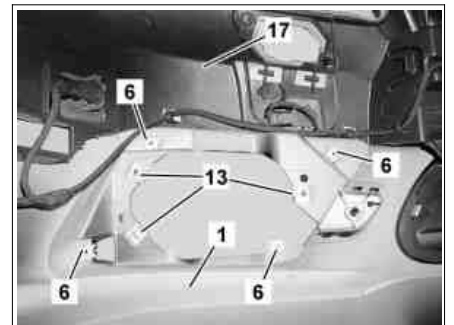

P88.20-3135-01

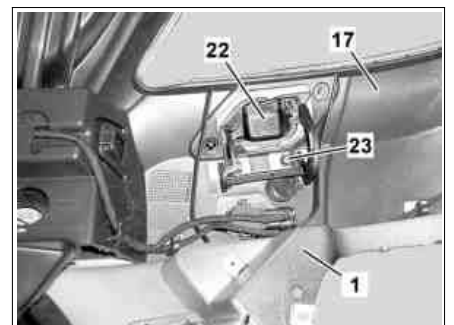

P88.20-3136-01

19 Insert left and right impact absorber (29) into left and right basic carrier (17) (see arrow) and arrest in center.

i On vehicles with Parktronic system (PTS), code 220, ensure that PTS wiring harness is routed correctly.

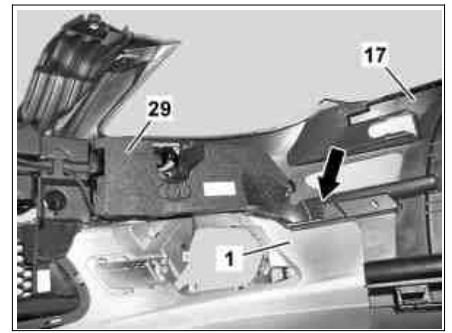

P88.20-3137-01

20 Insert left front fog lamp (E5/1) and right front fog lamp (E5/2) into front bumper paneling (1) and install with three 4.2 x 13 round Allen head bolts (15) each.

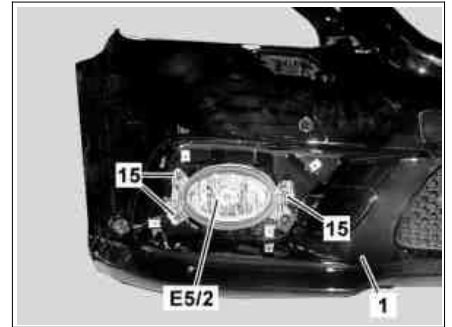

P88.20-3138-01

21 Insert mounting bolt on check strap cover (33) into front bumper paneling (1) and fasten to mounting bolt covers (34).

i Tie check straps on mounting bolt cover (33) on mounting bolt covers (34).

i Close mounting bolt covers (34) only after installing front bumper paneling (1) on vehicle.

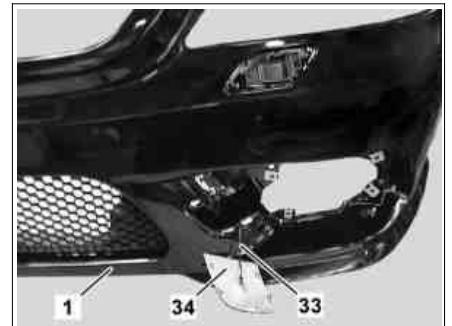

P88.20-3139-01

22 Insert left and right air inlet grate (27) into front bumper paneling (1) and fasten with four 3.5 x 22 round Allen head bolts (28) each.

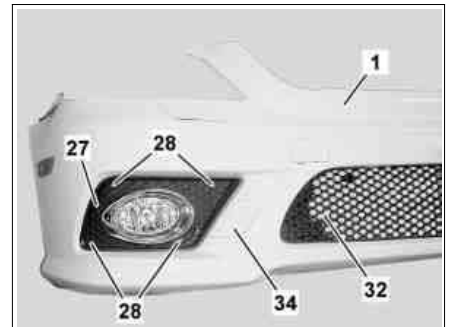

P88.20-3140-01

23 Install license plate frame (25) at outside of front bumper paneling (1) and prepare for assembly.

i Use license plate frame (25) as template for marking holes. The distance (a) between the outer edge of the license plate frame (25) and the center of the front bumper paneling (1) should be equal. Center license plate frame (25) (see picture at top) and align along contour of front bumper paneling (1) (see picture at bottom).

i Shown with license plate cover (25) for Japan.

24 Drill four holes for assembling license plate frame (25) and install license plate frame (25) on front bumper paneling (1) with four bolts (F5x18).

i Tighten bolts only with screwdriver.

i Shown with license plate cover (25) for Japan.

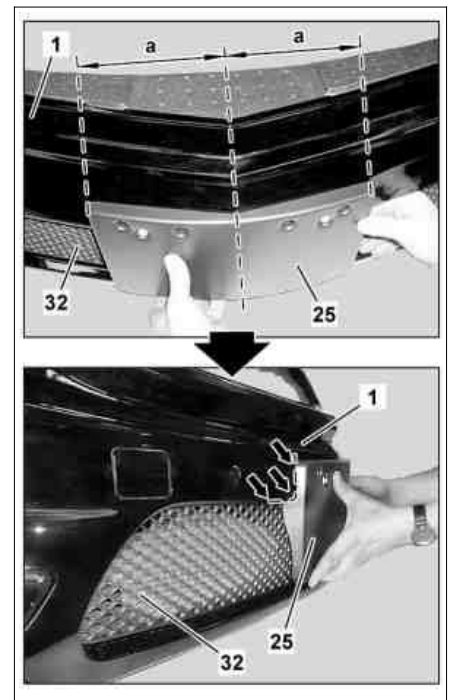

P88.20-3141-03