

**i** Check components removed from standard bumper before assembly and replace if damaged.

**ⓘ** Pay attention to paint damage.

1 Insert bottom section paneling (2) into rear bumper paneling (1) and arrest.

**i** When positioning insert paneling bottom section (2) on right and left at bottom into brackets on rear bumper paneling (1) (see circles).

**i** Check whether paneling bottom section (2) is arrested properly in rear bumper paneling (1) on inside, if applicable press again.

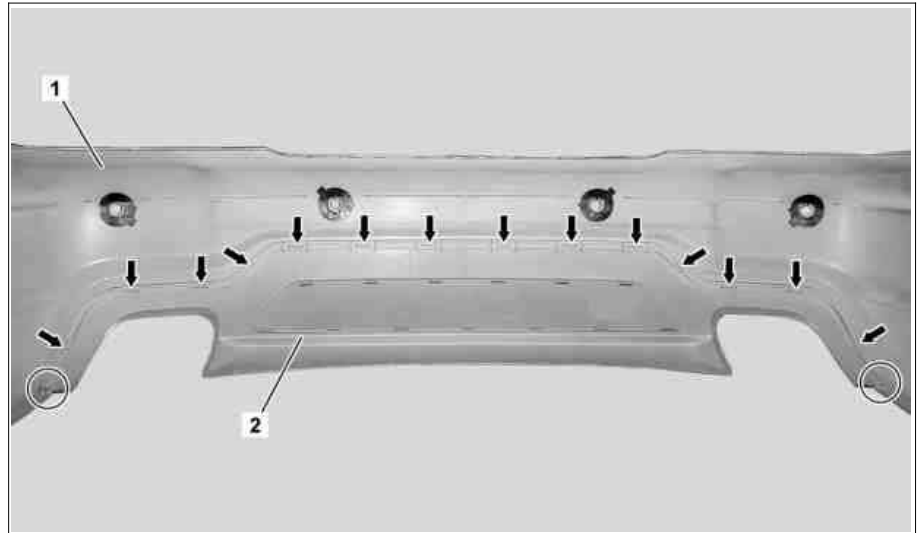

P88.20-3144-05

2 Insert air gate lower section (3) into paneling bottom section (2) and fasten on inside with 13 clips (12).

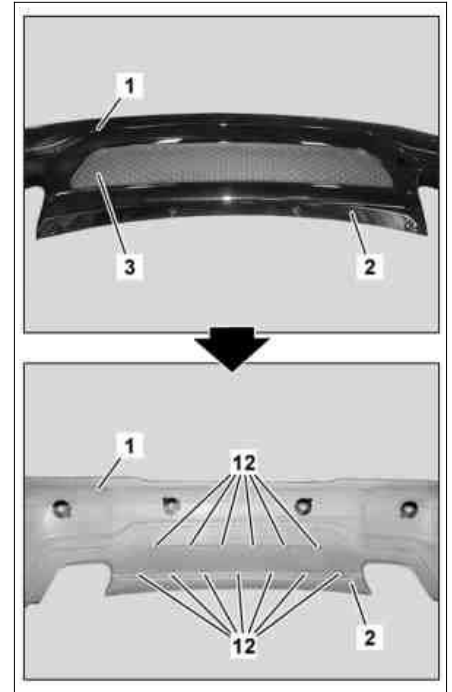

P88.20-3145-03

3 Insert left and right rear reinforcements (5) into rear bumper paneling (1) and fasten with one clip (12) each.

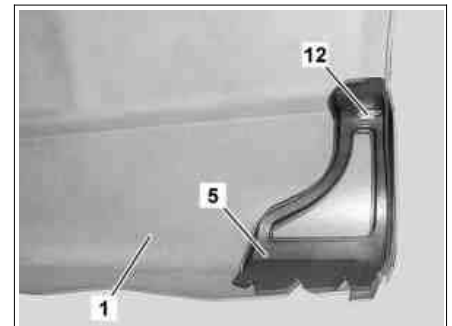

P88.20-3142-01

- 4 Insert left and right rear lateral supports (6) into rear bumper paneling (1) and fasten together with left and right rear reinforcements (5) with two blind rivets (13) each.

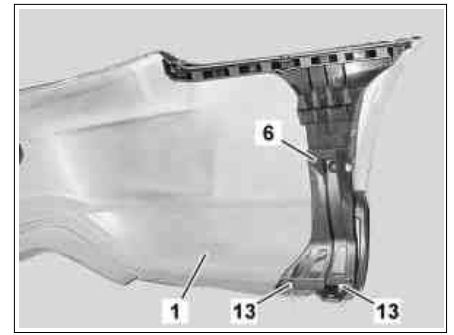

P88.20-3143-01

- 5 Insert rear frame segment (4) into rear bumper paneling (1) and arrest on inside (see arrows).

**i** Check whether the rear frame segment (4) is arrested properly in the rear bumper paneling (1), if applicable repress.

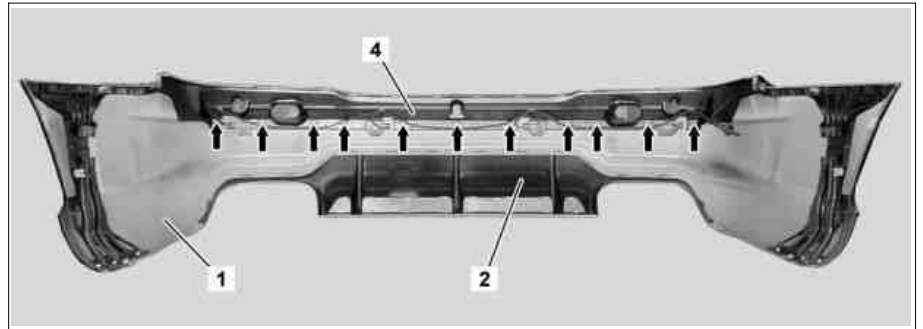

P88.20-3146-04

- 6 Fasten rear frame segment (4) and left and right rear lateral support (6) to upper edge of rear bumper paneling (1) with 16 expansion rivets.

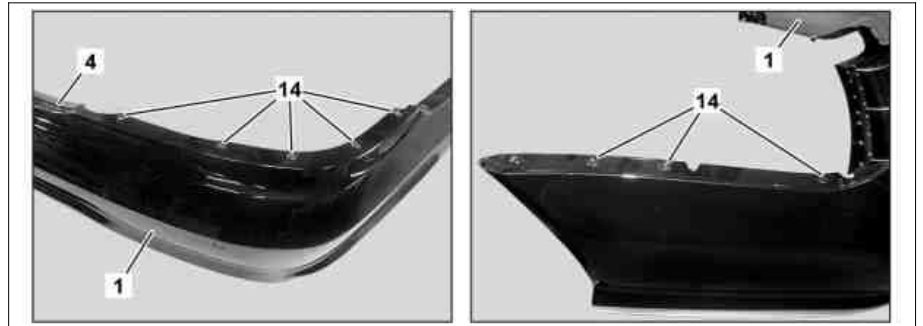

P88.20-3147-04

- 7 Install seal washers (15) on right and left on studs on rear frame segment (4).

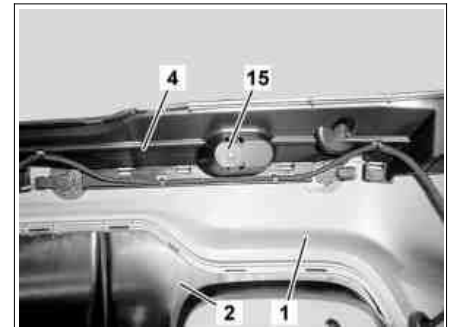

P88.20-3148-01

**Vehicles with Parktronic system (PTS) code 220**

- 8 Insert right rear outer PTS ultrasonic sensor (B8/7), right inner PTS ultrasonic sensor (B8/8), left inner PTS ultrasonic sensor (B8/9) and left outer PTS ultrasonic sensor (B8/10) into brackets on rear bumper paneling (1).

**i** Previously check whether a decoupling ring (transparent silicon ring) is installed on all PTS ultrasonic sensors.

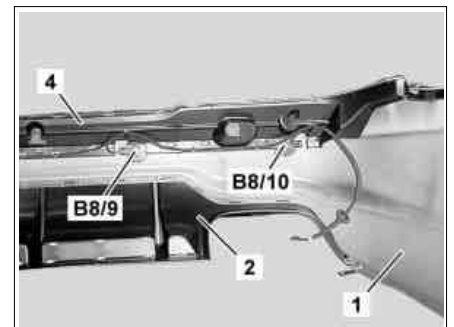

P88.20-3149-01

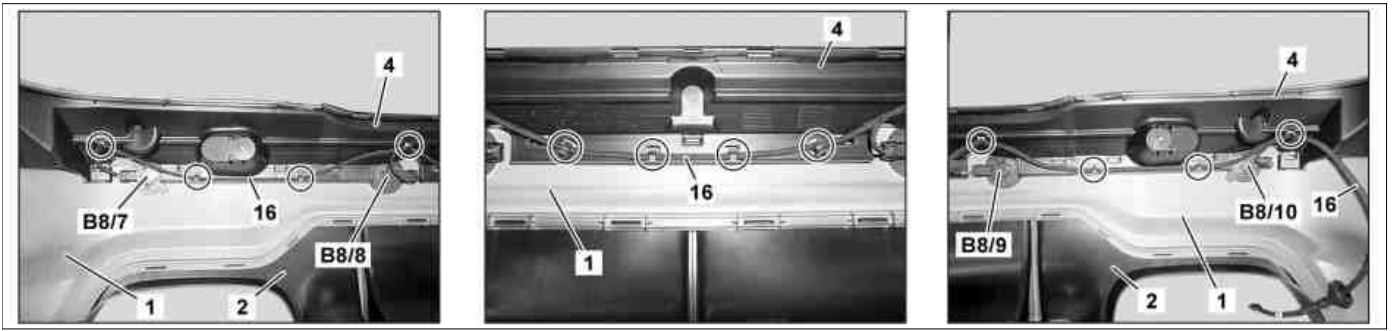

P88.20-3150-07

**Vehicles with Parktronic system (PTS) code 220**

- 9 Insert PTS wiring harness (16) into rear bumper paneling (1) and fix in place in specified attachment points (see circles).
- 10 Fasten bottom paneling bracket (17) to rear bumper paneling (1) with one sheet metal nut (18) each and one round Allen head bolt (19)

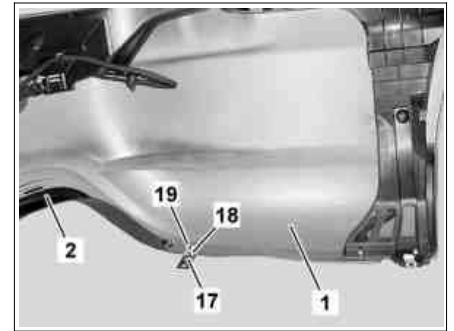

P88.20-3151-01