

FILE: SERVICE: GROUP 00 OF SERVICE INFORMATION BINDER
 PARTS: GROUP I OF INFORMATION - PARTS & ACCESSORIES BINDER

Campaign No. 2004050014

October 2004

TO: ALL MERCEDES-BENZ CENTERS

SUBJECT: **MODELS 211.065/070/076/082/083/026/265/283/282, 230.474/475/476
 MODEL YEARS 2003 THROUGH 2005
 PROGRAMMING SBC HYDRAULIC UNIT**

This Recall Campaign has been initiated because DCAG has determined that on the affected vehicles (see VIN range below), in certain instances, the Sensotronic Brake Control (SBC) pump motor may run out of permissible tolerances, thereby triggering the hydraulic back up function mode. In the hydraulic back up mode, the driver has braking power sufficient to stop the vehicle, although greater brake pedal pressure is required and the brake pedal travel will be noticeably longer which could lead to a vehicle crash. The recall will be conducted in order to re-program the SBC Hydraulic unit.

Please review the Effective Serial Number Chart located below.
 Attached is a sample copy of a letter which owners of the affected vehicles will receive.

Prior to performing this Recall Campaign:

- Please check VMI to insure the vehicle is involved and to determine if the vehicle has been previously repaired.
- Please review the entire Recall Campaign bulletin.

Approximately 140,387 vehicles are affected.

Effective Serial Number Range

Model	Chassis End Number	
	From	To
211	A014562	A586891
	X097696	X163060
230	F001748	F085469

Order No. P-RC-2004050014

This bulletin has been created and maintained in accordance with MBUSA-SLP S423QH001, Document and Data Control, and MBUSA-SLP S424HH001, Control of Quality Records.

Procedure

Note:

- Use STAR Diagnosis DAS software 09/2004 with the 2004-09-23-0295 patch installed (or later DAS release). As of DAS Release 10/04 the 2004-09-23-0295 patch is included within the DAS software.
 - Serial interface (COM1) on SDS must be free. In the event a device is connected to COM1, disconnect the device (from the SDS COM1 port) then shut down and restart SDS.
1. Visually inspect whether the pump motor of the SBC hydraulic unit has a white Q11 sticker on it. If this is the case, programming is not required. The vehicle can be returned to the customer without the need for additional work. If a Q11 sticker is not present, continue with procedure. To close out campaign for inspection only see Warranty Information on page 11.

Notes on programming the SBC control module:

- In order to avoid oscillations in the on-board power supply, no electrical devices must be switched on/off. Ensure all electrical consumers are switched off (e.g. radio, telephone, climate control) prior to programming the SBC control module.
- The programming will **not** be successful if the SBC control module has undervoltage when programming is taking place. For this reason, a battery charger **must** be connected before programming starts.

CAUTION!

If programming is aborted, the SBC control module **will no longer be operational!**

- Temperature of SBC hydraulic unit must be ≤ 50 ° C and ≥ 10 ° C. Programming with SDS is not possible if hydraulic unit temperature is out of range. **Do not** cool hydraulic unit with any other method than air cooling (e.g., open hood and allow unit to cool unassisted or cool unit by circulating air around it using a standing electric room fan).
2. Connect SDS to vehicle through the 16 pin diagnostic connector (X11/4).
 3. Switch ignition: **ON**.
 4. Perform short test, read and document fault memory then erase fault codes.

Note:

Prior to programming, ensure that there are no warning messages in the instrument cluster display. Take care of any customer complaints prior to programming the SBC control module.

5. Select Control Units adaptations in the SBC control module by navigating through the following screen menus in DAS: Control Units/Chassis/SBC - Sensotronic Brake Control/Control Unit Adaptations.

Note:

The DAS steps **MUST** be followed exactly as described in the previous step.

6. When the "Control Unit Adaptations" menu item is selected the parameters are updated and SDS checks whether the SBC control module requires programming.
 - If programming is not required, a white Q11 sticker must be affixed to the pump motor of the SBC hydraulic unit in a clearly visible position. The sticker must be applied to a clean surface. Disconnect SDS from vehicle. The vehicle can be returned to the customer.
 - If SDS indicates that control module software for updating has been found, continue with **step 6**.
 - Ensure that the vehicle has an adequate power supply (more than 12.5V) using a battery charger. Do not connect the negative terminal of the battery charger to the vehicle battery, but connect it to a vehicle ground instead.
 - Read and observe notes on control unit programming in DAS.

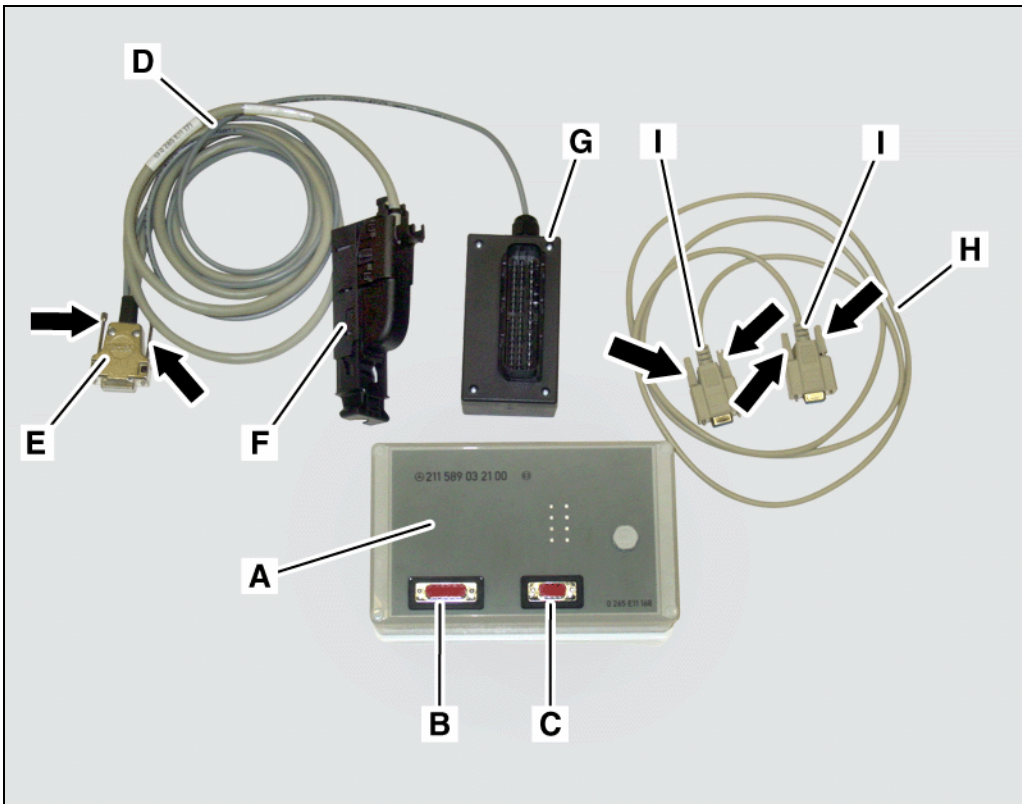

Figure 1

P43.00-2040-81

SBC module kit (ensure you have received all of the following components):

Arrows Connector thumb screws

- | | | | |
|----|------------------------------------|----|--|
| A. | SBC module box | E. | Adapter cable connector to module box (15 pin) |
| B. | SBC module box connector (15 pin) | F. | Adapter cable connector to SBC hydraulic unit |
| C. | SBC module box serial port (9 pin) | G. | Adapter cable connector to engine harness (47 pin) |
| D. | Adapter cable | H. | Serial cable |
| | | I. | Serial cable connector ends |

7. Press F2:
The vehicle will now be checked with regard to the SBC hydraulic unit voltage supply and temperature.
8. Connect adapter cable connector (A, Figure 2) to connector (B, Figure, 3) on the SBC module box (A, Figure 3) and secure connector (A, Figure 2) using thumb screws (arrows).

Note:

Ensure that the connection is correctly seated by fully tightening the thumb screws (arrows).

⚠ CAUTION!

The SBC module box (A, Figure 3) must be positioned in a location where the adapter cable (B, Figure 2) cannot come into contact with rotating engine parts.

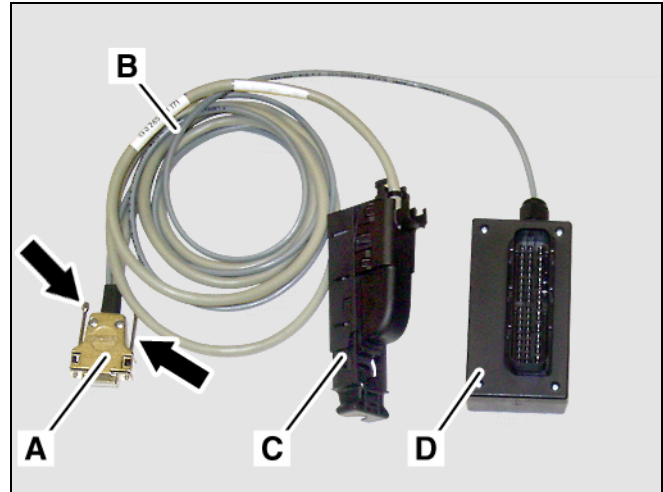

Figure 2

P43.00-2041-71

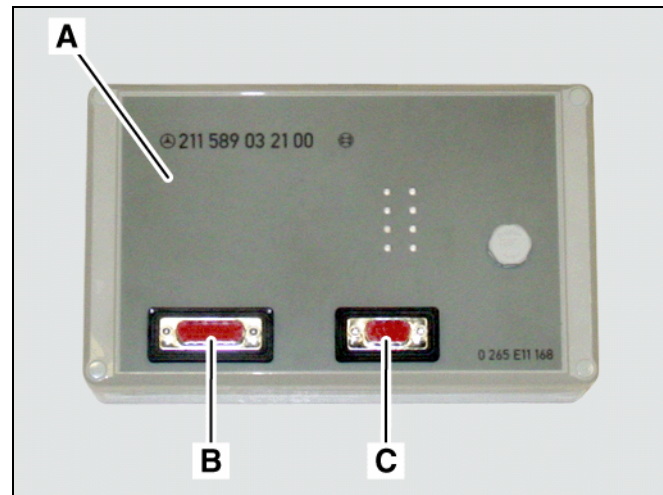
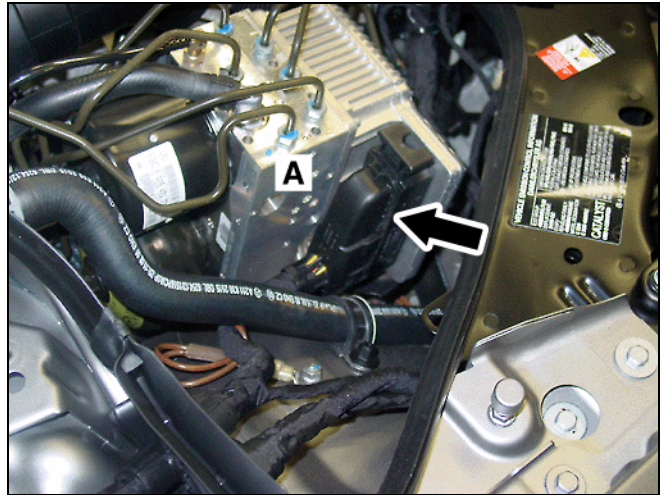

Figure 3

P43.00-2042-71

9. Disconnect engine wiring harness connector (arrow, Figure 4) from SBC control module (A).
10. Connect and lock 15/47-pin adapter cable connector (A, Figure 5) to engine wiring harness connector (B).
11. Connect and lock 15/47-pin adapter cable connector (C, Figure 5) to SBC control module (D) connector.
12. Press F2.

**Figure 4**

P43.00-2043-71

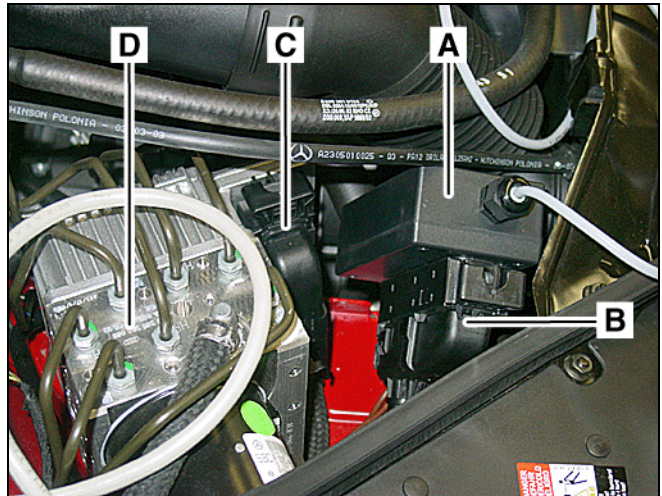
**Figure 5**

P43.00-2044-71

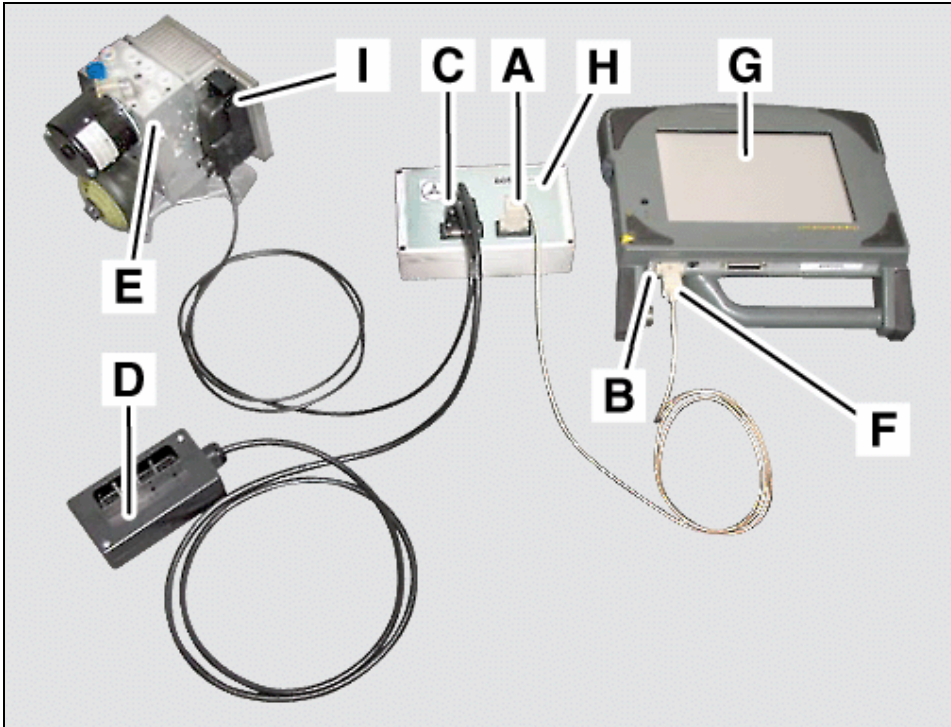

Figure 6

P43.00-2045-71

SBC module box kit cable connections

A	Serial cable connector end	F	Serial cable connector end.
B	SDS serial interface (COM 1) 9 pin connector	G	SDS Basic
C	Adapter cable connector to module box (15 pin)	H	SBC Module box
D	Adapter cable connector to engine harness (47 pin)	I	SBC hydraulic unit connector
E	SBC hydraulic unit (shown out of vehicle)		

13. Connect SDS and SBC module:

- Connect one end of serial cable connector (A, Figure 6) to serial port on the SBC module box (H) and secure using thumb screws.
- Connect the other end of serial cable connector (F, Figure 6) to serial interface COM1 (B) on SDS (G).

Note:

Refer also to Figures 7 and 8 for location of SDS serial interface locations.



Figure 7 P43.00-2046-71
SDS serial interface COM1 (arrows, Figures 7, 8)



Figure 8 P43.00-2047-71

Note:

- Ensure that both ends of the serial connector are correctly seated by fully tightening the thumb screws.
- Ensure that the cable connection from SDS to the 16-pin diagnostic connector (X11/4) on the vehicle is not interrupted.

14. To continue procedure, press **F2** and follow the DAS instructions.

15. Start programming by pressing **F3**.

Note:

- Programming takes approx. 2.5 to 3 minutes. Do not disrupt procedure while in progress.
- Follow DAS instructions.
- If programming was unsuccessful, an error message will appear. Other SDS actions may be requested depending on the error messages.
- If the COM1 port on SDS is not enabled, the vehicle cannot be programmed.

16. Following programming, remove the adapter cable (15-/47-pin) and the serial cable (9-pin) from SDS and the SBC module box. Reconnect engine wiring harness connector to SBC hydraulic unit.

Note:

Ensure that the cable connection from SDS to the 16-pin diagnostic connector (X11/4) on the vehicle is not interrupted.

17. Press **F2**. The programming of the SBC control module will now be checked.

Note:

- The programming of the SBC control module causes various fault codes to be stored in other control modules. For this reason, step 18 must be performed after the SBC control module has been successfully programmed.
- If programming is successful DAS will display:
“Result: Programming of control module successfully completed”.

18. Perform short test, erase fault memory.

19. Attach Q11 sticker to the pump motor of the SBC hydraulic unit in a clearly visible position. The sticker must be applied to a clean surface.

20. For vehicles:

- Model 211:
 - ◆ Up to chassis end number A 279 911, X102 857 continue to step 21 (bleed hydraulic braking system).
 - ◆ As of chassis end number A 279 912, X102 858 continue to step 23 (brake bleeding not required).
- Model 230:
 - ◆ Up to chassis end number F 066 278 continue to step 21 (bleed hydraulic braking system)
 - ◆ As of chassis end number F 066 279 continue to step 23 (brake bleeding not required).

21. Bleed hydraulic braking system (refer to WIS: AR42.10-P-0012R). Navigate through the Following screen menus in DAS to perform bleeding and follow on-screen instructions: Control units/Chassis/SBC/ General servicing/Replace brake system fluid /Bleed brake system (follow on-screen instructions).

 **WARNING!**

Use **only** Special Tool: EHB adapter (part no. 240 589 00 91 00) when bleeding brakes. **DO NOT** use any other part no. regardless of what is indicated in DAS.

Note:

Remove all four wheels on the following models when bleeding brakes: 211.076, 230.474/476

22. Inspect brake system for air. Navigate through the Following screen menus in DAS to inspect brake system for air and follow on-screen instructions: Control units/ Chassis/SBC/ General servicing/Inspect brake system for air (follow on-screen instructions).

23. Disconnect SDS from vehicle.

Note:

All Sensotronic Brake Control diagnosis and/or repair must be performed utilizing STAR Diagnosis DAS software 09/2004 with the 2004-09-23-0295 patch installed (or later DAS release) or erroneous diagnosis may occur.

24. Disconnect battery charger

Note:

- If SDS indicates that the SBC hydraulic unit must be replaced, proceed as described in WIS AR42.46-P-0010R. All the steps described therein **must** be followed.
- If the instrument cluster's odometer displays "-----", instead of actual mileage, then the instrument cluster will need to be reinitialized. In order to reinitialize the instrument cluster navigate through the following DAS menus: Control units/Information and communication/IC-Instrument cluster. Once the Instrument Cluster menu is selected, DAS will automatically prompt instrument cluster initialization (follow on screen instructions).
- The replacement parts department ensures that only the latest version of the SBC hydraulic unit will be delivered. These units no longer require programming.

Special Tools

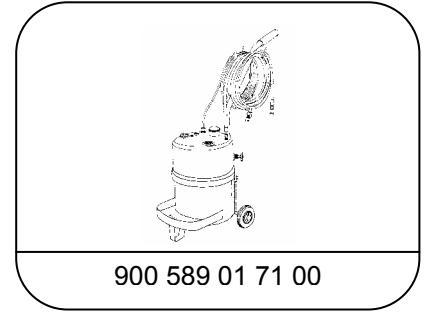
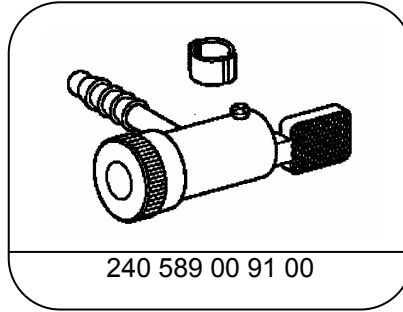

Note:

These are Required Special Tools that will be automatically released 1 per Mercedes-Benz dealer in conjunction with this Recall.

Parts Information

Qty.	Part Name	Part Number
1	SBC hydraulic unit	A005 431 68 12 05 (Model 211) ¹⁾
	⚠ CAUTION!	A005 431 34 12 05 (Model 211) ²⁾
	Refer to parts ordering information below to determine the correct SBC hydraulic unit to install	A005 431 68 12 05 (Model 230) ³⁾
		A005 431 34 12 05 (Model 230) ⁴⁾
1	Sheet of Q11 stickers (40 stickers per sheet) ⁵⁾	A 211 584 00 07
2.25 liters	Brake fluid ⁶⁾	A 000 989 08 07 01

Parts Notes:

- **SBC Hydraulic unit ordering information:**

For **model 211**, determine the correct part to install by viewing which part number is installed in the vehicle:

¹⁾ If the installed unit is marked A004 431 43 12, A004 431 98 12, A004 431 42 12 or A004 431 97 12, then install the **A005 431 68 12 05**, and be sure to bleed the system.

²⁾ If the installed unit is marked A004 431 70 12, A005 431 00 12, A005 431 06 12, A004 431 69 12, A004 431 99 12 or A004 431 05 12, then install **A005 431 34 12 05**

For **model 230**, determine the correct part number by VIN:

³⁾ Up to VIN F049658 (Production Date March 4, 2003) install **A005 431 68 12 05** and bleed the system

⁴⁾ From VIN F049659 up to MY 2005 (Code 805), Install **A005 431 34 12 05**.

- **Q11 stickers:**

Please only order the number of sheets of Q11 stickers that are actually required; note that each sheet contains 40 Q11 stickers.⁵⁾ Submit as local purchase "QLABEL00008" quantity of 1. (handling is included).

- **Brake fluid:**

⁶⁾ Submit as local purchase "Bkfluid00551" quantity of 3. (handling is included).

Note:

The following allowable labor operation should be used when submitting a warranty claim for this repair:

Warranty Information

Operation: Expanded short test, perform (02-4416)
 Control unit - program, perform (02-4425)
 Hydraulic brake system, Bleed (if necessary) (02-4566)
 SBC hydraulic unit, (includes bleeding) replace (if necessary) (02-4390)
 Inspect for Q11 label. No further repair required (42000001)

All Vehicles

Damage Code	Operation Number	Labor Time (hrs.)	Model Indicator(s)
43 910 27	02-4416	0.4 hrs.	R0, T0, U0
	02-4425	0.4 hrs.	R0, T0, U0
	02-4566 *	1.0 hrs.	T1, T2, T4, T5, T6, U1, U3, U4, R1
		1.6 hrs.	T3, R2, R3

* In addition, if vehicle falls in the following Serial Number Range add this operation to claim

Chassis End Number

From To
 A 014562 – A 279911
 X 097696 – X 102857
 F 001748 – F 066278

In the rare occurrence when the vehicle requires replacement of the SBC hydraulic unit submit the claim as follows:

Damage Code	Operation Number	Labor Time (hrs.)	Model Indicator(s)
43 910 27	02-4416	0.4 hrs.	R0, T0, U0
	02-4425	0.4 hrs.	R0, T0, U0
	02-4390	3.8 hrs.	R0, T0, U0

In the rare occurrence when the Q11 label is found on the pump motor submit the claim as follows to close campaign:

Damage Code	Operation Number	Labor Time (hrs.)	Model Indicator(s)
43 910 27	42000001	0.2 hrs	R0, T0, U0

Note:

All replaced SBC hydraulic units **must** be returned to the Quality Evaluation Center (QEC) indicated by NetStar parts disposition. Each returned SBC hydraulic unit **must include** a printout of the STAR Diagnosis test "Check operating time of component A7/3 (SBC hydraulic unit)". In order to obtain a printout navigate through the following STAR Diagnosis menus: [Control Units-->Chassis-->Sensotronic Brake Control (SBC)-->General Servicing-->Check Operating Time Of Component A7/3 (SBC Hydraulic Unit)]. Warranty claims filed for Sensotronic Brake, after October 26, 2004, without including the STAR Diagnosis printout will be debited and the corresponding parts will be sent back to the dealer.

NOTE REGARDING CUSTOMER REIMBURSEMENT

Reimbursement to customers for repairs performed prior to this recall:

If the customer already paid to have this recall condition repaired and provides adequate documentation to support their claim of a non-warranty repair of this item, they may be eligible to receive reimbursement.

Requests for reimbursement may include parts, labor, fees and taxes. Reimbursement may be limited to the amount the repair would have cost if completed by an authorized Mercedes-Benz dealer.

See "Reimbursement to Customer for repairs performed prior to recall" in MBUSA's Warranty Policy and Procedures Manual.

Please note the claim submitted for customer reimbursement will **not** close the campaign (if still open).

If the customer is still in possession of the vehicle with an open campaign, please arrange to close the recall in the usual manner.

Safety Recall #2004 0500 14

October, 2004

Dear Mercedes-Benz Owner

This notice is sent to you in accordance with the requirements of the National Traffic and Motor Vehicle Safety Act. WE SENT YOU THIS NOTICE BECAUSE WE ARE CONCERNED ABOUT YOUR SAFETY.

DaimlerChrysler AG (DCAG), the manufacturer of Mercedes-Benz vehicles, has decided that a defect which relates to motor vehicle safety exists in certain Model Year 2003 – 2005 E-Class and 2003 – 2004 SL-Class vehicles equipped with Sensotronic Brake Control (SBC). Mercedes-Benz USA, LLC (MBUSA) therefore has initiated a recall of these vehicles. Our records indicate that your vehicle is included in this group.

DCAG has determined that in certain instances the pump motor may run out of permissible tolerances, thereby triggering the hydraulic back up function mode. In the hydraulic back up mode, the driver has braking power sufficient to stop the vehicle, although greater brake pedal pressure is required and the brake pedal travel will be noticeably longer which could lead to a vehicle crash.

Your authorized Mercedes-Benz dealer has an available software upgrade that corrects the situation described above.

If you are no longer the vehicle owner, or have a change of address, please complete the reverse side of this letter and return the complete letter in the enclosed envelope. If this is a leased vehicle and the lessor and registered owner receive this notice, please forward this information by first class mail to the lessee. If you have paid to have this recall condition corrected prior to this notice you may be eligible to receive reimbursement. Please see the reverse side of this notice for details.

Please contact your authorized Mercedes-Benz dealer should you have any questions or encounter any difficulty regarding this recall. If your dealer is unable to remedy your situation please contact us at 1-(800) FOR-MERCedes (1-800-367-6372).

If an authorized Mercedes-Benz dealer or Mercedes-Benz USA, LLC, fails or is unable to perform this service without charge within 60 days, pursuant to law 49 U.S.C. Chapter 301, you may submit a complaint to the Administrator, National Highway Traffic Safety Administration, 400 Seventh Street, S.W., Washington, D.C. 20590 or call the toll-free Auto Safety Hotline at 888-327-4236.

Again, we apologize for any inconvenience this situation may cause you.

Sincerely

Klaus Ulkann
Vice President, Customer Services

P-RC-2004050014