

FILE: SERVICE: GROUP 00 OF SERVICE INFORMATION BINDER
PARTS: GROUP I OF INFORMATION – PARTS & ACCESSORIES BINDER

Campaign No. 2005070007, May 2006

Revision History

Revision	Date	Purpose
E	05/05/06	Update of warranty information for SBC unit replacement
D	04/05/06	Addition of 3 new non-campaign damage codes for SBC unit replacement
C	01/12/06	Update of SBC connector information and clarification of SBC unit part numbers
B	12/06/05	Addition of Quality Assurance measures; update of work instructions and warranty
A	08/29/05	Breakdown of parts into primary and secondary; addition of replacement rates
-	08/02/05	Initial issue

TO: ALL MERCEDES-BENZ CENTERS

SUBJECT: **MODELS 211, 230**
MODEL YEAR 2004
INSPECT SBC HYDRAULIC UNIT, REPLACE AS DIRECTED

This Recall Campaign has been initiated because DCAG has determined that on the affected vehicles (see VIN range below) the SBC brake system may shift to the hydraulic back up mode due to the loosening of the ground wire harness connection over time, or due to premature failure of the hydraulic pump. On Model 211, dealers will install a bracket and replace the ground wire, and if required, replace the hydraulic pump and suction hose. On Model 230, dealers will install a bracket and replace the ground wire, replace the suction hose, and if required replace the hydraulic pump.

Note:

This recall campaign has been divided into two parts:

- I MODEL 211**
INSPECT SBC HYDRAULIC UNIT, REPLACE AS DIRECTED (PAGES 3-21)
- II MODEL 230**
INSPECT SBC HYDRAULIC UNIT, REPLACE AS DIRECTED (PAGES 22-39)

Note:

With the launch of this campaign, 211 and 230 vehicles subject to last year’s SBC Recall Campaign No. 2004050014 that have not been repaired to date have been excluded from last year’s campaign and will no longer appear in VMI as an “Open” campaign. All vehicles subject to last year’s SBC recall, both “Open” and “Closed” will be campaigned under this year’s SBC campaigns.

Please review the Effective Serial Number Chart located below.

Attached is a sample copy of a letter which owners of the affected vehicles will receive.

Prior to performing this Recall Campaign:

- Please check VMI to insure the vehicle is involved and to determine if the vehicle has been previously repaired.
- Please review the entire Recall Campaign bulletin.

Approximately 15,979 vehicles are involved.

Order No. P-RC-2005070007

This bulletin has been created and maintained in accordance with MBUSA-SLP S423QH001, Document and Data Control, and MBUSA-SLP S424HH001, Control of Quality Records.

Effective Serial Number Range

Models	Chassis End Number	
	From	To
211.006	A470365	A475255
211.026	A470992	A508719
211.061	A461620	A461620
211.065	A457431	A511132
211.070	A457447	A511135
211.076	A457425	A510794
211.082	X119124	X123272
211.083	X119111	X123267
211.206	A465748	A465748
211.265	A457426	A510952
211.282	X119113	X123268
211.283	X119110	X123264
230.474	F070784	F077518
230.475	F070783	F077529
230.476	F070797	F077483

Note:

Every vehicle in the VIN range may not be included in the campaign. VMI must always be checked before performing campaigns to verify that the campaign is required on a specific vehicle. VMI **always** overrides the bulletin in reference to a specific vehicle's inclusion in a particular campaign. Please also note that Recall and Service Campaigns **do not expire** and may also be performed on a vehicle with a vehicle status indicator.

**I MODEL 211
INSPECT SBC HYDRAULIC UNIT, REPLACE AS DIRECTED**

Procedure

A. INSPECTION OF SBC HYDRAULIC UNIT

1. Check if part number (A, Figure 1) is listed in the table below:
 - If the part number (A) **is** listed, proceed to step 2.
 - If the part number (A) is **not** listed proceed to step 3.

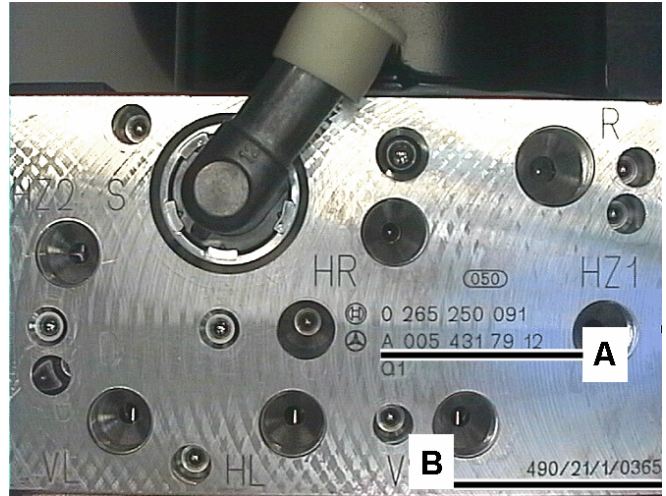

Figure 1

2. Check (refer to table below) if the production number (B, Figure 1) is within the listed production number range for the relevant part number (A):
 - If the production number (B) is **not** within the production number range proceed to step 3.
 - If the production number (B) **is** within the production number range compared to the relevant part number; proceed to Subject **B**, Replacement of SBC Hydraulic unit.
(E.g., for SBC hydraulic unit part number: A 005 431 68 12. The production number 392/08/1/0500 is not within the number range – proceed to step 3. The production number 392/11/1/0700 is within the number range – proceed to Subject B, Replacement of SBC Hydraulic unit).
3. Do **not** replace SBC Hydraulic unit or the suction hose. Only perform the installation of ground wires and bracket to the SBC wiring harness. Proceed to Subject B and perform the following steps **only**: 1-4, 11-24, 27-30, 32-33.

Note:

Perform step 24 (“Install clamp-on mounting bracket”) only if SBC hydraulic unit does not have connector mounting bracket bores machined into side of SBC unit.

Table

Part number	Production number	
	From	To
A 005 431 68 12	392/09/1/0496	392/12/1/0641
A 005 431 05 12	391/24/1/0680	481/08/1/0290
A 004 431 82 12	392/10/1/0244	392/18/1/1198
A 005 431 06 12	392/01/1/1152	481/08/1/0165
A 004 431 83 12	392/08/1/0525	392/08/1/0534

Note:

When reading the production number (B, Figure 1) on the SBC hydraulic pump, disregard the slashes.

The production number should be read as a whole number:

e.g., 392/08/1/0534 = 3,920,810,534

B. REPLACEMENT OF SBC HYDRAULIC UNIT (MODEL 211)

⚠️ WARNING!

Risk of injury caused by body parts being pinched or crushed. Risk of injury to skin and eyes caused by brake fluid spraying out at high pressure when working on the SBC brake system.

Risk of poisoning from swallowing brake fluid.

Pour brake fluid only into suitable and appropriately marked containers. Wear protective clothing and eye protection when handling brake fluid.

1. Deactivate SBC using Star Diagnosis.
2. Disconnect SBC hydraulic unit harness connector (C, Figure 2).
3. Remove mounting strap (A, Figure 2) and reposition hose and strap (A) to create more working space.
4. Detach SBC hydraulic unit ground wire (arrow, Figure 2) at terminal stud (B).
5. Position harness connector (C, Figure 2) away from SBC hydraulic lines to prevent brake fluid from dripping on SBC harness connector and SBC wiring harness.
6. Remove SBC hydraulic unit refer to WIS: AR42.46-P-0010R, steps 1 - 3, 5 - 14.
7. Remove combination filter housing, refer to WIS: AP83.00-P-8384TA (do not replace combination filter).

8. Remove suction hose (A, Figure 3):
 - Remove and discard hose clamp (arrow) where suction hose is connected to suction line (B).

⚠️ CAUTION:

Do not use sharp-edged tools (e.g., screwdriver) to remove suction hose (A, Figure 3) from SBC suction line (B), this may cause damage to the suction line (B) and possible SBC brake system malfunctions.

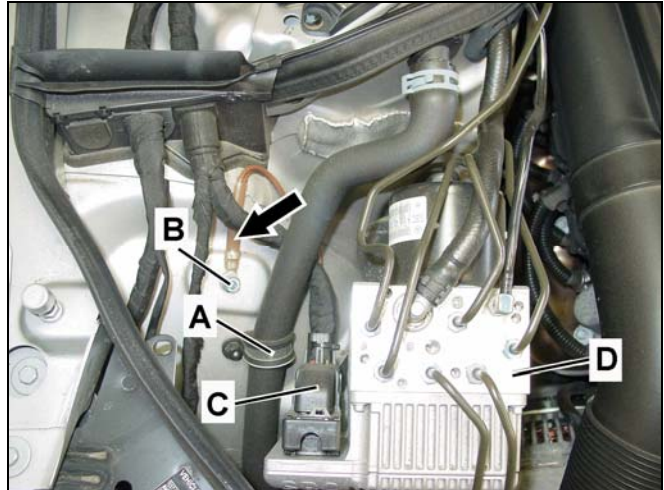

Figure 2

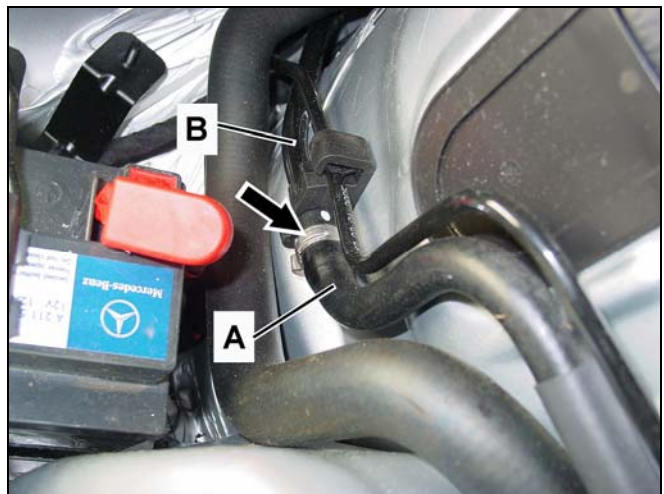

Figure 3

- Carefully detach suction hose (A, Figure 3) from the suction line (B) using a plastic wedge (Example: Special Tool: W110 589 03 59 00).

Note:

- When removing suction hose (A, Figure 3), do not bend suction line.
- To prevent brake fluid from running out and to prevent contamination in the brake system, the suction hose (A, Figure 3) and line (B) are to be plugged using suitable plugs from the stop plug kit (Special Tool: W129 589 00 91 00).
- Discard old suction hose (A) and clamp (arrow) after removal.



Figure 4

- Check if a pulsation damper (B, Figure 4) was installed on suction hose:
 - If pulsation damper (B) was **not** installed: Install new standard suction hose (A) to suction line, secure with new hose clamps (arrows).
 - If pulsation damper (B) **was** installed: Install new suction hose (A) with double pulsation damper to suction line, secure with new hose clamps (arrows).

- Reinstall combination filter housing in reverse order.

- Remove cable tie (arrow, Figure 5) securing SBC wire harness (A) to SBC connector housing (B).

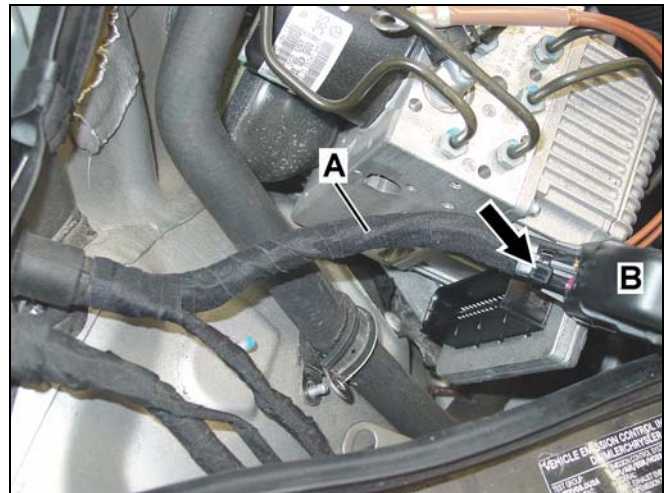

Figure 5

12. Remove fabric tape (circled area, Figure 6) from wire harness up to rubber grommet.

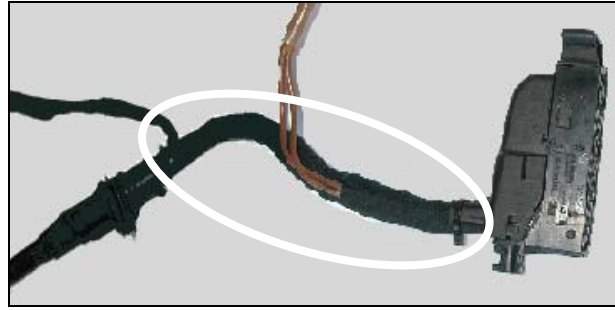

Figure 6

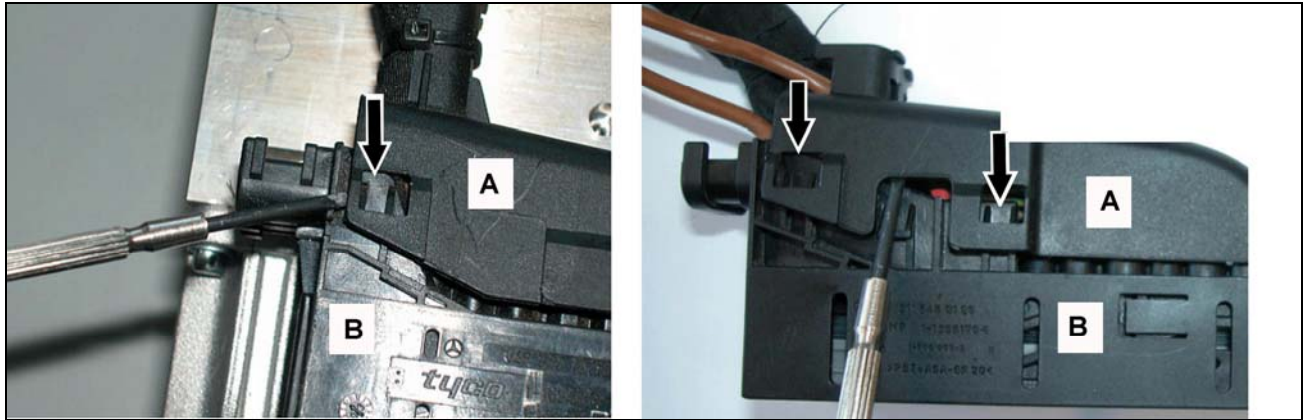

Figure 7

13. Remove SBC connector housing (A, Figure 7) cover:

- Using a small screwdriver, carefully pry cover (A) away from locking lugs (arrow) until it disengages.
- Repeat the process on opposite side.
- Remove the cover (A) from the housing (B).

Note:

There are two different versions of the SBC wiring harness connector (Figure 8a, b) installed in vehicles involved with this campaign.



Figure 8a (Connector Type A)

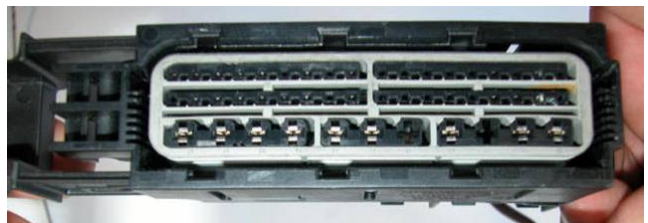

Figure 8b (Connector Type B)

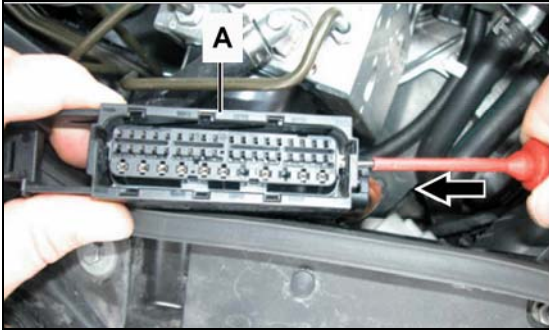

Figure 9a (Connector Type A)

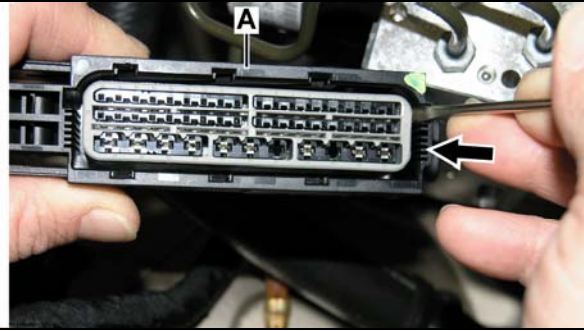

Figure 9b (Connector Type B)

14. Open the (gray) secondary lock in the SBC connector housing (A, Figure 9) by sliding the lock in the direction indicated by the arrows (Figure 9) using a small screwdriver.

15. Remove ground wires (arrows, Figure 10) from SBC harness connector (A):

- Unpin SBC ground wire connectors (position 37 and 44, Figure 10) using cable release tool and remove from SBC connector housing (A) (Special Tools: W 000 589 13 99 30 and W 220 589 01 99 50).
- Discard old ground wire harness, it is no longer needed.

16. Insert the new ground wiring harness (arrows Figure 10) into the SBC connector housing (A):

- Insert **longer** ground wire into position 44.
- Insert **shorter** ground wire into position 37.

Note:

Ensure ground wire connectors are **properly** locked into place.

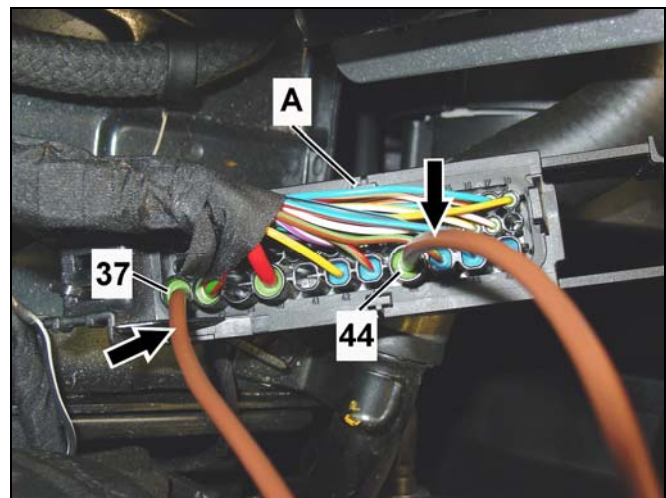

Figure 10

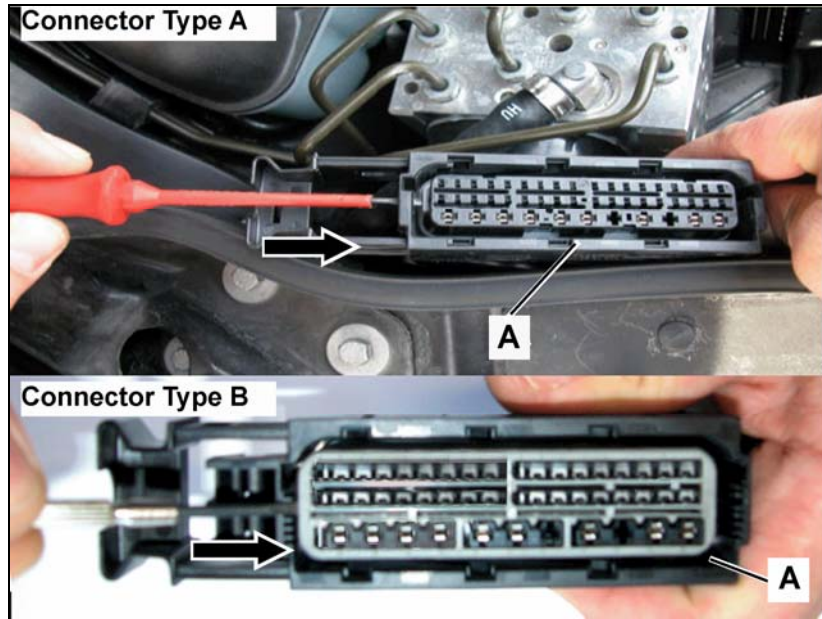

Figure 11

17. Close the (gray) secondary lock of the SBC connector housing (A, Figure 11) by sliding the lock in the direction indicated by the arrows (Figure 11) using a small screwdriver until it locks into place.
18. **Loosely** wrap the exposed SBC wire harness using fabric tape (arrows, Figure 12). **Do not** wrap the ground wiring harness (A) into the SBC wire harness.

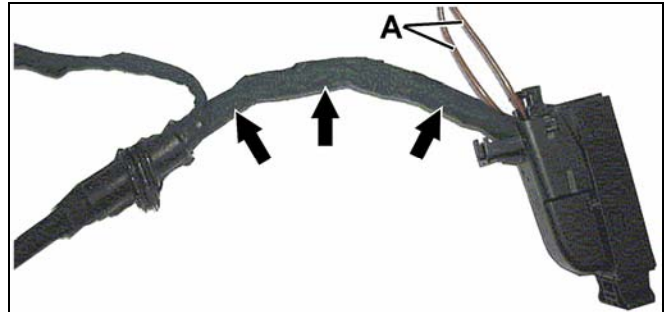

Figure 12

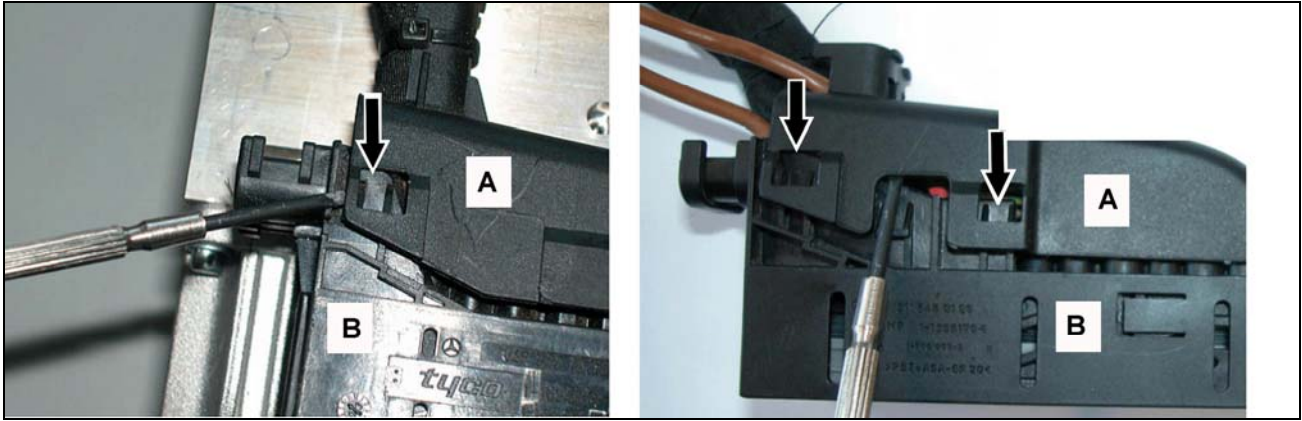

Figure 13

19. Reinstall the SBC wire harness connector cover (A, Figure 13) in reverse order.

Note:

Ensure the locking lugs (arrows) on the harness connector (B) are properly engaged into the harness connector cover (A).

20. Secure the SBC wiring harness (A, Figure 14) (**excluding** ground wiring harness) to the SBC connector cover harness receptacle (D) using a new cable tie (arrow).

Note:

- Ensure that the SBC wiring harness (A) is properly routed so that it is free of tension in the SBC connector housing.
- The cable tie “buckle” (C) **must be located on the side of the connector cap harness receptacle (D) as depicted.**

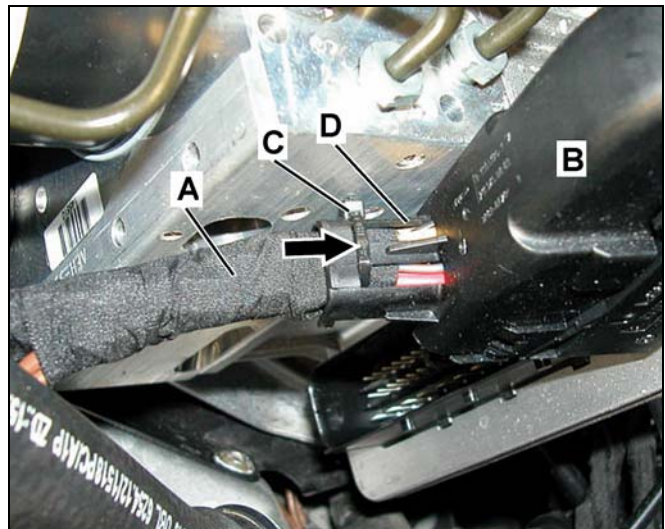

Figure 14

21. Secure ground wiring harness (arrow, Figure 15) to SBC wire harness (A) using two layers of fabric tape (B) in the circled area. Start taping approximately 35 mm ($X = 35$ mm, Figure 15) from end of connector cover receptacle (C).

Note:

See last bullet of step 33 note concerning fabric tape placement.

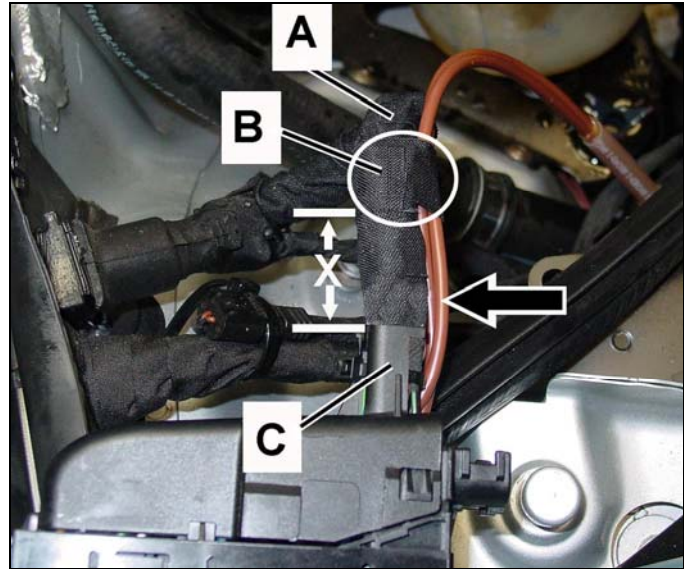

Figure 15

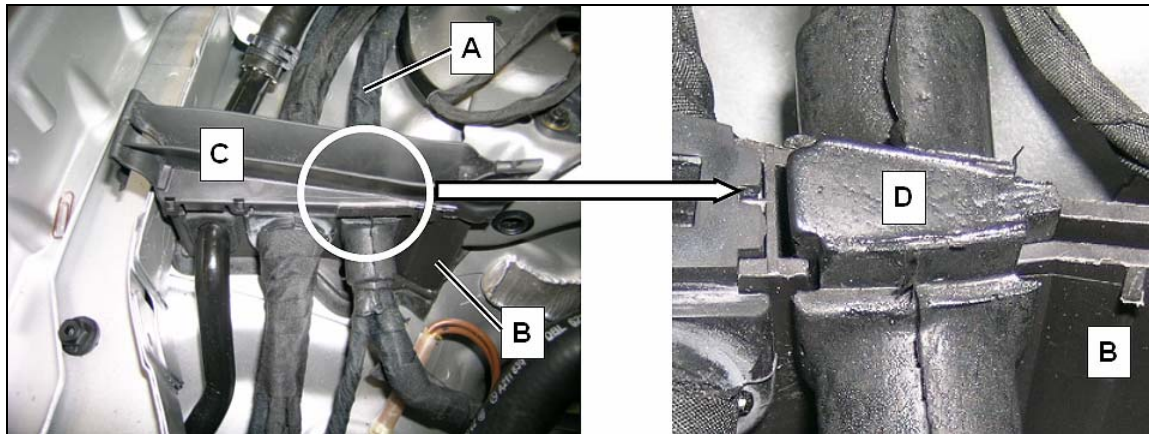

Figure 16

22. Remount the SBC wiring harness (A, Figure 16) in the wire harness guide (B):

- Remove wire harness guide cover (C) and remove SBC wiring harness with grommet (D) from harness guide (B).

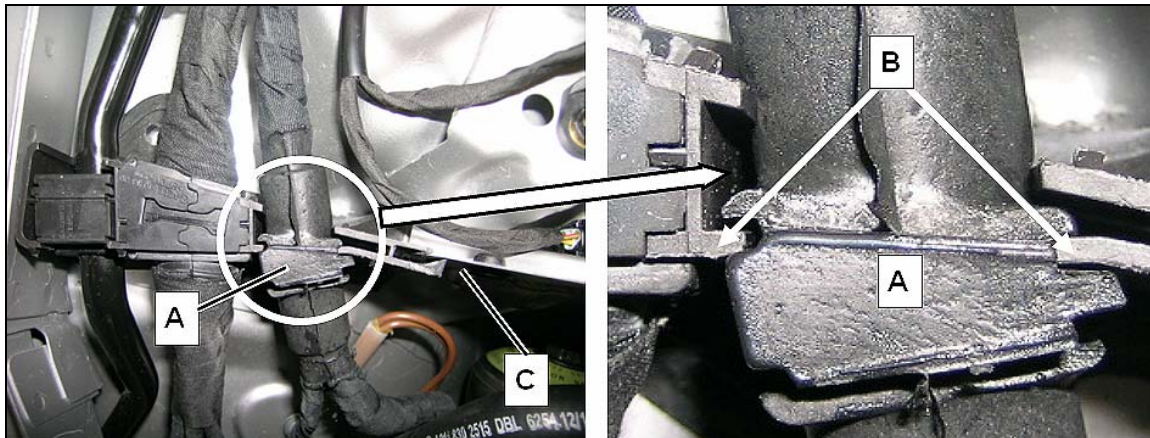

Figure 17

- Reposition SBC wiring harness with grommet (A, Figure 17) into the forward wall opening (B) in the wire harness guide (C).

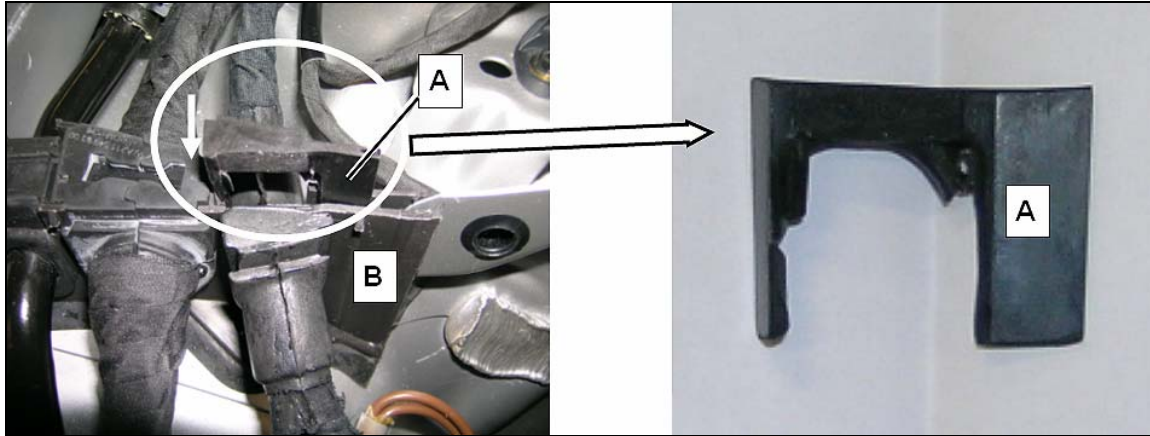

Figure 18

- Insert new routing clip (A, Figure 18) into wire harness guide (B) until top of clip (A) is flush with top of wire harness guide (B).
- Reinstall top of wire harness guide (C, Figure 16).

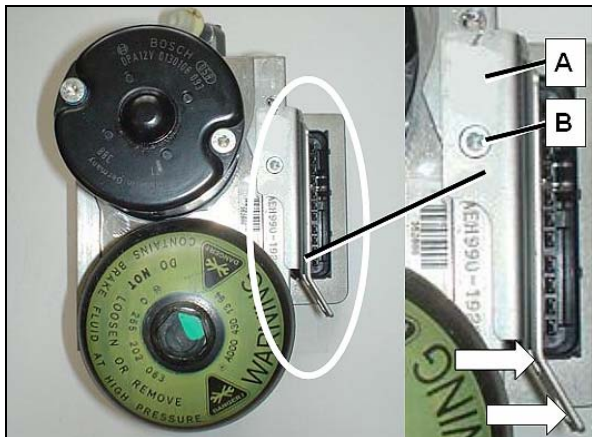

Figure 19



Figure 20

23. Attach SBC harness mounting bracket to the SBC hydraulic unit:

- Using hand tools, tap threads into SBC hydraulic unit bores by running self tapping screw (B, Figure 19) into lower bore **without** mounting bracket positioned on SBC unit.

Note:

- In order to avoid breaking the self-tapping screw (B) during installation, the screw (B) must be **positioned absolutely straight**
- Do not use power tools to install self tapping screw.
- In the event self tapping screw (B) is broken during installation of bracket (A) perform step 24 then continue with campaign (installation of bracket due to breakage of mounting screw will **not** be covered under warranty).
- Remove self tapping screw (B)
- Position bracket (A) on SBC hydraulic unit, reinstall self tapping screw (B) and **torque to 7 Nm**.

24. Install clamp-on mounting bracket (B, Figure 21) if necessary due to broken self-tapping screw:

- Position mounting bracket (B) onto SBC hydraulic unit (A) as shown in Figure 21.

Note:

Ensure mounting bracket (B) is flush with SBC hydraulic unit (A).

- Torque mounting clamp screw (C) to 5 Nm while pressing bracket (B) onto SBC unit (A) (proceed to step 27).

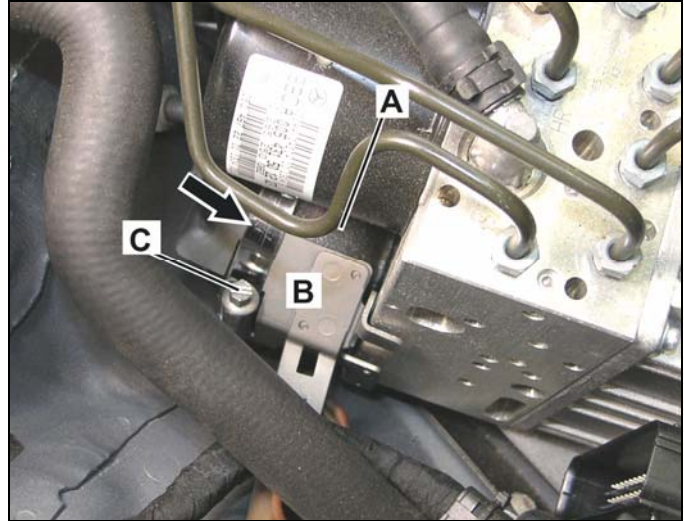

Figure 21

25. Install new SBC hydraulic unit (B, Figure 22) into SBC body mounting grommets.

26. Connect hydraulic lines and SBC suction hose (A, Figure 22) to SBC hydraulic unit (B); refer also to WIS: AR42.46-P-0010R steps 15 - 21.

Note:

Ensure new hose clamp (C) is installed.

27. Insert a cable tie through slot (arrows, Figure 19) in bracket, **do not** close cable tie.

Note:

Cable tie installation is shown on “bolt-on” type mounting bracket, cable tie installation for clamp-on type mounting bracket is similar.

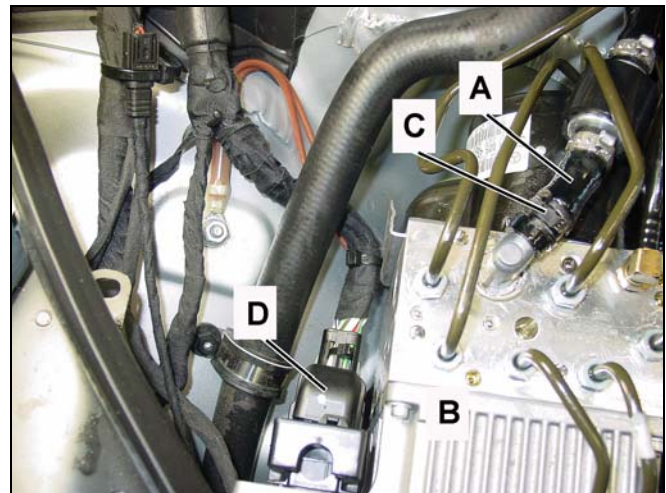

Figure 22

28. Connect the SBC wire harness connector (D, Figure 22) to the SBC hydraulic unit (B) and secure by engaging locking mechanism.

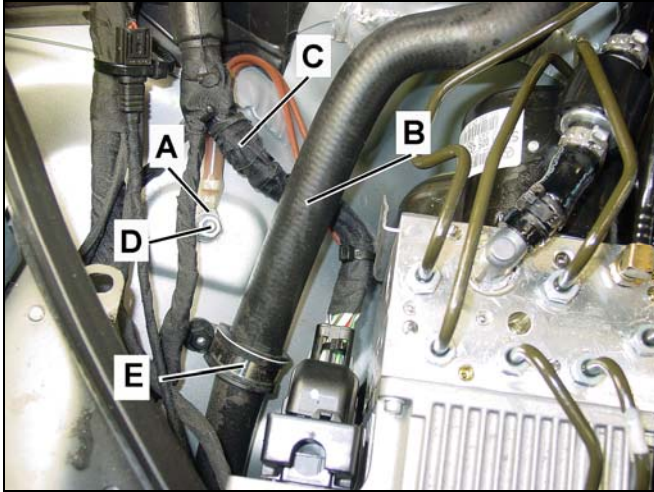

Figure 23

29. Attach hose mounting strap (E, Figure 23) to mounting stud, secure with nut
30. Position ground wiring harness parallel to the vehicle longitudinal axis (X-axis) on the body ground terminal. Torque the M6 nut to 10 Nm.

Note:

- Ring connector (A, Figure 23) **must** be positioned as shown to avoid contact with water hose (B) and chafing the wire harness (C).
- This ground terminal (D) is to be used **only** for mounting the SBC ground wire.

31. Complete the installation of the SBC hydraulic unit; check for leaks and bleed SBC system (refer to WIS: AR42.46-P-0010R), (Refer to SDS instructions).

Note (regarding above WIS instructions):

Disregard WIS notes regarding brake bleeder pressure. The maximum pressure for brake bleeder is **2.5** bar.

32. Connect SDS and check software release:

Note:

Ensure only the following versions of DAS are used:

- 11/2005 with SBC patch 479 installed on SDS
- Any DAS version after 11/2005

Navigate through the following menu items in DAS and follow on-screen instructions:

"Control units/Chassis/SBC - Sensotronic Brake Control/Control unit adaptations".

Note:

- Ensure to follow the on-screen instructions in DAS for connecting programming and terminal inspection tool to the SBC hydraulic unit.
- In the event of malfunctions during the SBC programming, a message will appear in the DAS display and a troubleshooting guide will be displayed.
- In the event DAS indicates that the SBC hydraulic unit requires replacement after inspecting SBC connector terminals, refer to WIS: AR42.46-P-0010R (for replacement instructions).

Note (regarding above WIS instructions):

Disregard WIS notes regarding brake bleeder pressure. The maximum pressure for brake bleeder is **2.5** bar.

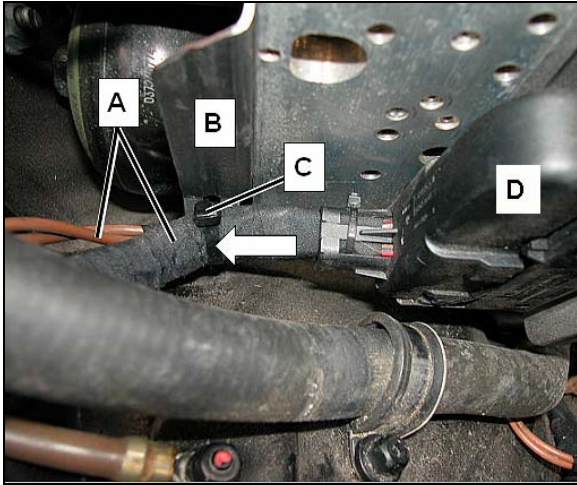

Figure 24

33. Secure ground wiring harness and SBC wiring harness (A, Figure 24) to SBC hydraulic unit bracket (B) with cable tie (arrow). Tighten cable tie (arrow) with Hellermann MK9 cable tie pliers (Special Tool: W 352 589 02 37 00) using **setting 3** on pliers.

Note:

- The cable tie buckle (C) must not touch the bracket (B).
- When mounting the wiring harness set (A) to the bracket (B), ensure that the wiring harness set (A) touches the bracket (B) and is mounted there tension free, ensuring the wiring harness set (A) does not pull on the SBC connector (D).
- After the SBC wire harness set (A) is secured, it must not be able to move in the longitudinal direction toward the bracket.
- Disregard WIS notes regarding torque settings on cable tie pliers. Use settings specified in this step.
- The ground wires (A) must be completely wrapped with fabric tape (as performed in step 21) in the area adjacent to the SBC hydraulic unit bracket (B) to ensure that the ground wires do not become chafed. Readjust tape as necessary to prevent chafing.

⚠ CAUTION!

Ensure harness is properly mounted to allow cable strain relief in area between cable tie and connector.

34. Proceed to **SUBJECT C – QUALITY ASSURANCE MEASURES**

C. QUALITY ASSURANCE MEASURES

CAUTION!

Check the quality measures outlined below after completing the service procedure.

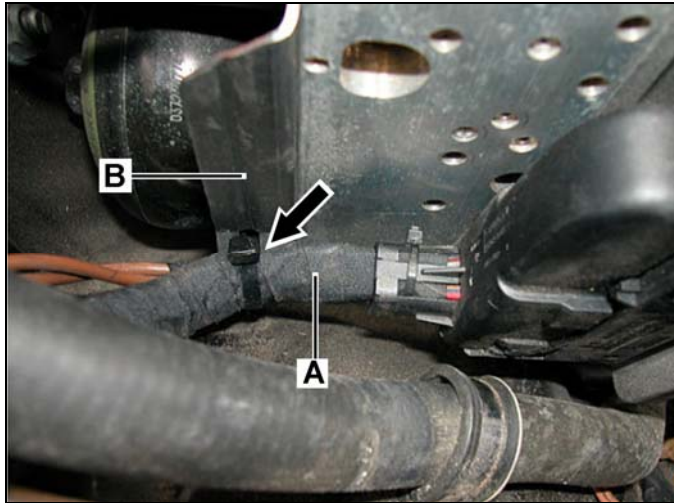

Figure 25

1. Quality measure 1:

- Ensure cable tie (arrow, Figure 25) was properly affixed using cable tie pliers (Hellermann MK9; special tool number W 352 589 02 37 00); use **setting 3 on cable tie pliers**, as shown in Figure 26.
- Ensure wiring harness (A, Figure 25) touches the bracket (B, Figure 25) and is mounted there free of tension.

CAUTION!

Ensure harness is properly mounted to allow cable strain relief in area between cable tie and connector.

2. Quality measure 2:

- Ensure wiring harness (A, Figure 27) and water hose (B, Figure 27) are not touching each other.

CAUTION!

Risk of chafing if wiring harness and water hose are touching.

3. Quality measure 3:

- Ensure tightening torque on ground terminal stud (arrow, Figure 27) is **between 7 and 10 Nm**.

CAUTION!

Risk of breaking ground terminal stud if torque of 10 Nm is exceeded.



Figure 26

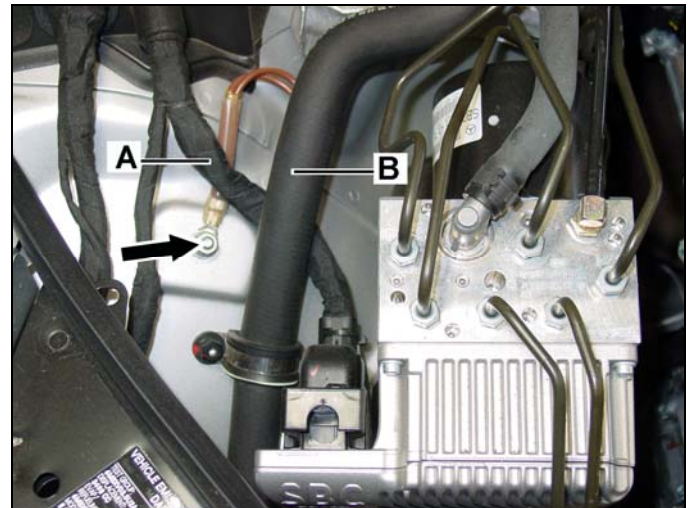

Figure 27

4. Quality measure 4:
- Ensure ground wires (A, Figure 28) are completely wrapped with fabric tape (as performed in step 21) in the area adjacent to the SBC hydraulic unit bracket (B) to ensure that the ground wires do not become chafed. Readjust tape as necessary to prevent chafing.

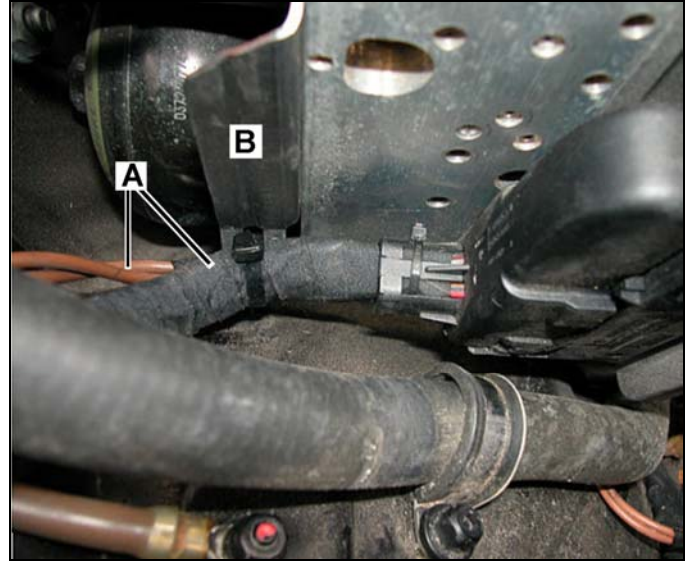
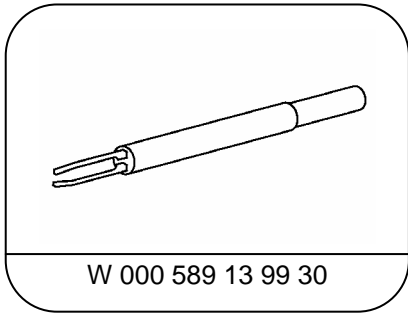

Figure 28

Special Tools



W 000 589 13 99 30

Blade

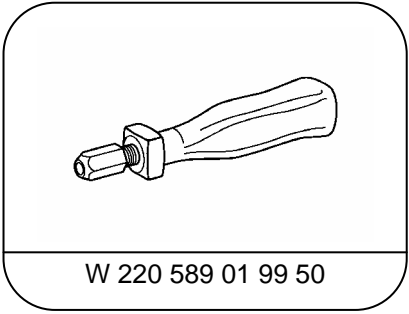

W 220 589 01 99 50

Handle



W 352 589 02 37 00

Cable tie pliers

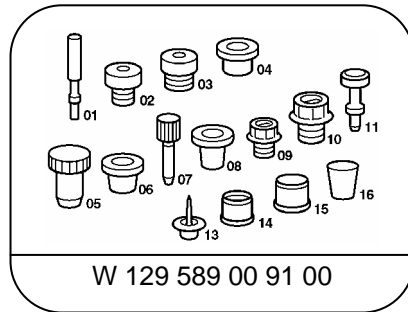

W 129 589 00 91 00

Stop Plug Kit

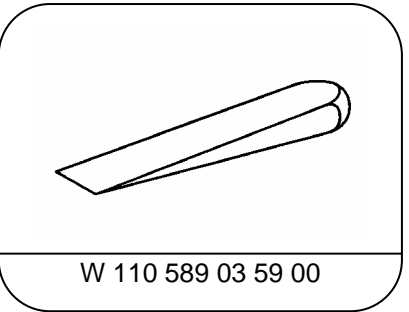

W 110 589 03 59 00

Plastic Wedge

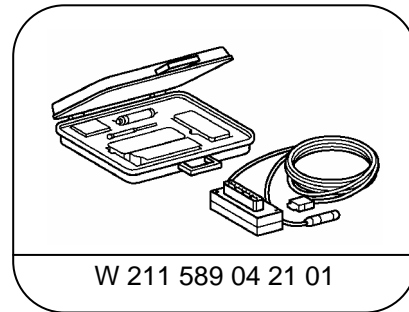

W 211 589 04 21 01

SBC Adapter 2005

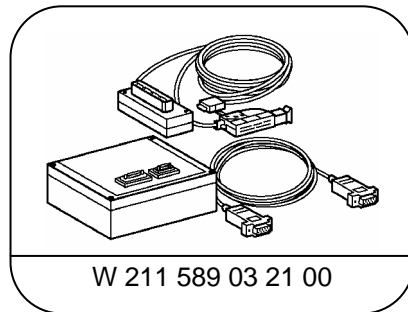

W 211 589 03 21 00

SBC Flash Adapter Set

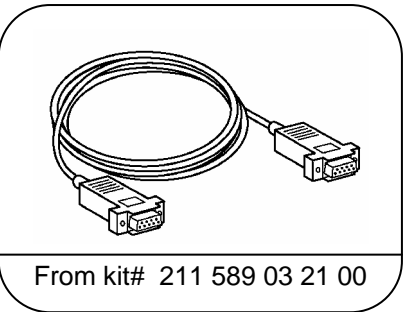

From kit# 211 589 03 21 00

9-Pin Serial Cable

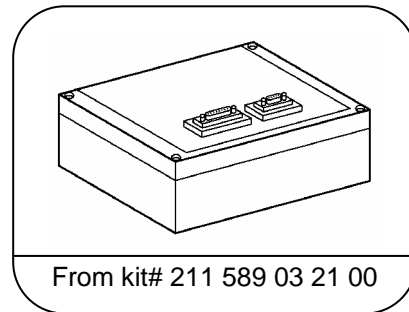

From kit# 211 589 03 21 00

Module Box

Special Tool Information

Special Tool Number	Group/ Category	Description	Dir Net
W 000 589 13 99 30 ¹⁾	00/ B	Blade; MCP/ JPT/ SPT	\$ 41.00
W 220 589 01 99 50 ¹⁾	00/ B	Blade Holder	\$ 9.00
W 352 589 02 37 00 ²⁾	54/ C	Tension Tool; Cable Tie	\$ 404.00
W 129 589 00 91 00 ³⁾	77/ K	Plug Set; Hydraulic	\$ 98.00
W 110 589 03 59 00 ⁴⁾	72/ K	Mounting Wedge	\$ 19.50
W 211 589 04 21 01 ^{5,7)}	54/ B	SBC Adapter 2005	\$ 15.00
W 211 589 03 21 00 ^{6,7)}	54/ B	SBC Flash Adapter Set	\$ 9.75
From kit W211 589 03 21 00 ⁸⁾	54/ B	9-pin Serial Cable	N/A
From kit W211 589 03 21 00 ⁸⁾	54/ B	Module Box	N/A

Note:

¹⁾ Special Tool W 000 589 13 99 30 is interchangeable with W 220 589 01 99 61. Special Tool W 000 589 13 99 30 is the latest replacement for an existing Special Tool W 220 589 01 99 61, released and automatically delivered to all Mercedes-Benz dealers in the Wiring Harness Repair Kit: Special Tool W 220 589 01 99 00 (and later as W 220 589 02 99 00).

²⁾ Special Tool W 352 589 02 37 00 will be released and automatically delivered 1 per each Mercedes-Benz dealer.

³⁾ This required Special Tool should already be in stock at each Mercedes-Benz dealer location.

⁴⁾ This is a sample Special Tool number provided for your reference.

⁵⁾ Special Tool kit W211 589 04 21 01 will be released and automatically delivered to each Mercedes-Benz dealer.

⁶⁾ Use only 9-pin serial cable (W 211 589 03 21 02) and module box (W 211 589 03 21 03) from Special Tool kit W 211 589 03 21 00. Do not use 47-pin adapter cable (W 211 589 03 31 01).

⁷⁾ This Special Tool is not available for dealer order. Because of limited quantities, MBUSA will allocate initial distribution and replacement units as needed on a case-by-case basis. To inquire, please call 201-573-2741.

⁸⁾ These Special Tools were part of the SBC Flash Adapter Set (W 211 589 03 21 00); they cannot be ordered individually.

Required Equipment Information

Part Number	Description	MFR.
275-ST-BBE-2.5 ¹⁾	Brake Bleeder, Stierius	Bodo Stier GmbH (via Power Probe)

Note:

Brake bleeder is available via the MBUSA Standard Service Equipment Program (SSEP) at 1-888-458-4040.

¹⁾ This item was released and automatically delivered to all Mercedes-Benz dealers who did not procure the unit via the MBUSA Standard Service Equipment Program. As a Special Tool, this unit is identified with, and can be ordered using, the MBUSA Special Tool Number: W 900 589 01 71 00.

Primary Parts Information

Qty.	Part Name	Part Number	Estimated Replacement Rate
1	Ground wiring harness	A 211 440 35 08	100%
3	Cable tie	A 001 997 83 90	100%
1	Bracket	A 211 545 00 47 28	100%
1	Guide bracket	A 211 546 74 43	100%
1	Screw (self-tapping)	A 000 990 37 11	100%
1	Interwoven adhesive tape ¹⁾	A 006 989 84 85 10	100%

NOTE:

THE FOLLOWING SECONDARY PART(S) IS/ARE NOT TO BE ORDERED IN EQUAL QUANTITIES AS THE PRIMARY PART(S). THEREFORE DO NOT PACKAGE OR KIT CAMPAIGN PARTS TOGETHER SINCE NOT ALL VEHICLES WILL REQUIRE THESE PARTS.

Secondary Parts Information

Qty.	Part Name	Part Number	Estimated Replacement Rate
1	Suction hose	A 211 420 90 26 05	60%
1	Suction hose (with double pulsation damper)	A 211 420 88 26 05	5%
2	Hose clamps	A 005 997 19 90	65%
1	SBC hydraulic unit	A 005 431 71 12 05 ²⁾	65%
		A 005 431 79 12 05 ³⁾	
2.25 l	Brake fluid ⁴⁾	A 000 989 08 07 01	65%
1	Bracket (clamp-on)	A 211 545 04 47 05	<1%

Note:

¹⁾ Submit as local purchase "TPE00013" quantity of 1 (handling is included).

²⁾ The following vehicles require the SBC Hydraulic Unit with part number A 005 431 71 12 05 (32 MHz):

- Vehicles with code 802
- Vehicles with code 803 without code 053

³⁾ The following vehicles require the SBC Hydraulic Unit with part number A 005 431 79 12 05 (40 MHz):

- Vehicles with code 803 and code 053
- Vehicles with code 804

⁴⁾ Submit as local purchase "BRAKEFL01653" quantity of 1 (handling is included).

Note:

- Please be aware that only the part number(s) referenced in the Campaign Bulletin is/are approved for use to repair the vehicle. Repairs performed using any other part(s) will not have been performed in accordance with the campaign. Accordingly, warranty claims submitted with reference to an improper part number(s) will be denied.
- The following allowable labor operation should be used when submitting a warranty claim for this repair:

Warranty Information (MODEL 211)**Note:**

In the event that SBC hydraulic unit replacement becomes necessary based on the serial number range check performed in Subject A of the campaign procedure, use Repair 3 or 4 to submit a claim. If the SBC hydraulic unit needs to be replaced for reasons other than the serial number, complete and close the Recall Campaign and refer to Netstar message titled "Extended Limited Warranty on SBC Hydraulic Units" dated May 5, 2006.

Repair 1 (Check hydraulic unit, mount ground wire and bracket)

Operation: Diagnosis assistance system (DAS), connect & disconnect (02-4762)
SBC hydraulic unit – number range, check (02-4821)
Ground wire & bracket-SBC wiring harness, install (02-4846)

Damage Code	Operation Number	Labor Time (hrs.)	Model Indicator(s)
43 911 01 7	02-4762	0.2 hrs.	T1, T2, T3, T4, T5, T6, U1, U3, U4
	02-4821	0.1 hrs.	T1, T2, T3, T4, T5, T6, U1, U3, U4
	02-4846	0.4 hrs.	T1, T2, T3, T4, T5, T6, U1, U3, U4

Repair 2 (Check hydraulic unit, mount ground wire and bracket, perform software update)

Operation: Diagnosis assistance system (DAS), connect & disconnect (02-4762)
SBC hydraulic unit – number range, check (02-4821)
Ground wire & bracket-SBC wiring harness, install (02-4846)
Software - (DAS connected), install (02-4886)

Damage Code	Operation Number	Labor Time (hrs.)	Model Indicator(s)
43 911 01 7	02-4762	0.2 hrs.	T1, T2, T3, T4, T5, T6, U1, U3, U4
	02-4821	0.1 hrs.	T1, T2, T3, T4, T5, T6, U1, U3, U4
	02-4846	0.4 hrs.	T1, T2, T3, T4, T5, T6, U1, U3, U4
	02-4886	0.4 hrs.	T1, T2, T3, T4, T5, T6, U1, U3, U4

Repair 3 (Check, replace hydraulic unit, mount ground wire and bracket, replace suction hose)

Operation: Diagnosis assistance system (DAS), connect & disconnect (02-4762)
SBC hydraulic unit – number range, check (02-4821)
SBC hydraulic unit (DAS connected), replace (02-4822)
(Note: 02-4822 Includes suction hose replacement)
Ground wire&bracket-SBC wire harn.(hyd.unit rem.),mount (02-4831)

Damage Code	Operation Number	Labor Time (hrs.)	Model Indicator(s)
43 911 01 7	02-4762	0.2 hrs.	T1, T2, T3, T4, T5, T6, U1, U3, U4
	02-4821	0.1 hrs.	T1, T2, T3, T4, T5, T6, U1, U3, U4
	02-4822	2.8 hrs.	T1, T2, T4, T5, T6, U1, U3, U4
	02-4822	2.9 hrs.	T3
	02-4831	0.3 hrs.	T1, T2, T3, T4, T5, T6, U1, U3, U4

Repair 4 (Check, replace hydraulic unit, mount ground wire and bracket, replace suction hose, perform software update)

Operation: Diagnosis assistance system (DAS), connect & disconnect (02-4762)
 SBC hydraulic unit – number range, check (02-4821)
 SBC hydraulic unit (DAS connected), replace (02-4822)
 (Note: 02-4822 Includes suction hose replacement)
 Ground wire&bracket-SBC wire harn.(hyd.unit rem.),mount (02-4831)
 Software - (DAS connected), install (02-4886)

Damage Code	Operation Number	Labor Time (hrs.)	Model Indicator(s)
43 911 01 7	02-4762	0.2 hrs.	T1, T2, T3, T4, T5, T6, U1, U3, U4
	02-4821	0.1 hrs.	T1, T2, T3, T4, T5, T6, U1, U3, U4
	02-4822	2.8 hrs.	T1, T2, T4, T5, T6, U1, U3, U4
	02-4822	2.9 hrs.	T3
	02-4831	0.3 hrs.	T1, T2, T3, T4, T5, T6, U1, U3, U4
	02-4886	0.4 hrs.	T1, T2, T3, T4, T5, T6, U1, U3, U4

NOTE REGARDING CUSTOMER REIMBURSEMENT

Reimbursement to customers for repairs performed prior to this recall:

If the customer already paid to have this recall campaign condition repaired and provides adequate documentation to support their claim of a non-warranty repair of this item, they may be eligible to receive reimbursement.

Requests for reimbursement may include parts, labor, fees and taxes.

Reimbursement is limited to the amount the repair of the SBC hydraulic Unit, suction hose, ground wire and bracket, and related parts associated to these replacements (ex. screws, clamps, brake fluid) would have cost if completed by an authorized Mercedes-Benz dealer under this campaign.

Submit a warranty claim, utilizing Damage Code 43911018 as a sublet, utilizing the sublet code of "SUB." Sublet repairs require dealer text as stated in the Warranty Policies and Procedures Manual. Repair date should be the date that the customer paid for the repair.

Note:

Please note the claim submitted for customer reimbursement will **not** close the campaign (if still open).If the customer is still in possession of the vehicle with an open campaign, please arrange to close the campaign in the usual manner as described in this bulletin.

II MODEL 230 INSPECT SBC HYDRAULIC UNIT, REPLACE AS DIRECTED

Procedure

A. INSPECTION OF SBC HYDRAULIC UNIT

1. Check if SBC hydraulic unit part number (A, Figure 1) is listed in the table below:
 - If the part number (A) **is** listed, proceed to step 2.
 - If the part number (A) is **not** listed, proceed to step 3.

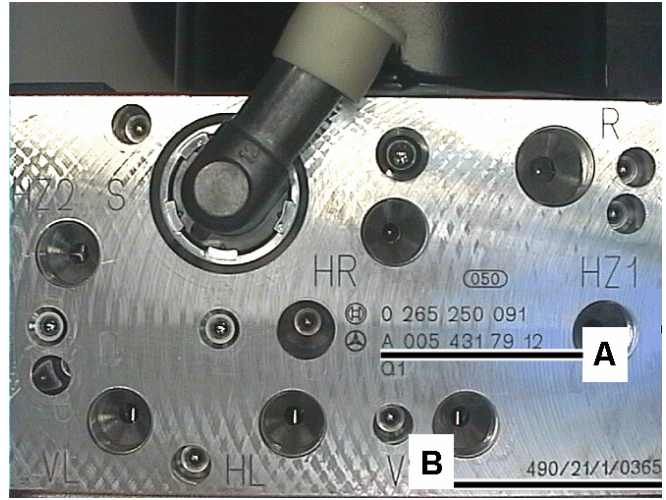

Figure 1

2. Check (refer to table below) if the production number (B, Figure 1) is within the listed production number range for the relevant part number (A):
 - If the production number (B) is **not** within the production number range, proceed to step 3.
 - If the production number (B) **is** within the production number range compared to the relevant part number; proceed to Subject **B**, Replacement of SBC Hydraulic unit.
(E.g., for SBC hydraulic unit part number: A 005 431 68 12. The production number 392/08/1/0500 is **not** within the number range – proceed to step 3. The production number 392/11/1/0700 **is** within the number range – proceed to Subject B, Replacement of SBC Hydraulic unit).
3. Do **not** replace SBC Hydraulic unit. Only perform the replacement of the suction hose, and the installation of ground wires and bracket to the SBC wiring harness. Proceed to Subject B and perform the following steps **only**: 1 - 6, 8 - 21, 24 - 28, 30 - 33.

Note:

Perform step 21 (“Installing bolt-on mounting bracket”) only if SBC hydraulic unit does not have connector mounting bracket bores machined into side of SBC unit.

Table

Part number	Production number	
	From	To
A 005 431 68 12	392/09/1/0496	392/12/1/0641
A 005 431 05 12	391/24/1/0680	481/08/1/0290
A 004 431 82 12	392/10/1/0244	392/18/1/1198
A 005 431 06 12	392/01/1/1152	481/08/1/0165
A 004 431 83 12	392/08/1/0525	392/08/1/0534

Note:

When reading the production number (B, Figure 1) on the SBC hydraulic pump, disregard the slashes.

The production number should be read as a whole number:

e.g., 392/08/1/0534 = 3,920,810,534

B. REPLACEMENT OF SBC HYDRAULIC UNIT (MODEL 230)

WARNING!

Risk of injury caused by body parts being pinched or crushed. Risk of injury to skin and eyes caused by brake fluid spraying out at high pressure when working on the SBC brake system

Risk of poisoning from swallowing brake fluid.

Pour brake fluid only into suitable and appropriately marked containers. Wear protective clothing and eye protection when handling brake fluid.

1. Deactivate SBC system using Star Diagnosis (DAS).
2. Remove intake duct (arrow, Figure 2) on right side of engine.

Note:

For models with 12 cylinder engines also remove right air cleaner, refer to WIS:

AR09.10-P-1150LA.



Figure 2

3. Disconnect SBC hydraulic unit harness connector (arrow, Figure 2a) from SBC hydraulic unit (A) and remove cable tie (B, Figure 3).

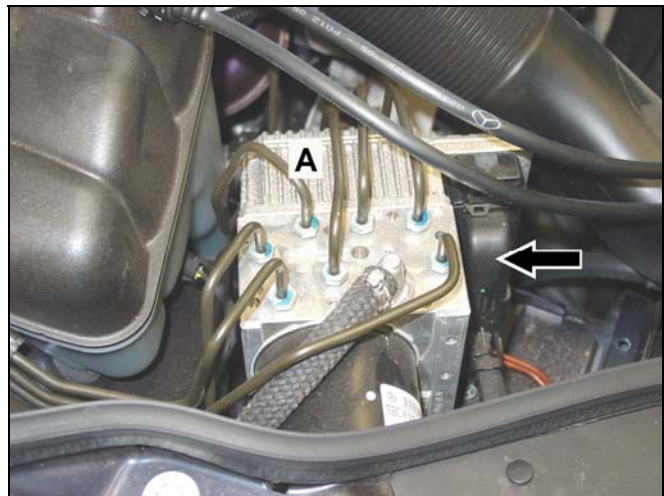

Figure 2a

4. Detach the SBC hydraulic unit ground wire harness (arrow, Figure 3) at ground terminal stud (A).
5. Position SBC harness connector (arrow, Figure 2a) away from SBC hydraulic lines to prevent brake fluid from dripping on SBC harness connector and SBC wiring harness.

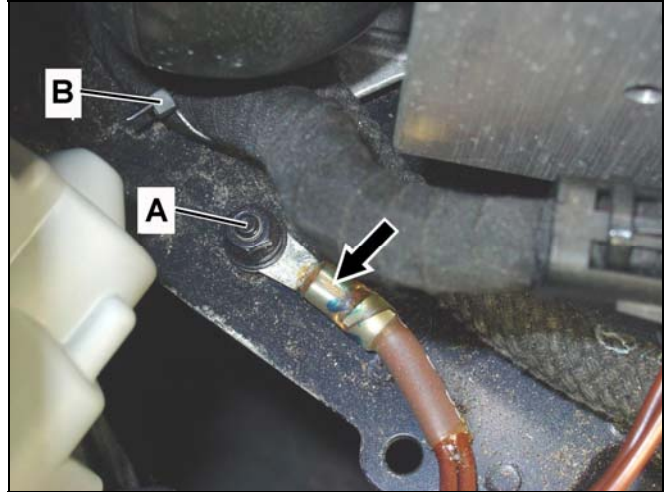

Figure 3

6. Remove omega (arrows, Figure 4) hose clips from SBC hydraulic unit bracket (A).
7. Remove SBC hydraulic unit refer to WIS: AR42.46-P-0010R steps 1 - 3, 5 - 14.

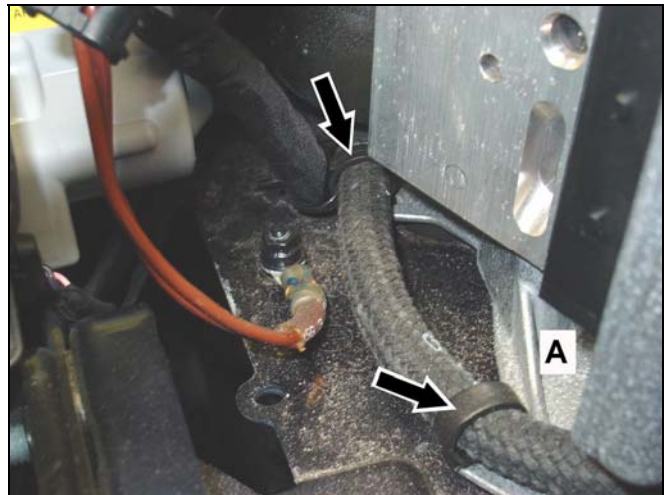

Figure 4



Figure 5



Figure 6

8. Inspect which version of the suction hose is installed on the SBC hydraulic pump:
- If new version (rubber) hose (arrow, Figure 5) is installed, skip ahead to step 10.
 - If previous version (braided) hose (arrow, Figure 6) is installed, proceed to step 9 to replace the suction hose.

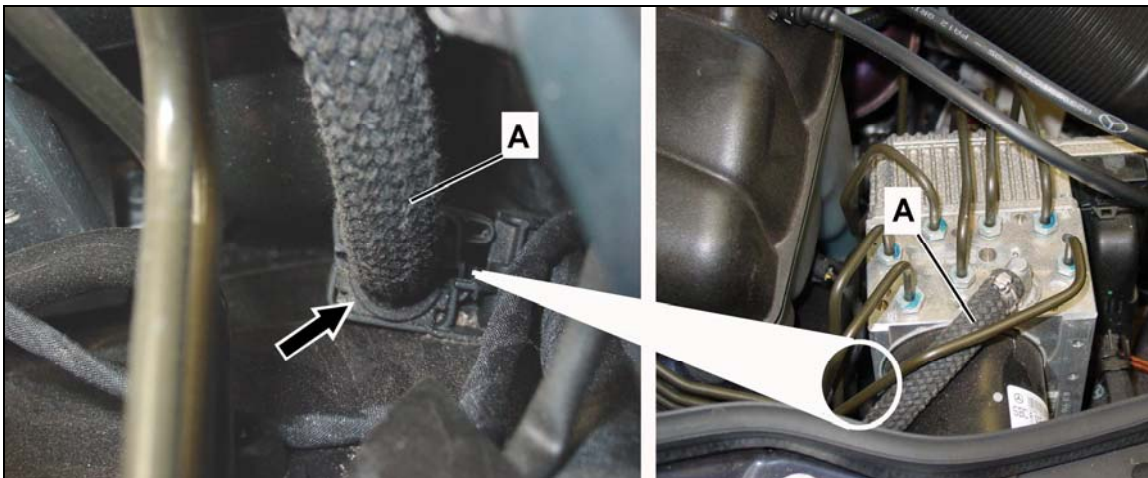

Figure 7

9. Replace suction hose (A, Figure 7):
- Open the suction hose mounting clip (arrow) and remove suction hose (A) from bracket.
 - Remove mounting clip (arrow) from threaded stud and discard.

- Remove hose clamp (A, Figure 8) then remove suction hose (arrow) from suction line (B) using a plastic wedge (Example: Special Tool: W110 589 03 59 00).

⚠ CAUTION!

- Do not use sharp-edged tools (e.g., screwdriver) to remove suction hose (arrows, Figure 8) from suction line (B), as this may cause damage to the SBC brake system.

Note:

- When removing suction hose (arrow), do not bend suction line (B).
- To prevent brake fluid from running out and to prevent contamination in the brake system, the suction hose (arrows, Figure 8) and line (B) are to be plugged using suitable plugs from the stop plug kit (Special Tool: W129 589 00 91 00).
- Discard old suction hose (arrow) and clamp (A) after removal.

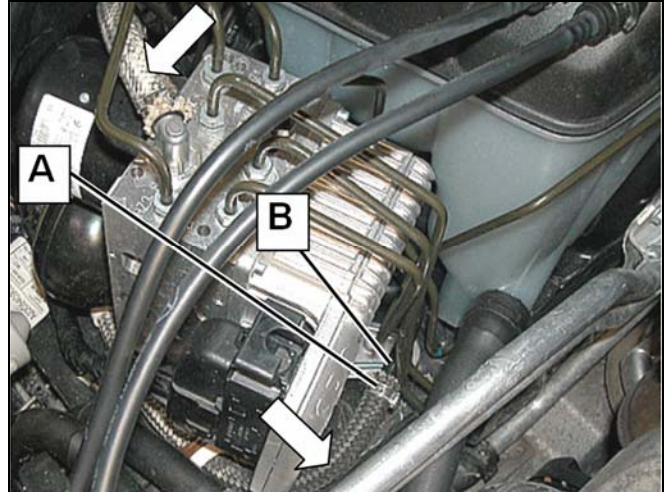

Figure 8 (Shown with SBC hydraulic unit installed)

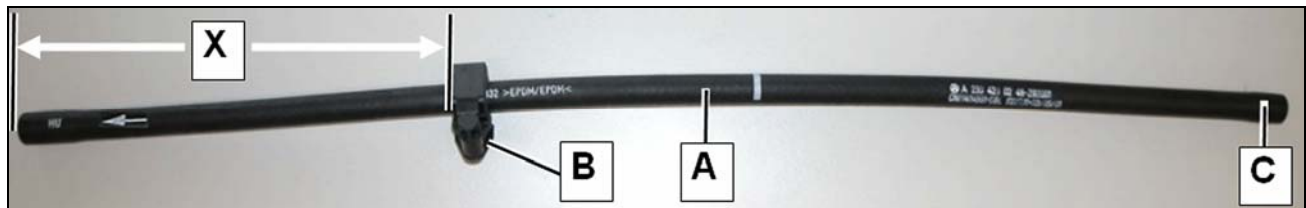

Figure 9 Dimension X = 20 cm

- Verify that the dimension X (Figure 9) on the **new** SBC suction hose (A) equals 20 cm. Adjust (if necessary) by repositioning the mounting clip (B) on the SBC suction hose (A).
- Place new hose clamp onto unmarked side of suction hose (C, Figure 9).
- Connect the unmarked end of the suction hose (C, Figure 9) onto the suction line (A, Figure 10) and secure hose with a **new** hose clamp (arrow, Figure 10).

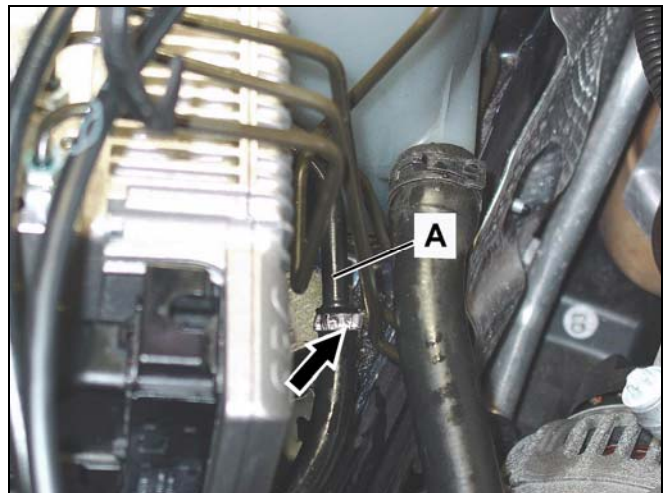

Figure 10

- Install the new SBC suction hose mounting clip (arrow, Figure 11) onto the mounting stud.

Note:

To gain better access to mounting clip (during installation); remove the plastic cover over the right head lamp; then tap the clip into place using a socket extension and plastic mallet.



Figure 11

10. Remove cable tie (left arrow, Figure 12) securing ground wires (A) to SBC connector housing (B).
11. Remove cable tie (right arrow, Figure 12) securing SBC wire harness (C) to SBC connector housing (B).

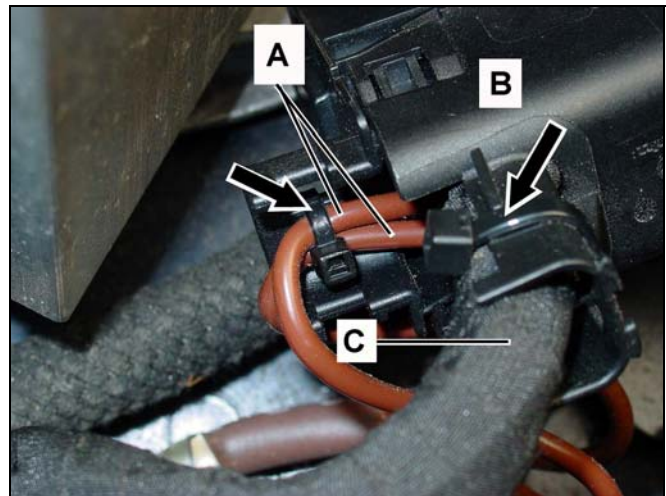

Figure 12

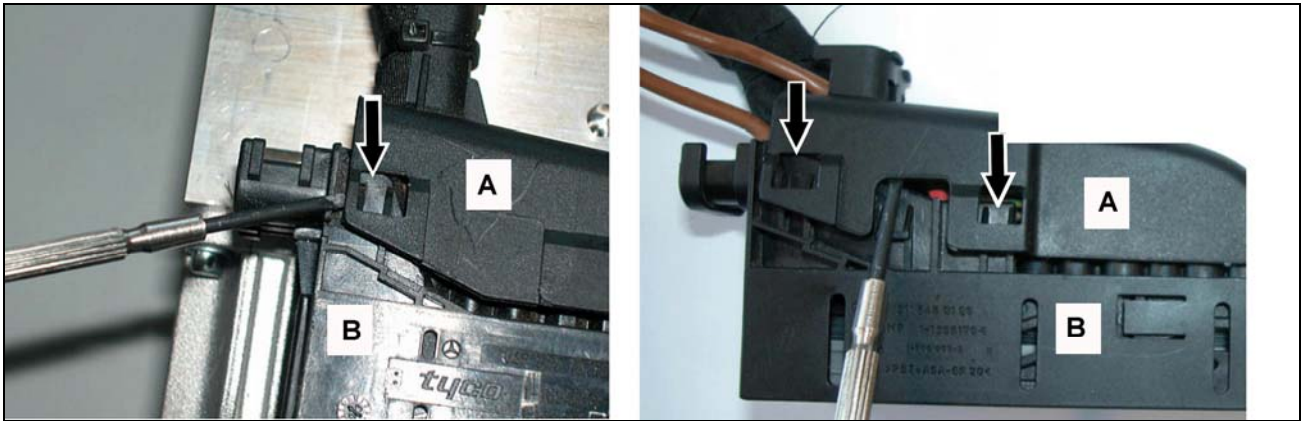

Figure 13

12. Remove SBC connector housing cover (A, Figure 13):

- Using a small screw driver, carefully pry cover (A) away from locking lugs (arrows) until cover (A) disengages.
- Repeat the process on opposite side.
- Remove the cover (A) from the housing (B).

Note:

There are two different versions of the SBC wiring harness connector (Figures 14a, b) installed in vehicles involved with this campaign.

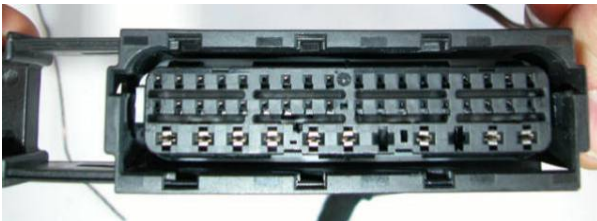

Figure 14a (Connector Type A)



Figure 14b (Connector Type B)

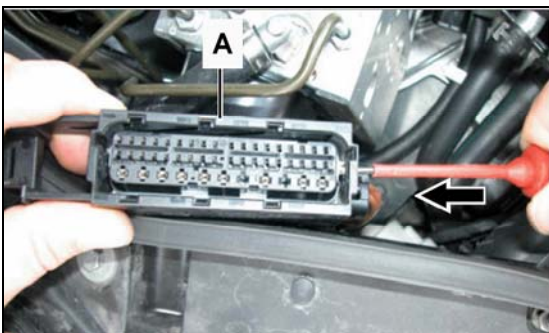

Figure 15a (Connector Type A)

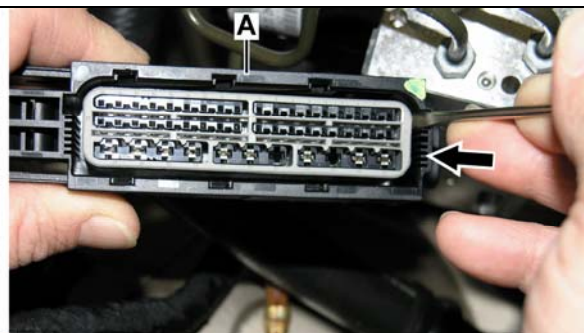

Figure 15b (Connector Type B)

13. Open the (gray) secondary lock in the SBC connector housing (A, Figure 15) by sliding the lock in the direction indicated by the arrows (Figure 15) using a small screwdriver.

14. Remove SBC ground wires (arrows, Figure 17) from SBC harness connector (A):
 - Unpin SBC ground wire connectors (position 37 and 44) using cable release (Special Tools: W 000 589 13 99 30 and W 220 589 01 99 50) and remove ground wires (arrows) from SBC connector housing (A).
 - Discard old ground wire harness, it is no longer needed.
15. Insert the new ground wire harness (arrows Figure 17) into the SBC connector housing (A):
 - Insert **longer** ground wire into position 44.
 - Insert **shorter** ground wire into position 37.

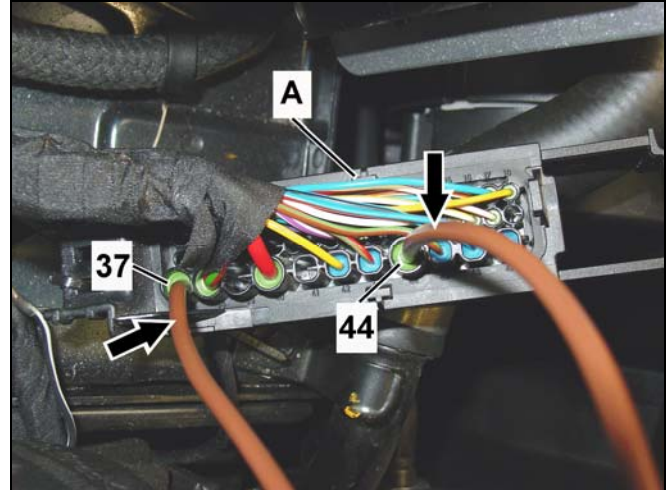

Figure 17

Note:

Ensure ground wire connectors are **properly** locked into place.

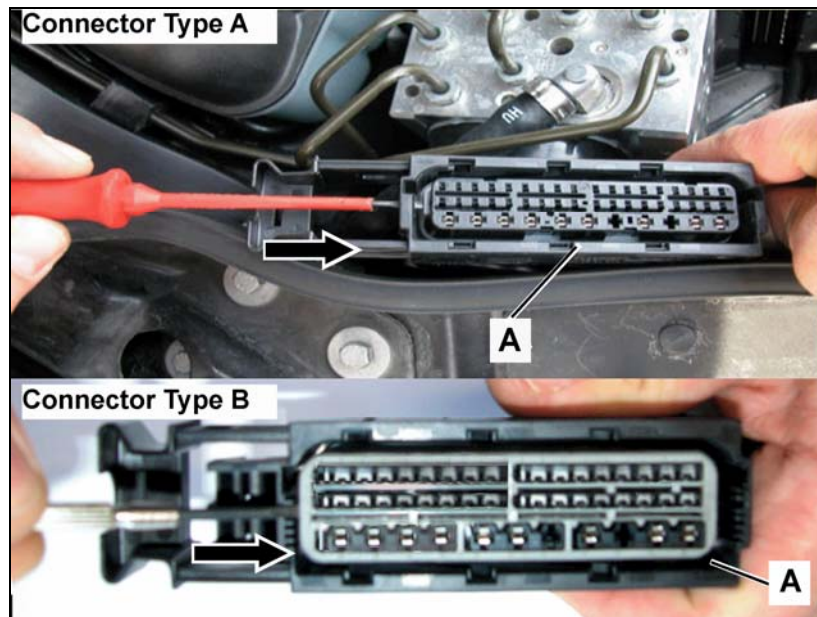

Figure 18

16. Close the (gray) secondary lock of the SBC connector housing (A, Figure 18) by sliding the lock in the direction indicated by the arrows (Figure 18) using a small screwdriver until it locks into place.
17. Reinstall connector cover (A, Figure 13) in reverse order.

18. Secure SBC wiring harness (A, Figure 19) (**excluding** ground wires) to the SBC connector cover receptacle (arrow) using a new cable tie (B).

Note:

- Ensure that the SBC wiring harness (A) is properly routed so that it is free of tension in the SBC connector housing.
- The cable tie “buckle” (D) **must be located at the side of the connector cover receptacle (arrow) as depicted.**

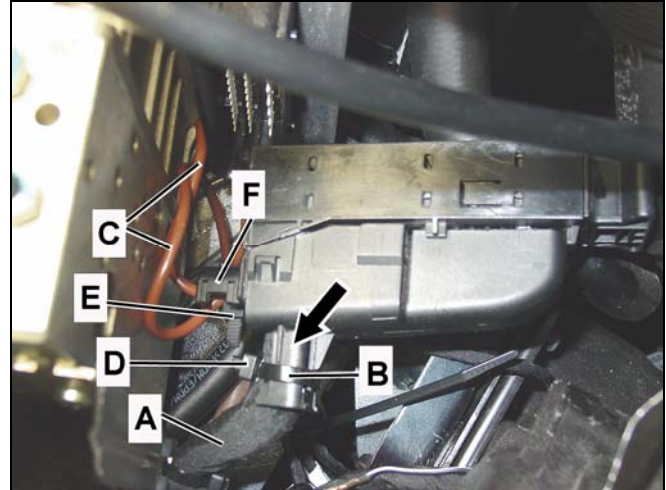

Figure 19

19. Secure ground wiring harness (C) to the SBC connector housing receptacle (F) using a new cable tie (E).

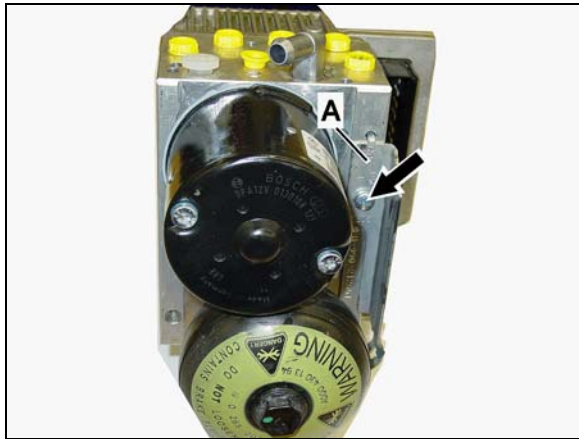

Figure 20

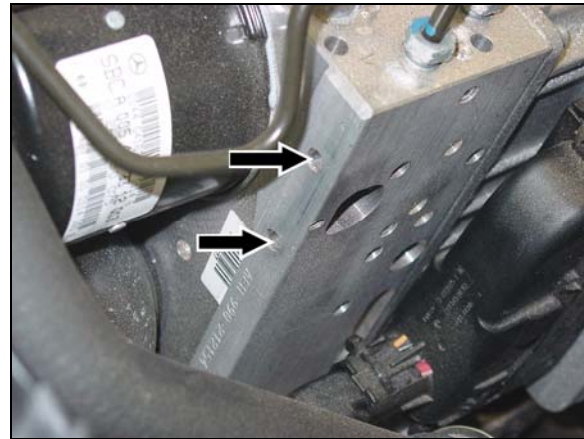

Figure 21

20. Attach SBC harness mounting bracket to the SBC hydraulic unit:

- Using hand tools, tap threads into SBC hydraulic unit bores (arrows, Figure 21) by running self tapping screw (arrow, Figure 20) into lower bore **without** mounting bracket positioned on SBC unit.

Note:

- In order to avoid breaking the self-tapping screw (arrow) during installation, the screw (arrow) must be **positioned absolutely straight**
- Do not use power tools to install self tapping screw.
- In the event self tapping screw (arrow, Figure 20) is broken during installation of bracket (A) perform step 21 then continue with campaign (installation of bracket due to breakage of mounting screw will **not** be covered under warranty).
- Remove self tapping screw (arrow).
- Position bracket (A) on SBC hydraulic unit, reinstall self tapping screw (arrow) and **torque to 7 Nm**

21. Install clamp-on mounting bracket (Figure 22) if necessary due to broken self-tapping screw:

Note:

Ensure sheathing (arrow) on mounting bracket clamp is positioned as shown in Figure 22.

- Position mounting bracket (B) onto SBC hydraulic unit (A) as shown in Figure 23.



Figure 22

Note:

- Ensure mounting bracket (B, Figure 23) is flush with SBC hydraulic unit (A).
- Torque mounting clamp screw (C) to 5 Nm while pressing bracket (B) onto SBC unit (A) (Proceed to step 24).

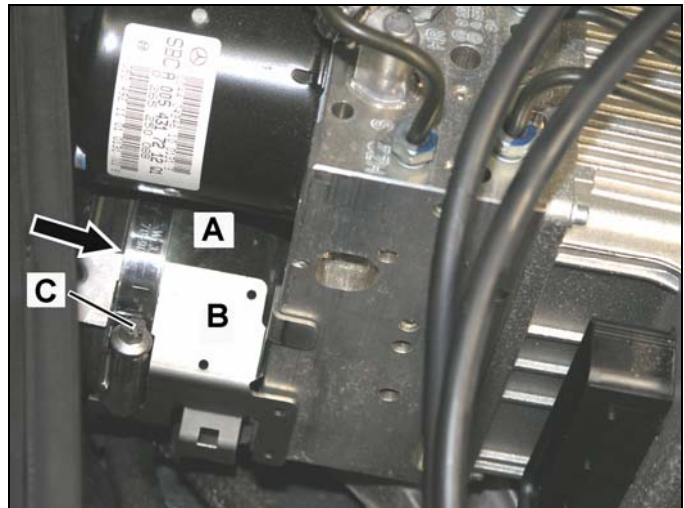

Figure 23

22. Install new SBC hydraulic unit into SBC body mounting grommets.

23. Connect hydraulic lines to SBC unit; refer also to WIS: AR42.46-P-0010R steps 15 - 21.

24. Connect SBC suction hose (A, Figure 24) to SBC hydraulic unit fitting (B); refer also to WIS: AR42.46-P-0010R steps 15 - 21.

Note:

Ensure new hose clamp (arrow) is installed.

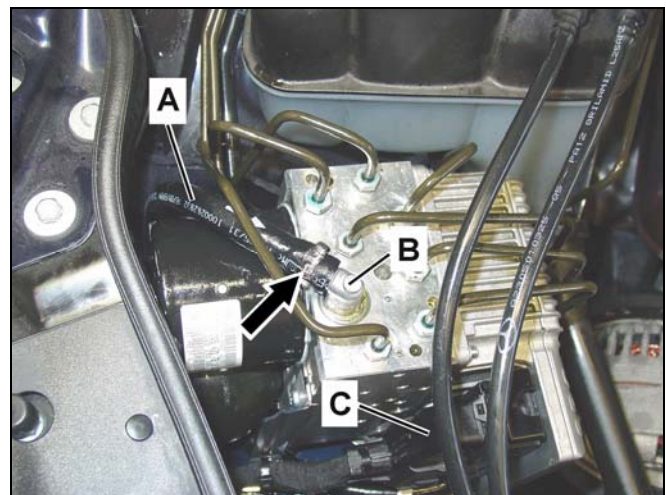

Figure 24

25. Secure new SBC suction hose (A, Figure 25) to SBC hydraulic unit mounting bracket (B) using **new** (“omega” type) mounting clips (arrows).

26. Insert a cable tie through slots (C, Figure 25) in bracket (D), **do not** close cable tie

Note:

Cable tie installation is shown on “bolt-on” type mounting bracket, cable tie installation for clamp-on type mounting bracket is similar.

27. Connect SBC harness connector (A, Figure 27) to SBC hydraulic unit and secure by engaging locking mechanism.

28. Attach the ground wire harness ring connector (A, Figure 26) to the body ground terminal (B) with M6 nut. Torque the M6 nut to 10 Nm.

Note:

- The ground wire harness (arrow) must be routed under the SBC suction hose (C). The ring connector (A) **must** be positioned as shown in Figure 26.
- This ground terminal (B) is to be used **only** for mounting the SBC ground wire harness (arrow).

29. Complete the installation of the SBC hydraulic unit.

30. Check for leaks and bleed SBC system (refer to WIS: AR42.46-P-0010R), (Refer to SDS instructions).

Note (regarding above WIS instructions):

Disregard WIS notes regarding brake bleeder pressure. The maximum pressure for brake bleeder is **2.5** bar.

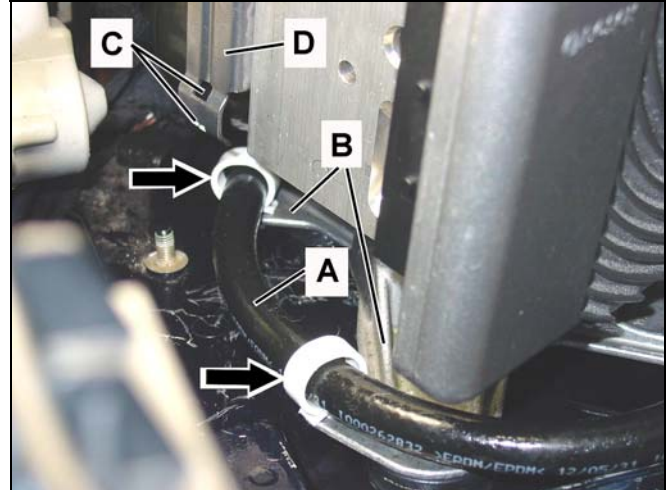

Figure 25

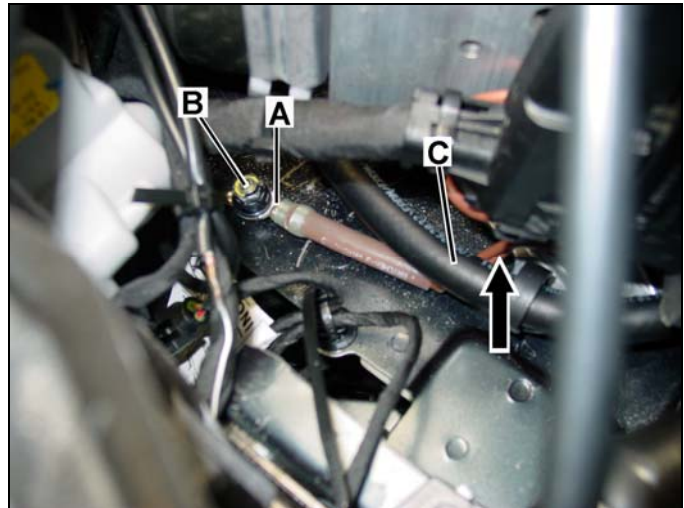

Figure 26

31. Connect SDS and check software release:

Note:

Ensure only the following versions of DAS are used:

- 11/2005 with SBC patch 479 installed on SDS
- Any DAS version after 11/2005

Navigate through the following menu items in DAS and follow on-screen instructions: "Control units/Chassis/SBC - Sensotronic Brake Control/Control unit adaptations".

Note:

- Ensure to follow the on-screen instructions in DAS for connecting programming and terminal inspection tool to the SBC hydraulic unit.
- In the event of malfunctions during the SBC programming, a message will appear in the DAS display and a troubleshooting guide will be displayed.
- In the event DAS indicates that the SBC hydraulic unit requires replacement after inspecting SBC connector terminals, refer to WIS: AR42.46-P-0010R (for replacement instructions).

Note (regarding above WIS instructions):

Disregard WIS notes regarding brake bleeder pressure. The maximum pressure for brake bleeder is **2.5 bar**.

32. Secure SBC wiring harness (B, Figure 27) to SBC hydraulic unit bracket (C) with cable tie (arrow). Tighten cable tie (arrow) using Hellermann MK9 cable tie pliers (Special Tool W 352 589 02 37 00); use **setting 3** on cable tie pliers.

Note

- The cable tie buckle (D) must not touch the bracket (C).
- When attaching SBC wire harness (B) to the bracket (C), ensure that the wire harness (B) touches the bracket (C) and is mounted there tension free.
- After the SBC wire harness (B) is secured, it must not be able to move in the longitudinal direction toward the bracket.

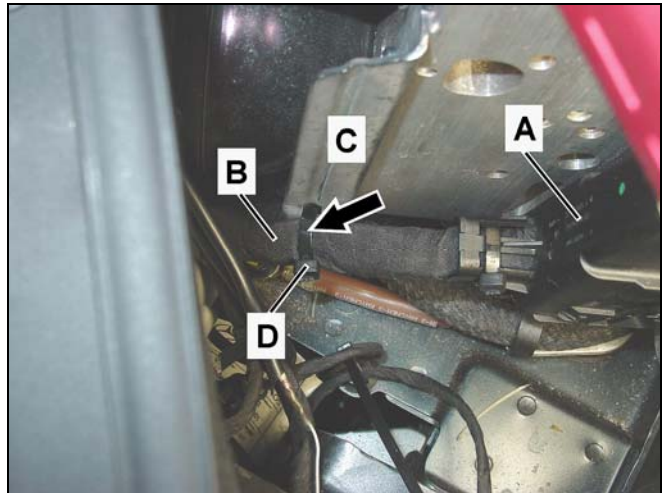

Figure 27

⚠ CAUTION!

Ensure harness is properly mounted to allow cable strain relief in area between cable tie and connector.

33. Proceed to **SUBJECT C – QUALITY ASSURANCE MEASURES**.

C. QUALITY ASSURANCE MEASURES

CAUTION!

Check the quality measures outlined below after completing the service procedure.



Figure 28



Figure 29

1. Quality measure 1:

- Ensure cable tie (arrow, Figure 28) was properly affixed using cable tie pliers (Hellermann MK9; special tool number W 352 589 02 37 00); use **setting 3 on cable tie pliers**, as shown in Figure 29.
- Ensure wiring harness (A, Figure 30) touches the bracket (C, Figure 28) and is mounted there tension free.

CAUTION!

Ensure harness is properly mounted to allow cable strain relief in area between cable tie and connector.

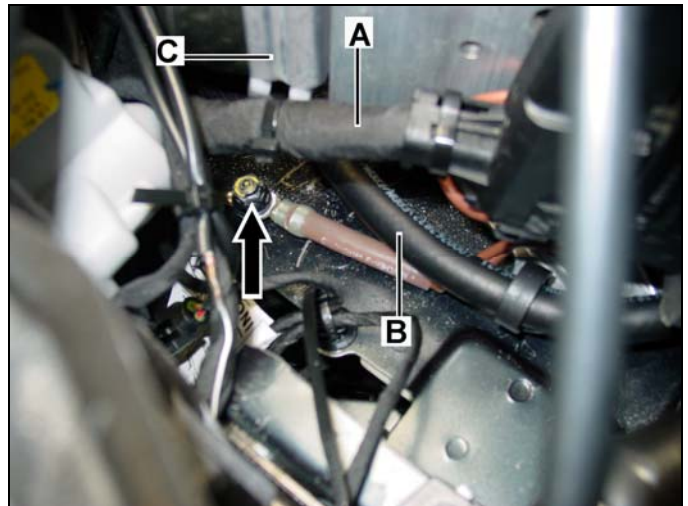

Figure 30

2. Quality measure 2:

- Ensure wiring harness (A, Figure 30) and water hose (B, Figure 30) are not touching each other.

CAUTION!

Risk of chafing if wiring harness and water hose are touching.

3. Quality measure 3:

- Ensure tightening torque on ground terminal stud (arrow, Figure 30) is **between 7 and 10 Nm**.

CAUTION!

Risk of breaking ground terminal stud if torque of 10 Nm is exceeded.

Special Tools

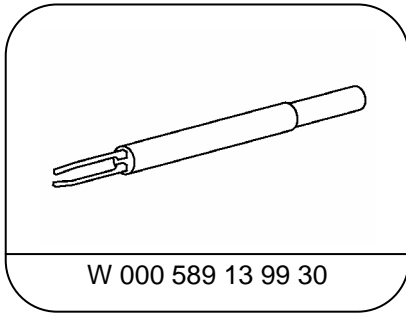

Blade

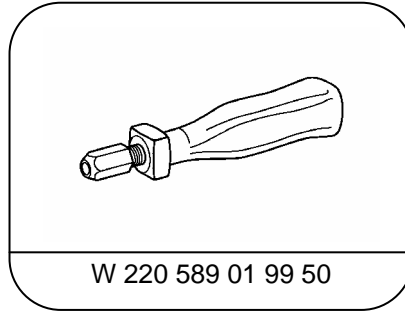

Handle



Cable tie pliers

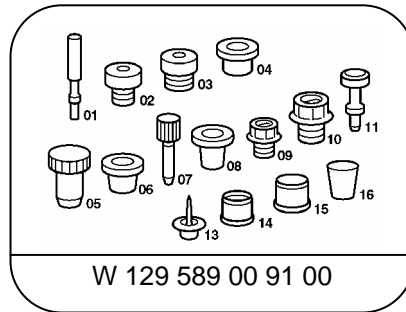

Stop Plug Kit

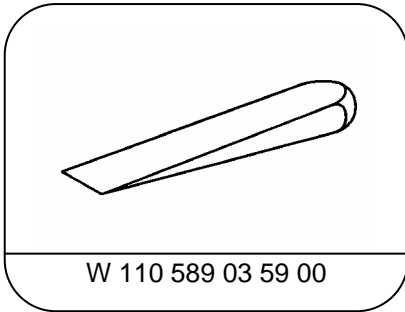

Plastic Wedge

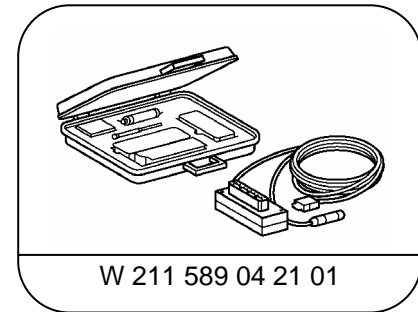

SBC Adapter 2005

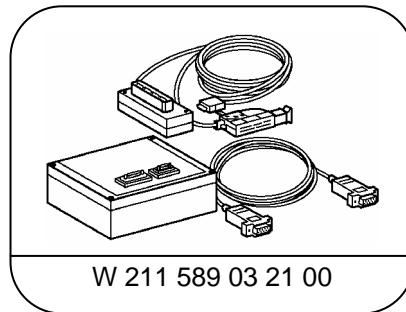

SBC Flash Adapter Set

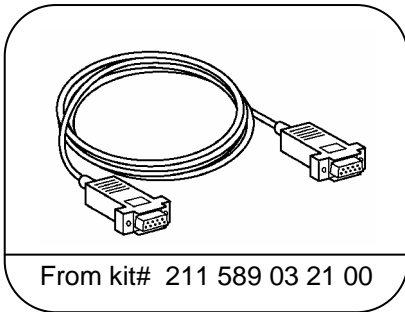

9-Pin Serial Cable

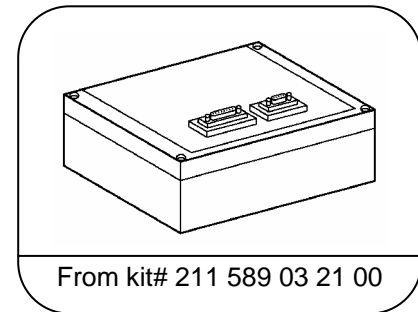

Module Box

Special Tool Information

Special Tool Number	Group/ Category	Description	Dir Net
W 000 589 13 99 30 ¹⁾	00/ B	Blade; MCP/ JPT/ SPT	\$ 41.00
W 220 589 01 99 50 ¹⁾	00/ B	Blade Holder	\$ 9.00
W 352 589 02 37 00 ²⁾	54/ C	Tension Tool; Cable Tie	\$ 404.00
W 129 589 00 91 00 ³⁾	77/ K	Plug Set; Hydraulic	\$ 98.00
W 110 589 03 59 00 ⁴⁾	72/ K	Mounting Wedge	\$ 19.50
W 211 589 04 21 01 ^{5,7)}	54/ B	SBC Adapter 2005	\$ 15.00
W 211 589 03 21 00 ^{6,7)}	54/ B	SBC Flash Adapter Set	\$ 9.75
From kit W211 589 03 21 00 ⁸⁾	54/ B	9-pin Serial Cable	N/A
From kit W211 589 03 21 00 ⁸⁾	54/ B	Module Box	N/A

Note:

¹⁾ Special Tool W 000 589 13 99 30 is interchangeable with W 220 589 01 99 61. Special Tool W 000 589 13 99 30 is the latest replacement for an existing Special Tool W 220 589 01 99 61, released and automatically delivered to all Mercedes-Benz dealers in the Wiring Harness Repair Kit: Special Tool W 220 589 01 99 00 (and later as W 220 589 02 99 00).

²⁾ Special Tool W 352 589 02 37 00 will be released and automatically delivered 1 per each Mercedes-Benz dealer.

³⁾ This required Special Tool should already be in stock at each Mercedes-Benz dealer location.

⁴⁾ This is a sample Special Tool number provided for your reference.

⁵⁾ Special Tool kit W211 589 04 21 01 will be released and automatically delivered to each Mercedes-Benz dealer.

⁶⁾ Use only 9-pin serial cable (W 211 589 03 21 02) and module box (W 211 589 03 21 03) from Special Tool kit W 211 589 03 21 00. Do not use 47-pin adapter cable (W 211 589 03 31 01).

⁷⁾ This Special Tool is not available for dealer order. Because of limited quantities, MBUSA will allocate initial distribution and replacement units as needed on a case-by-case basis. To inquire, please call 201-573-2741.

⁸⁾ These Special Tools were part of the SBC Flash Adapter Set (W 211 589 03 21 00); they cannot be ordered individually.

Required Equipment Information

Part Number	Description	MFR.
275-ST-BBE-2.5 ¹⁾	Brake Bleeder, Stierius	Bodo Stier GmbH (via Power Probe)

Note:

Brake bleeder is available via the MBUSA Standard Service Equipment Program (SSEP) at 1-888-458-4040.

¹⁾ This item was released and automatically delivered to all Mercedes-Benz dealers who did not procure the unit via the MBUSA Standard Service Equipment Program. As a Special Tool, this unit is identified with, and can be ordered using, the MBUSA Special Tool Number: W 900 589 01 71 00.

Primary Parts Information

Qty.	Part Name	Part Number	Estimated Replacement Rate
1	Suction hose	A 230 420 04 48 05	100%
2	Hose clamp	A 005 997 19 90	100%
2	Cable clamp (Omega attachment clip)	A 000 995 52 44	100%
1	Ground wiring harness	A 230 540 92 10 05	100%
3	Cable tie	A 001 997 83 90	100%
1	Bracket (bolt-on)	A 230 545 00 47 05	100%
1	Screw (self-tapping)	N 007516 005106	100%
2.25 l	Brake fluid ¹⁾	A 000 989 08 07 01	100%

NOTE:

THE FOLLOWING SECONDARY PART(S) IS/ARE NOT TO BE ORDERED IN EQUAL QUANTITIES AS THE PRIMARY PART(S). THEREFORE DO NOT PACKAGE OR KIT CAMPAIGN PARTS TOGETHER SINCE NOT ALL VEHICLES WILL REQUIRE THESE PARTS.

Secondary Parts Information

Qty.	Part Name	Part Number	Estimated Replacement Rate
1	SBC Hydraulic unit	A 005 431 71 12 05 ²⁾ A 005 431 79 12 05 ³⁾	65%
1	Bracket (clamp-on)	A 230 545 01 47 05	<1%

Note:

- ¹⁾ Submit as local purchase "BRAKEFL01653" quantity of 1. (handling is included).
- ²⁾ The following vehicles require the SBC Hydraulic Unit with part number A 005 431 71 12 05 (32 MHz):
- Vehicles with code 802
 - Vehicles with code 803 without code 053
- ³⁾ The following vehicles require the SBC Hydraulic Unit with part number A 005 431 79 12 05 (40 MHz):
- Vehicles with code 803 and code 053
 - Vehicles with code 804

Note:

- Please be aware that only the part number(s) referenced in the Campaign Bulletin is/are approved for use to repair the vehicle. Repairs performed using any other part(s) will not have been performed in accordance with the campaign. Accordingly, warranty claims submitted with reference to an improper part number(s) will be denied.
- The following allowable labor operation should be used when submitting a warranty claim for this repair:

Warranty Information (MODEL 230)**Note:**

In the event that SBC hydraulic unit replacement becomes necessary based on the serial number range check performed in Subject A of the campaign procedure, use Repair 3 or 4 to submit a claim. If the SBC hydraulic unit needs to be replaced for reasons other than the serial number, complete and close the Recall Campaign and refer to Netstar message titled "Extended Limited Warranty on SBC Hydraulic Units" dated May 5, 2006.

Repair 1 (Check hydraulic unit, mount ground wire and bracket, replace suction hose)

Operation: Diagnosis assistance system (DAS), connect & disconnect (02-4762)
SBC hydraulic unit – number range, check (02-4821)
Suction line-SBC system (DAS connected), replace (02-4845)
Ground wire & bracket-SBC wiring harness, install (02-4846)

Damage Code	Operation Number	Labor Time (hrs.)	Model Indicator(s)
43 911 01 7	02-4762	0.2 hrs.	R1, R2, R3
	02-4821	0.1 hrs.	R1, R2, R3
	02-4845	2.3 hrs.	R1
	02-4845	2.4 hrs.	R2, R3
	02-4846	0.4 hrs.	R1, R2, R3

Repair 2 (Check hydraulic unit, mount ground wire and bracket, replace suction hose, perform software update)

Operation: Diagnosis assistance system (DAS), connect & disconnect (02-4762)
SBC hydraulic unit – number range, check (02-4821)
Suction line-SBC system (DAS connected), replace (02-4845)
Ground wire & bracket-SBC wiring harness, install (02-4846)
Software – (DAS connected), install (02-4886)

Damage Code	Operation Number	Labor Time (hrs.)	Model Indicator(s)
43 911 01 7	02-4762	0.2 hrs.	R1, R2, R3
	02-4821	0.1 hrs.	R1, R2, R3
	02-4845	2.3 hrs.	R1
	02-4845	2.4 hrs.	R2, R3
	02-4846	0.4 hrs.	R1, R2, R3
	02-4886	0.4 hrs.	R1, R2, R3

Repair 3 (Check, replace hydraulic unit, mount ground wire and bracket, replace suction hose)

Operation: Diagnosis assistance system (DAS), connect & disconnect (02-4762)
SBC hydraulic unit – number range, check (02-4821)
SBC hydraulic unit (DAS connected), replace (02-4822)
(**Note:** 02-4822 Includes suction hose replacement)
Ground wire&bracket-SBC wire harn.(hyd.unit rem.),mount (02-4831)

Damage Code	Operation Number	Labor Time (hrs.)	Model Indicator(s)
43 911 01 7	02-4762	0.2 hrs.	R1, R2, R3
	02-4821	0.1 hrs.	R1, R2, R3
	02-4822	3.3 hrs.	R1
	02-4822	3.4 hrs.	R2, R3
	02-4831	0.3 hrs.	R1, R2, R3

Repair 4 (Check, replace hydraulic unit, mount ground wire and bracket, replace suction hose, perform software update)

Operation: Diagnosis assistance system (DAS), connect & disconnect (02-4762)
 SBC hydraulic unit – number range, check (02-4821)
 SBC hydraulic unit (DAS connected), replace (02-4822)
 (**Note:** 02-4822 Includes suction hose replacement)
 Ground wire&bracket-SBC wire harn.(hyd.unit rem.),mount (02-4831)
 Software – (DAS connected), install (02-4886)

Damage Code	Operation Number	Labor Time (hrs.)	Model Indicator(s)
43 911 01 7	02-4762	0.2 hrs.	R1, R2, R3
	02-4821	0.1 hrs.	R1, R2, R3
	02-4822	3.3 hrs.	R1
	02-4822	3.4 hrs.	R2, R3
	02-4831	0.3 hrs.	R1, R2, R3
	02-4886	0.4 hrs.	R1, R2, R3

NOTE REGARDING CUSTOMER REIMBURSEMENT

Reimbursement to customers for repairs performed prior to this recall:

If the customer already paid to have this recall campaign condition repaired and provides adequate documentation to support their claim of a non-warranty repair of this item, they may be eligible to receive reimbursement.

Requests for reimbursement may include parts, labor, fees and taxes.

Reimbursement is limited to the amount the repair of the SBC hydraulic Unit, suction hose, ground wire and bracket, and related parts associated to these replacements (ex. screws, clamps, brake fluid) would have cost if completed by an authorized Mercedes-Benz dealer under this campaign.

Submit a warranty claim, utilizing Damage Code 43911018 as a sublet, utilizing the sublet code of "SUB." Sublet repairs require dealer text as stated in the Warranty Policies and Procedures Manual. Repair date should be the date that the customer paid for the repair.

Note:

Please note the claim submitted for customer reimbursement will **not** close the campaign (if still open).If the customer is still in possession of the vehicle with an open campaign, please arrange to close the campaign in the usual manner as described in this bulletin.

Safety Recall #2005070007

August, 2005

Dear Mercedes-Benz Owner

This notice is sent to you in accordance with the requirements of the National Traffic and Motor Vehicle Safety Act. WE SENT YOU THIS NOTICE BECAUSE WE ARE CONCERNED ABOUT YOUR SAFETY.

DaimlerChrysler AG (DCAG), the manufacturer of Mercedes-Benz vehicles, has decided that a defect which relates to motor vehicle safety exists in certain Model Year 2004 E-Class and SL-Class vehicles equipped with Sensotronic Brake Control (SBC). Mercedes-Benz USA, LLC (MBUSA) therefore has initiated a recall of these vehicles. Our records indicate that your vehicle is included in the affected population of vehicles.

The SBC brake system in certain E-Class and SL-Class vehicles, in certain instances, may prematurely shift to the hydraulic back up mode due to a loosening of the ground wire harness connection over time, or due to premature failure of the hydraulic pump. In the hydraulic back up mode, the driver has braking power sufficient to stop the vehicle, although greater brake pedal pressure is required and the brake pedal travel will be noticeably longer which could lead to a vehicle crash.

Your authorized Mercedes-Benz dealer has available a bracket and replacement ground wire that it will install on your vehicle's SBC pump unit to correct the situation described above by preventing loosening of the new ground wire harness connection. Additionally dealers will check a production date range on the SBC hydraulic pump and if required replace the pump. This service will be provided free of charge. The working time required is approximately 4 hours. Your authorized Mercedes-Benz dealer will also check for other needed repair measures applicable to your vehicle which may increase the required working time. Please contact your authorized Mercedes-Benz dealer for additional information and to schedule an appointment at your earliest convenience. Please mention Recall Campaign #2005 070007.

If you are no longer the vehicle owner, or have a change of address, please complete the reverse side of this letter and return the complete letter in the enclosed envelope. If this is a leased vehicle and the lessor and registered owner receive this notice, please forward this information by first class mail to the lessee. If you have paid to have this recall condition corrected prior to this notice you may be eligible to receive reimbursement. Please see the reverse side of this notice for details.

Please contact your authorized Mercedes-Benz dealer should you have any questions or encounter any difficulty regarding this recall. If your dealer is unable to remedy your situation please contact us at 1-(800) FOR-MERCEdes (1-800-367-6372).

If an authorized Mercedes-Benz dealer or Mercedes-Benz USA, LLC, fails or is unable to perform this service without charge within 60 days, pursuant to law 49 U.S.C. Chapter 301, you may submit a complaint to the Administrator, National Highway Traffic Safety Administration, 400 Seventh Street, S.W., Washington, D.C. 20590 or call the toll-free Auto Safety Hotline at 1-888-327-4236 (TTY 1-800-424-9153); or go to <http://www.safercar.gov>.

We apologize for any inconvenience this situation may cause you.

Sincerely

Klaus Ulkann
Vice President, Customer Services

P-RC-2005070007