

**Nm** Front axle brake caliper

Number	Designation		Model 211 except model 211.076/ 077/276/ 277	Model 211.076/ 077/276/ 277
BA42.10-P-1002-10H	Bleed screw to brake caliper	Nm	14	14

**Nm** Front axle brake caliper

Number	Designation		Model 216 except model 216.374/377/379	Model 216.374/377/379
BA42.10-P-1001-10M	Bleed screw to brake caliper	Nm	14	16

**Nm** Front axle brake caliper

Number	Designation		Model 221 except model 221.074/077/174/ 177/179	Model 221.074/077/174/ 177/179
BA42.10-P-1001-10M	Bleed screw to brake caliper	Nm	14	16

**Nm** Front axle brake caliper

Number	Designation		Model 219.372/376/377	Model 219.322/354/356 / 357/375
BA42.10-P-1002-10B	Bleed screw to brake caliper	Nm	14	14

**Nm** Rear axle brake caliper

Number	Designation		Model 211 except model 211.076/077/ 276/277	Model 211.076/077/ 276/277

BA42.10-P-1001-12H	Bleed screw to brake caliper	Nm	14	14
--------------------	------------------------------	----	----	----

**Nm** Rear axle brake caliper

Number	Designation	Model 216 except 216.374/ 377/379	Model 216.374/ 377/379	Model 221 except model 221.074/ 077/174/ 177/179	Model 221.074/ 077/174/ 177/179	
BA42.10-P-1001-12M	Bleed screw to brake caliper	Nm	14	23	14	23

**Nm** Rear axle brake caliper

Number	Designation	Model 219	
BA42.10-P-1001-12B	Bleed screw to brake caliper	Nm	14

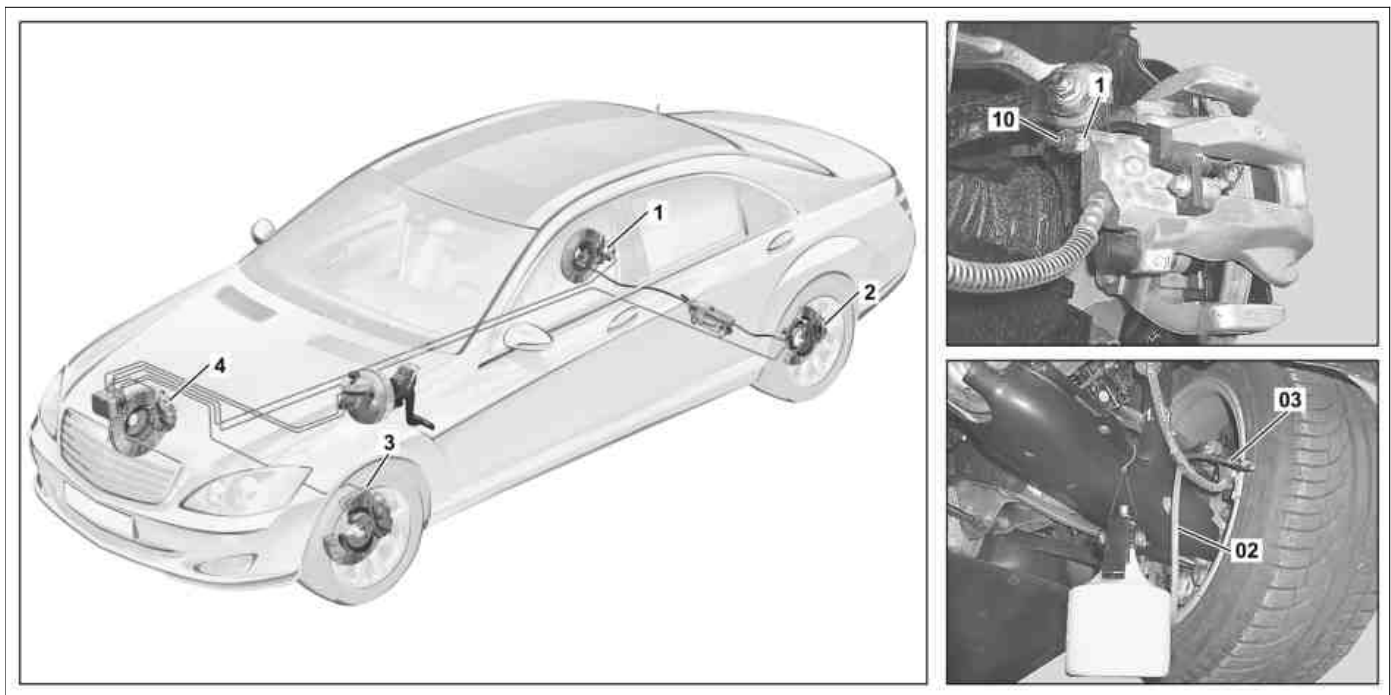

P42.10-2534-09

**Opening sequence on 1, 2 or 4 piston brake calipers on front axle**

## Opening sequence on 6 or 8 piston brake calipers on front axle

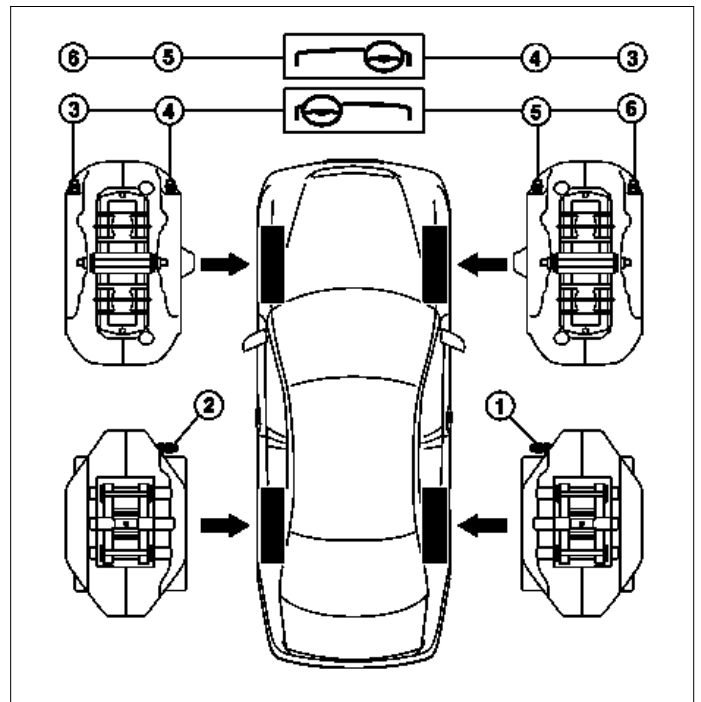

P42.00-2110-12

## Opening sequence for model 221 with code (Z07) maximum protection

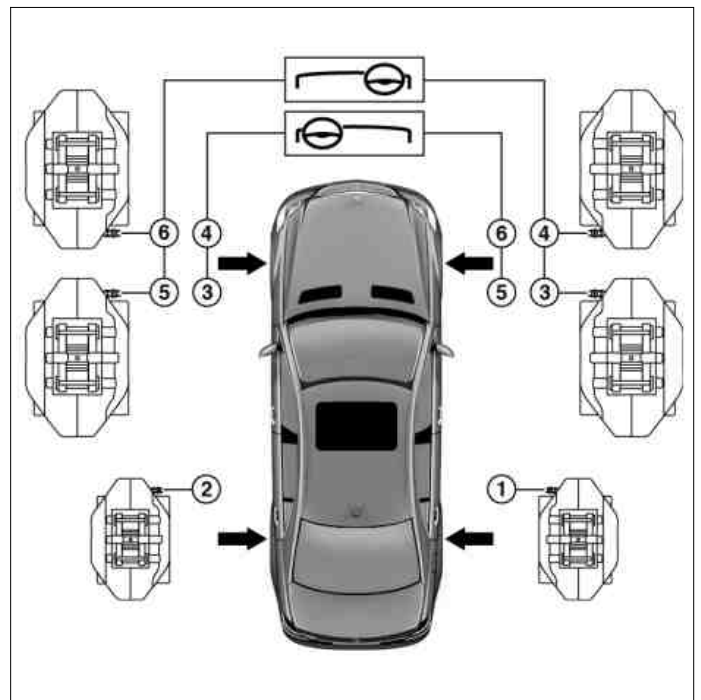

P42.10-2744-12

- 1 Set bleeding pressure on filling and bleeding unit to 2 bar.
- 2 Remove caps (10) for bleed screws (1, 2, 3, 4, 5, 6) on brake calipers.
- 3 Fit bleed wrench (03) and bleed hose (02) on bleed screw (1).
- 4 Open bleed screw (1).

- 5.1 Bleed the hydraulic system of the brake system (after the hydraulic system was opened for repair): Fully depress brake pedal repeatedly, until new bubble-free brake fluid flows out at the bleed screw (1).
  - ⚠ To bleeding the brake system correctly it is absolutely essential to pump the brake pedal throughout the entire bleeding process. Otherwise brake system malfunctions and a failure of the brake system can occur due to remaining residual air.
  - ⚠ In order to avoid the intake of air, do not pump the brake pedal in a jerking manner, but gradually release.
  - ℹ The bleed screw (1) can remain open during the entire pumping process.
  - ℹ Required total quantity of brake fluid: approx. 1.5 l.

- 5.2 Replace brake fluid (service 4, hydraulic system of brake system was not previously opened for repair): Keep bleed screw (1) open until new brake fluid flows out.
  - ℹ Pumping the brake pedal not required.

- 7 Repeat process at bleed screws (2, 3, 4, 5, 6).
  - ℹ The numbering of the bleed screws (1, 2, 3, 4, 5, 6) indicates the opening sequence.

 Required total quantity of brake fluid: approx. 0.75 l.

 For 6, or 8-piston brake calipers on the front axle and for vehicles with code (Z07) Maximum protection: Note different sequence for left and right-hand drive vehicles.

6 Close bleed screw (1).

8 Detach bleed hose (02) and bleed wrench (03) and fit caps (10) to bleed screws (1, 2, 3, 4, 5, 6).