

**Engine 157, 276, 278****Shown on engine 276 in model 212.095/195**

- 1 *Belt pulley/vibration damper*
- 2 *Tensioner pulley*
- 3 *Coolant pump belt pulley*



P13.22-2190-12

**Shown: engine 276 without hydraulic power steering pump**

- 1 *Belt pulley/vibration damper*
- 2 *Tensioner pulley*
- 3 *Coolant pump belt pulley*
- 5 *Alternator belt pulley*
- 6 *Guide pulley*
- 7 *Guide pulley*
- 10 *A/C compressor belt pulley*

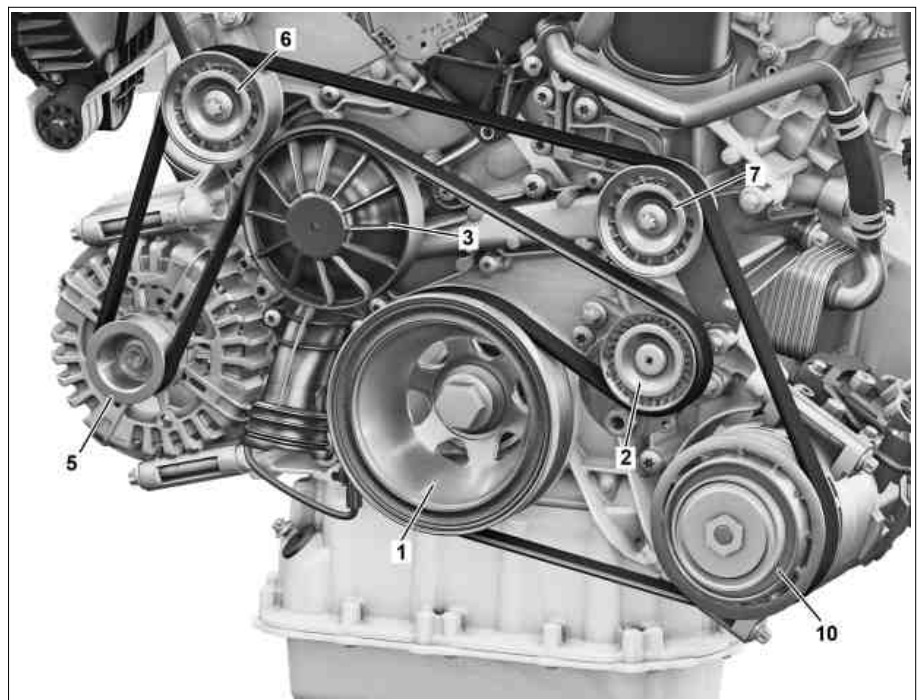

P13.22-2158-06

**Shown: engine 276 with hydraulic power steering pump**

- 1 Belt pulley/vibration damper
- 2 Tensioner pulley
- 3 Coolant pump belt pulley
- 5 Alternator belt pulley
- 6 Guide pulley
- 9 Belt pulley for hydraulic power steering pump
- 10 A/C compressor belt pulley

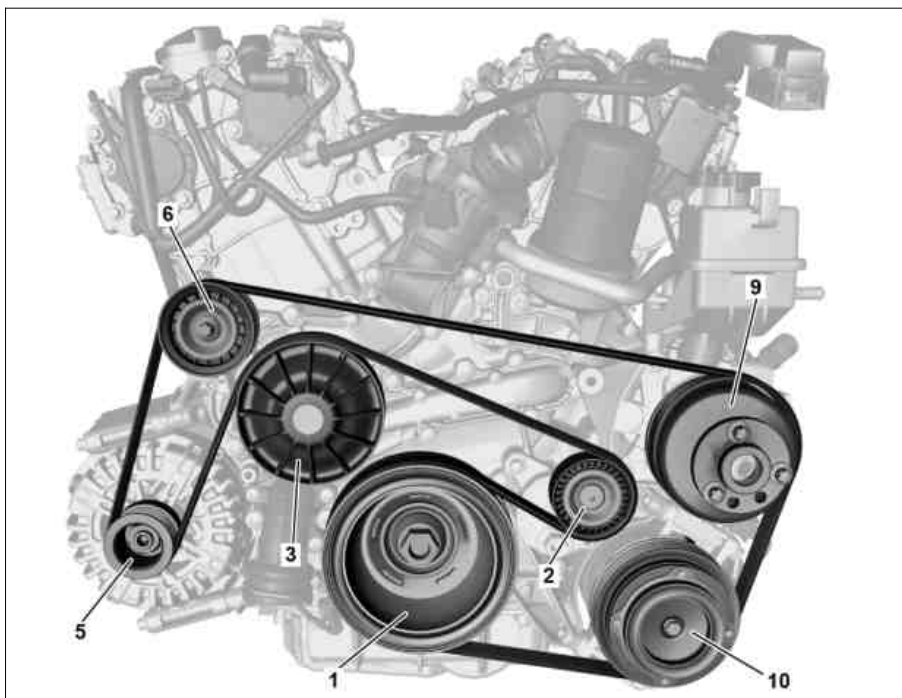

P13.22-2162-06

**Shown: engine 157, 278 with code 487 (Active Body Control (ABC))**

- 1 Belt pulley/vibration damper
- 2 Tensioner pulley
- 3 Coolant pump belt pulley
- 4 Active Body Control (ABC) belt pulley
- 5 Alternator belt pulley
- 6 Guide pulley
- 7 Guide pulley
- 8 Guide pulley
- 10 A/C compressor belt pulley

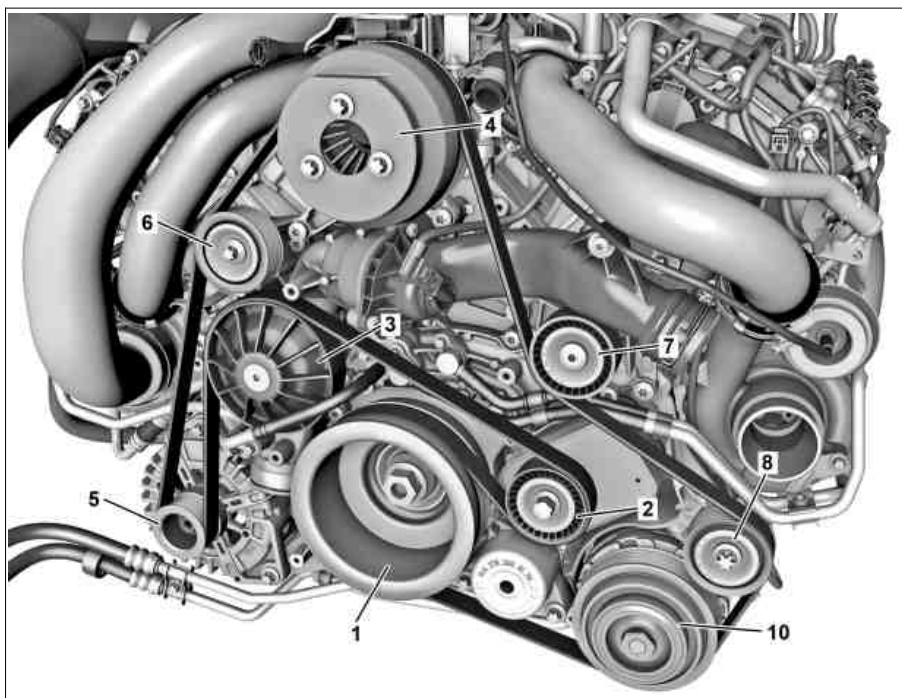

P13.22-2159-06

**Shown: engine 157, 278 without code 487(Active Body Control (ABC))**

- 1 Belt pulley/vibration damper
- 2 Tensioner pulley
- 3 Coolant pump belt pulley
- 4b Belt pulley for upper guide pulley/ power steering pump
- 5 Alternator belt pulley
- 6 Guide pulley
- 7 Guide pulley
- 8 Guide pulley
- 10 A/C compressor belt pulley

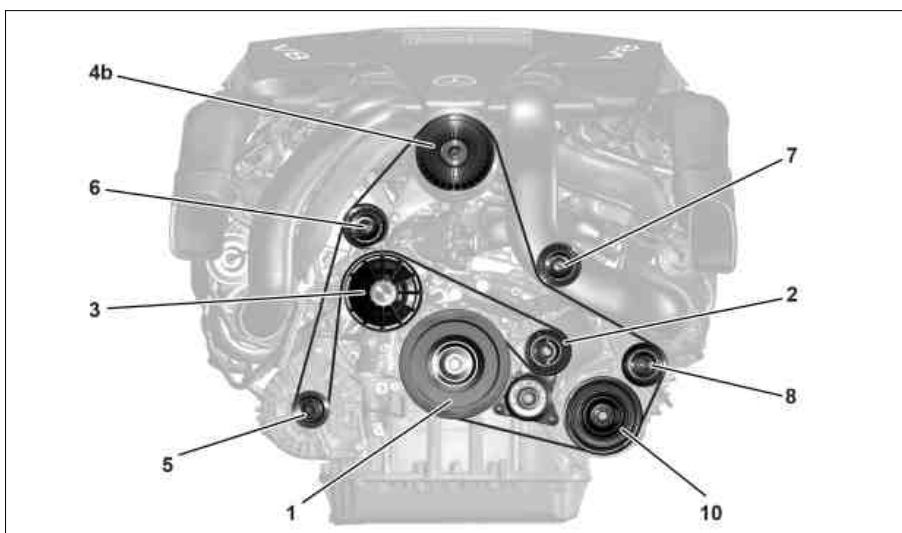

P13.20-2089-05

**Shown: engine 157, 278 with code ME05 (HYBRID DRIVE 80KW VARIANT (INCLUDING PLUG-IN))**

- 1 *Belt pulley/vibration damper*
- 2 *Tensioner pulley*
- 3 *Coolant pump belt pulley*



P13.22-2199-12

**Shown: engine 276.8 with code 468 (ACTIVE CURVE SYSTEM)**

- 1 *Belt pulley/vibration damper*
- 2 *Tensioner pulley*
- 3 *Coolant pump belt pulley*
- 5 *Alternator belt pulley*
- 6 *Guide pulley*
- 10 *A/C compressor belt pulley*
- 11 *Hydraulic pump belt pulley*

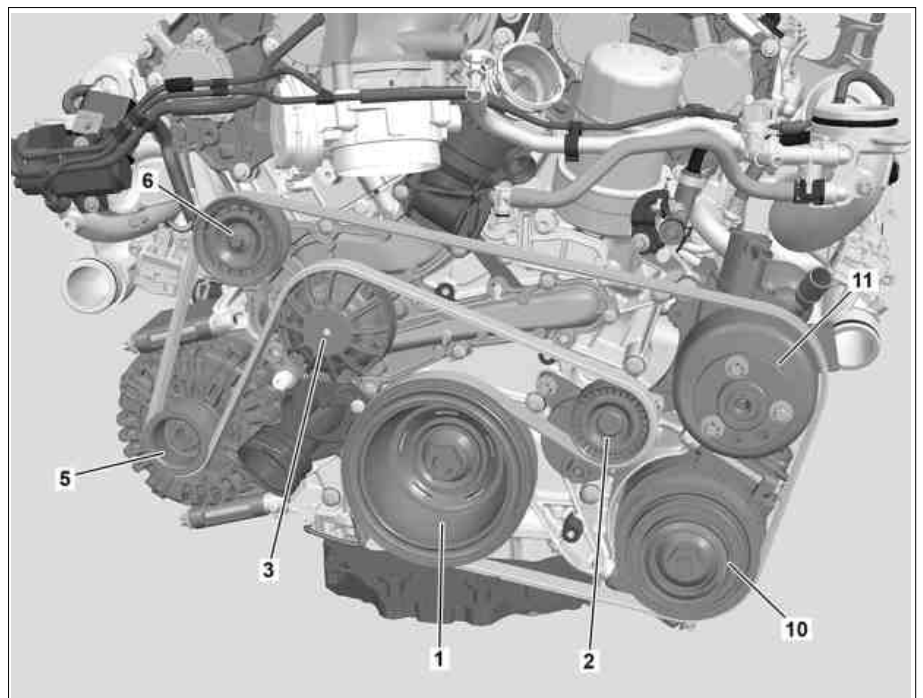

P13.20-2144-06

- 1 Check installation position of poly-V belt.