

Document number: pe54.10-p-2101-97Kf

Document title: Wiring diagram of vehicle electrical system control unit

Code:	Designation:	Position:
A0	Color code key	19L
A32	Heating systems recirculation unit	
CAN B	Interior CAN	
F32	Front prefuse	4A
F32	Front prefuse	12A
F32	Front prefuse	20A
F32	Front prefuse	26A
F32f1	Fuse 1	1B
F32f2	Fuse 2	14B
F32f3	Fuse 3	15B
F32f4	Fuse 4	25B
F32f5	Fuse 5	22B
F32f6	Fuse 6	2B
F32f7	Fuse 7	20B
F33	Rear prefuse box	54A
F33f1	Fuse 1	52B
F33f2	Fuse 2	56B
F33f3	Fuse 3	57B
F52	Fuse through-plating	29A
F52	Fuse through-plating	36A
F52f1	Fuse 1	35B
F52f2	Fuse 2	28B
G1	On-board electrical system battery	37L
G1	On-board electrical system battery	51L
G2	Alternator	29L
K40/2	Driver-side fuse and relay module	13L
K40/4	Passenger-side fuse and relay module	9L
K40/4	Passenger-side fuse and relay module	16L
K40/4	Passenger-side fuse and relay module	32L
K40/4	Passenger-side fuse and relay module	54L
K40/4f43	Fuse 43	10L
K40/5	Rear fuse and relay module	41L
K40/5	Rear fuse and relay module	57L
K40/5f61	Fuse 61	40L
M1	Starter	35L
M4/7	Engine and AC electric suction fan with integrated control	2L
N3/10	ME-SFI [ME] control unit	5L
N47-5	ESP, SPS [PML] and BAS control unit	22L
N73	EIS [EZS] control unit	26L

Document number: pe54.10-p-2101-97Kf

Document title: Wiring diagram of vehicle electrical system control unit

Code:	Designation:	Position:
N73	EIS [EZS] control unit	48L
N82/1	Vehicle power supply control unit	46A
N82/1	Vehicle power supply control unit	40A
R15	Electric suction fan series resistor	4H
U12	Valid for left-hand drive vehicles	13D
U12	Valid for left-hand drive vehicles	18D
U13	Valid for right-hand drive vehicles	15D
U13	Valid for right-hand drive vehicles	18D
W10	Ground (battery)	37H
W10	Ground (battery)	50H
W3/2	Ground (left front wheelhouse)	1E
W34/1	Ground (electronics - left footwell)	19E
W34/2	Ground (electronics - right footwell)	19E
W36	Ground (right footwell)	19G
W37	Ground (left footwell)	19G
W7	Ground (right wheelhouse in luggage compartment)	47E
X151	SBC feed circuit 30 connector	22E
X30/17	Rear voltage distributor (CAN B) connector	45L
X35/15	Module box separation point	4E
X35/63	Control unit box/engine separation point	32G
Z4/4	Circuit 30Z connector sleeve (solder connector in harness)	27G
Z4/4	Circuit 30Z connector sleeve (solder connector in harness)	57E

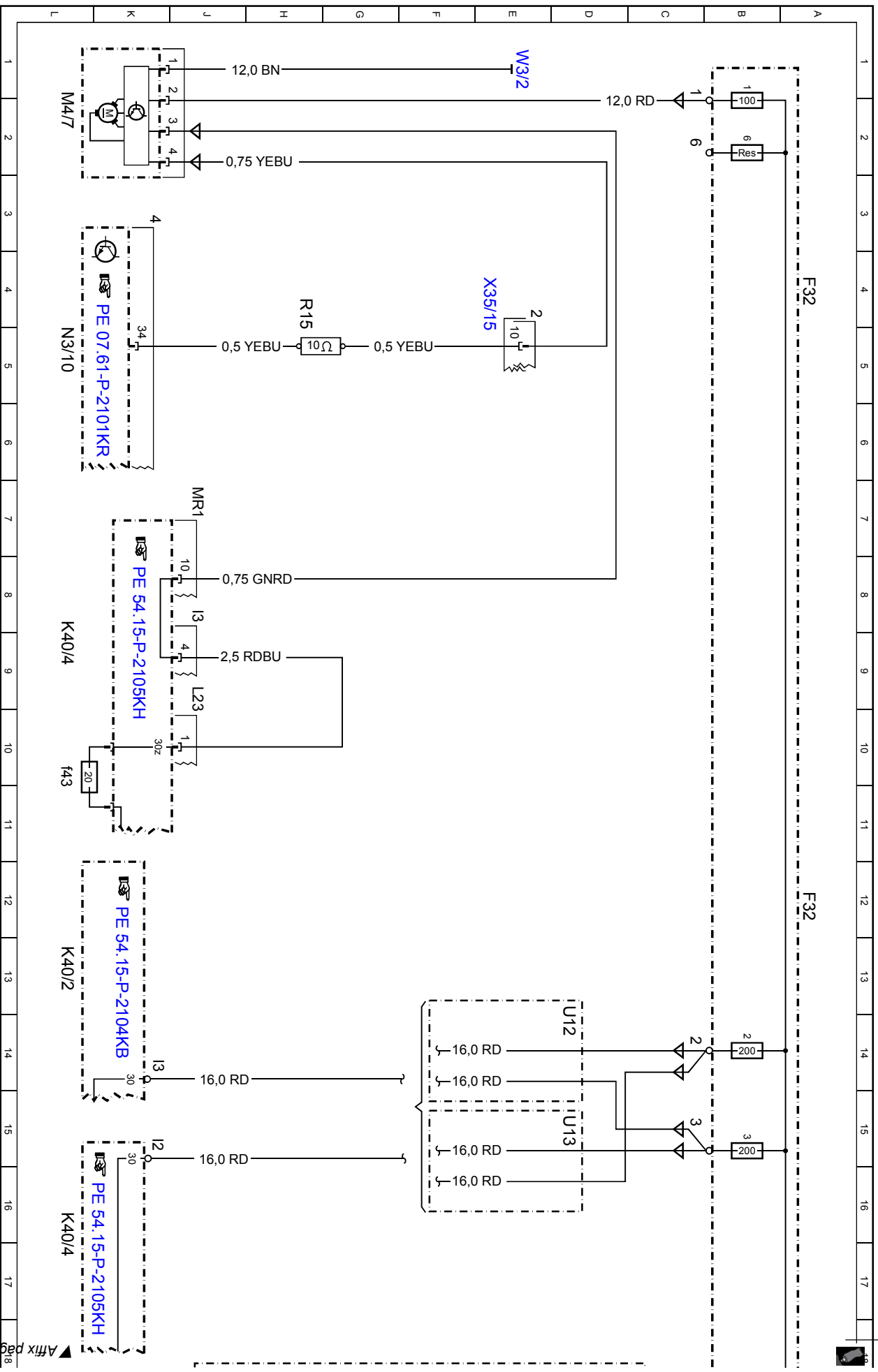

▲ Affix page 2 here

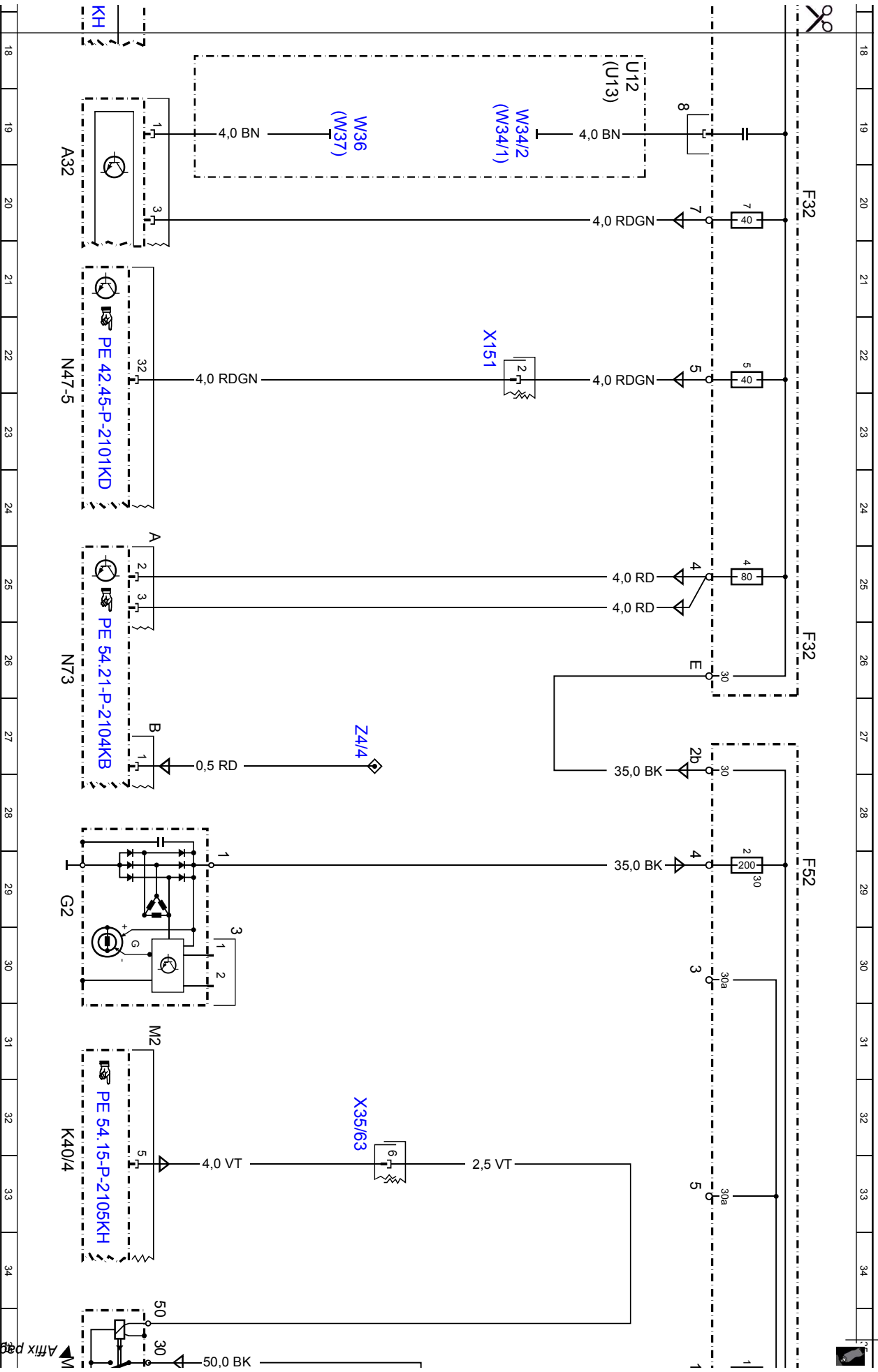

Cut here

▲ Affix page 3 here

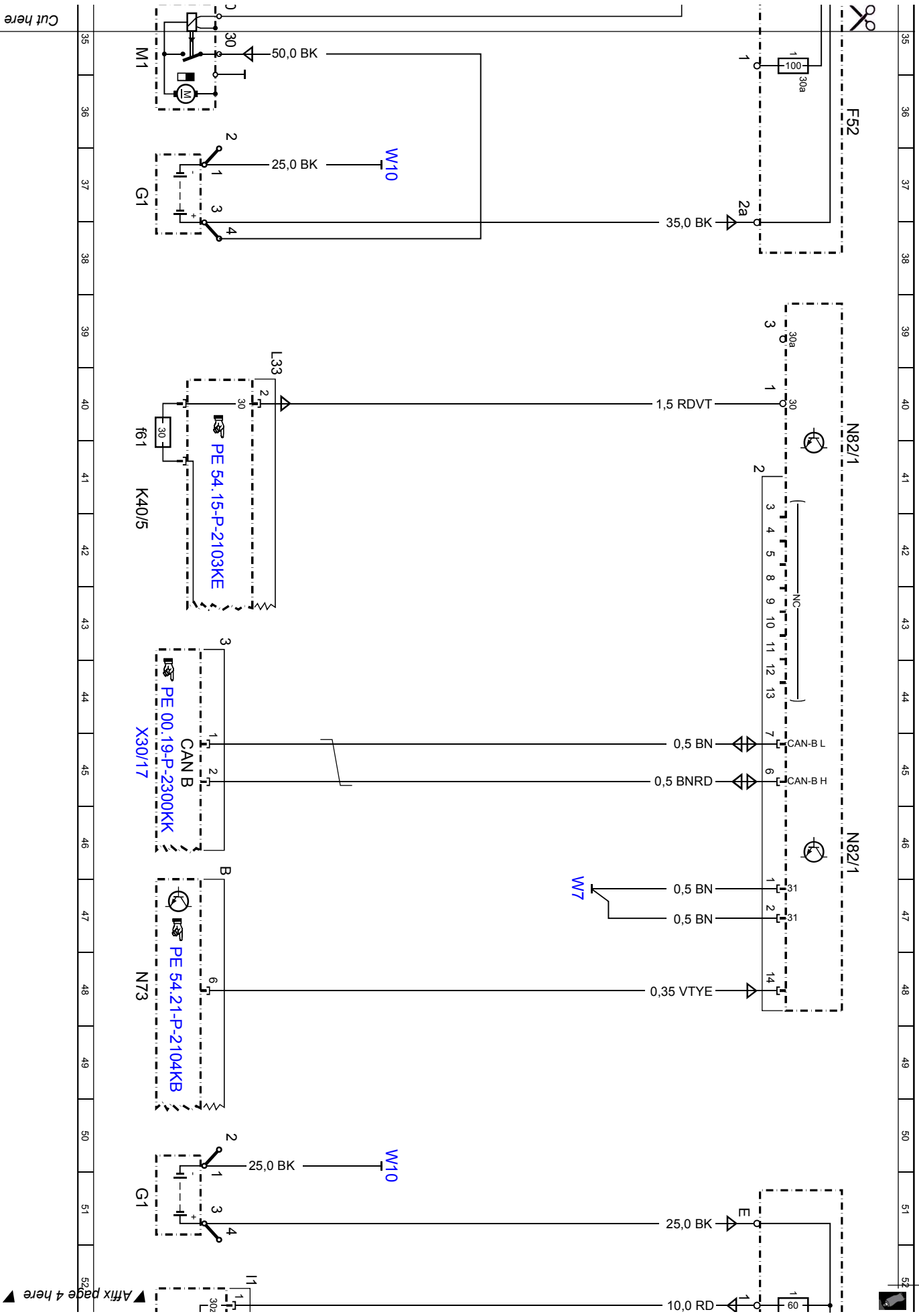

Cut here

Affix page 4 here

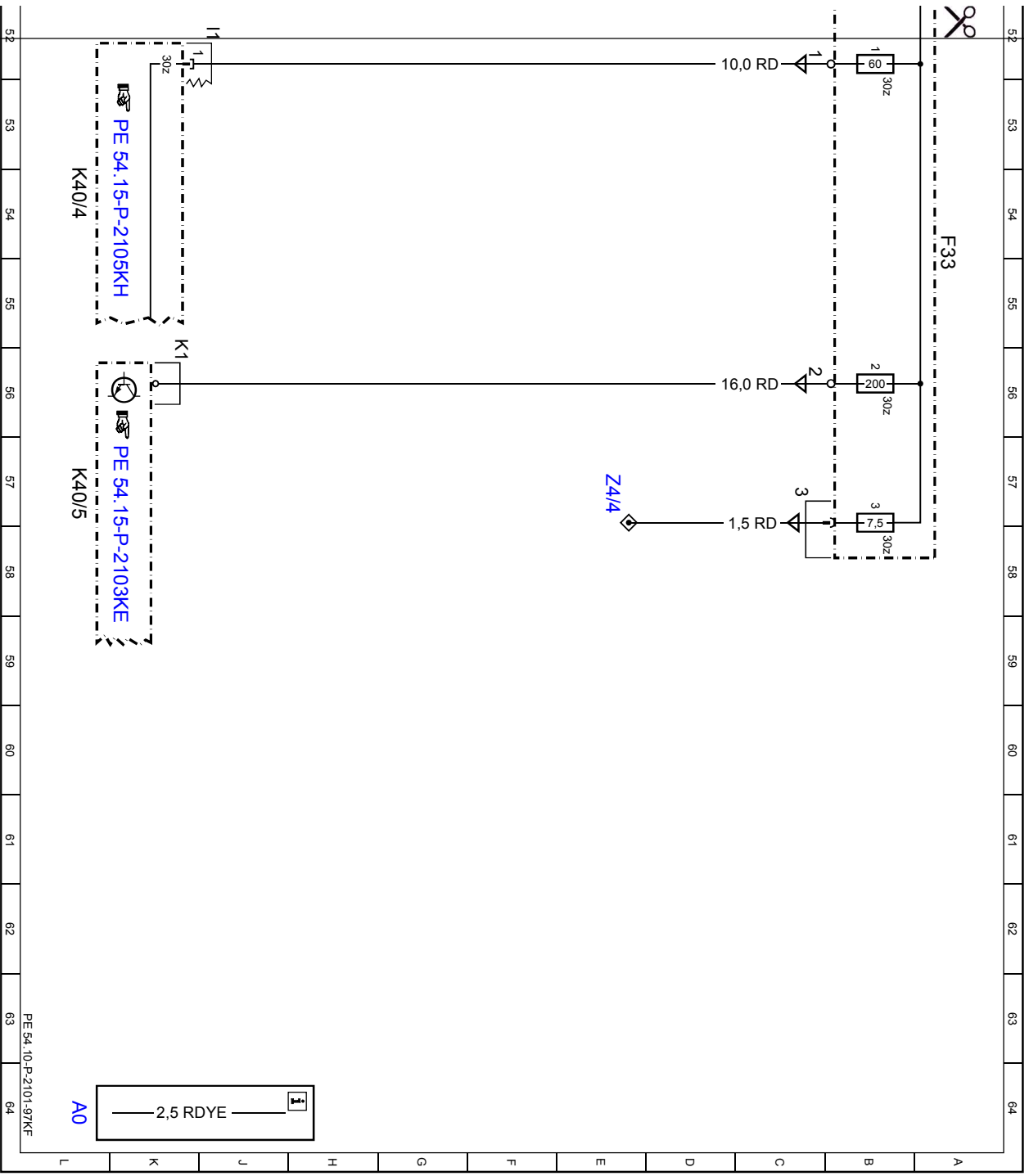

Cut here