

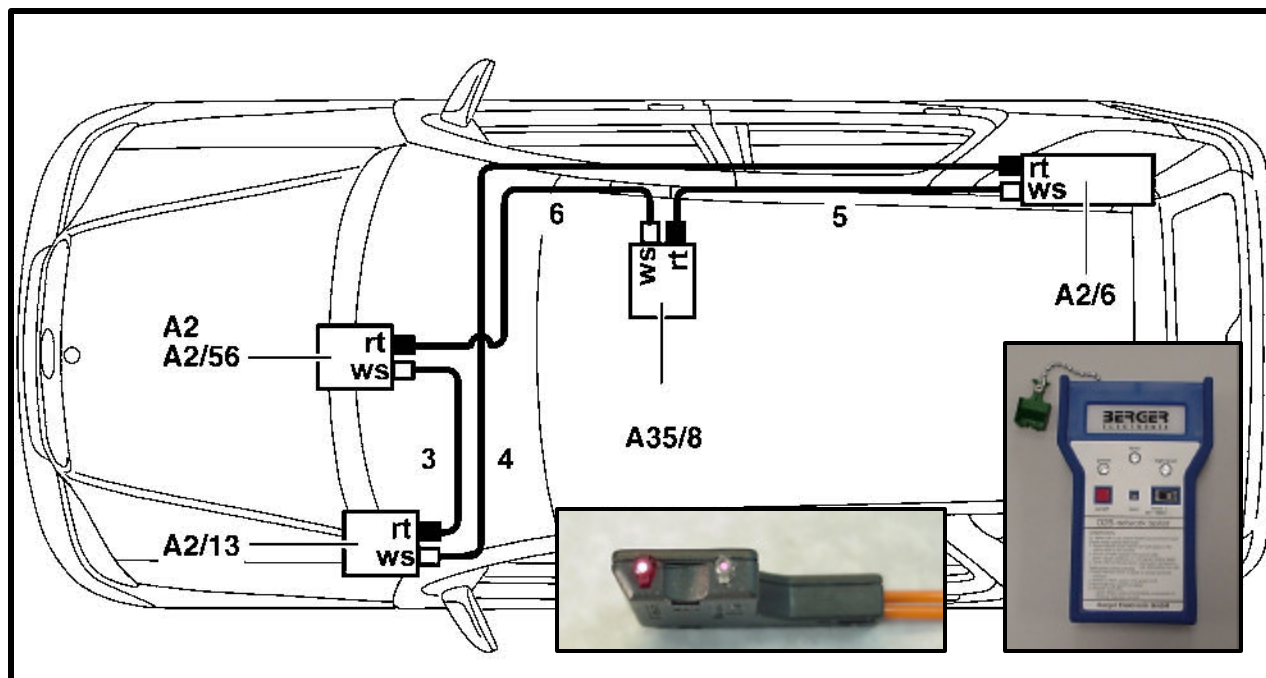

Mercedes-Benz

# Domestic Digital Bus (D2B)



These technical training materials are current as of the date noted on the materials, and may be revised or updated without notice. Always check for revised or updated information.

To help avoid personal injury to you or others, and to avoid damage to the vehicle on which you are working, you must always refer to the latest Mercedes-Benz Technical Publication and follow all pertinent instructions when testing, diagnosing or making repair. Illustrations and descriptions in this training reference are based on preliminary information and may not correspond to the final US version vehicles. Refer to the official introduction manual and WIS when available.

*Copyright Mercedes-Benz USA, LLC, 2004*

*WIS document numbers shown apply to WIS Version USA/CDN at date of writing.*

*Reproduction by any means or by any information storage and retrieval system or translation in whole or part is not permitted without written authorization from Mercedes-Benz USA, LLC or it's successors.*

*Published by Mercedes-Benz USA, LLC*

*Printed in U. S.A.*

# What is D2B?

- D2B acronym is derived from “Domestic Digital Bus”
- D2B utilizes fiber optics to transmit data and control signals in the form of light - an optical network
- D2B components convert electrical signals into light signals or pulses
- Light pulses are sent to next component using a fiber optic transceiver (FOT)
- Each component uses 2 FOT's - FOT 'out' and FOT 'in'
- Receiving D2B component converts optical data back into electrical signals and either uses the information to operate or passes the data on to the next component

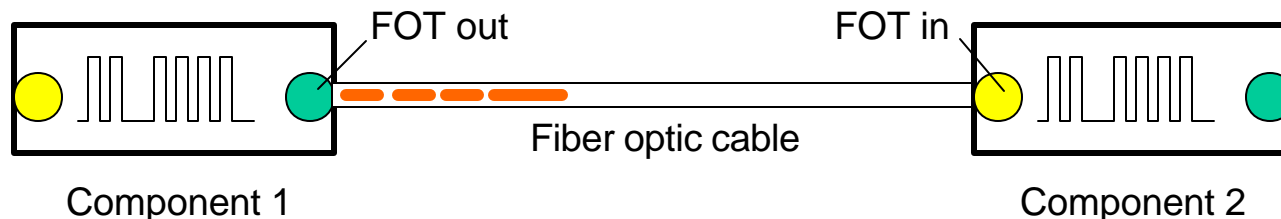

# Basic Arrangement

D2B components are connected by:

- an optical ring

*Fiber optic cable between each D2B component, connects components in series*

&

- electrical wake-up lines

*Single wire from each component is connected together using connector block or soldered 'Z' splice – star topology*

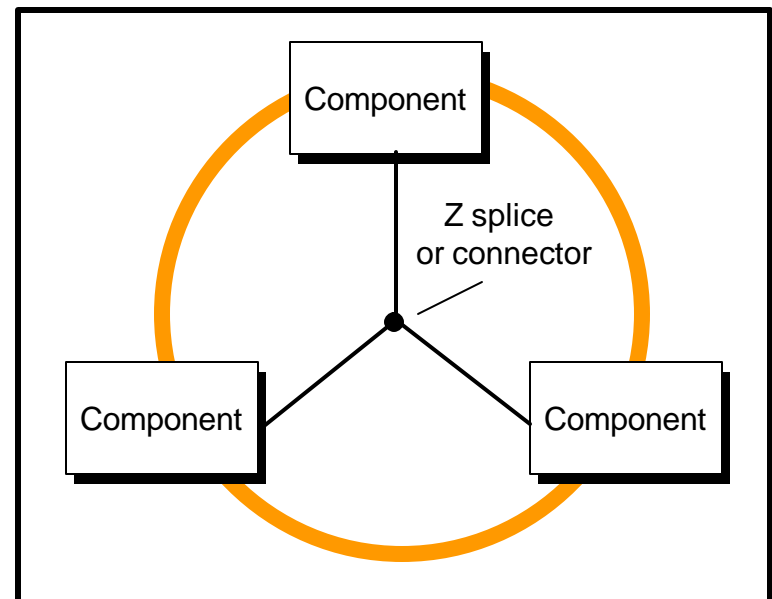

# D2B Fiber Optic Cable

## Advantages:

- Impervious to electromagnetic interference
- Lighter than wire
- Improved signal quality
- Fewer electrical connections
- Easily configured
- 5.6 MB/sec data transfer

*(~ 11 times faster than CAN C)*

## Disadvantages:

- Fragile
- Repairs not possible without special equipment

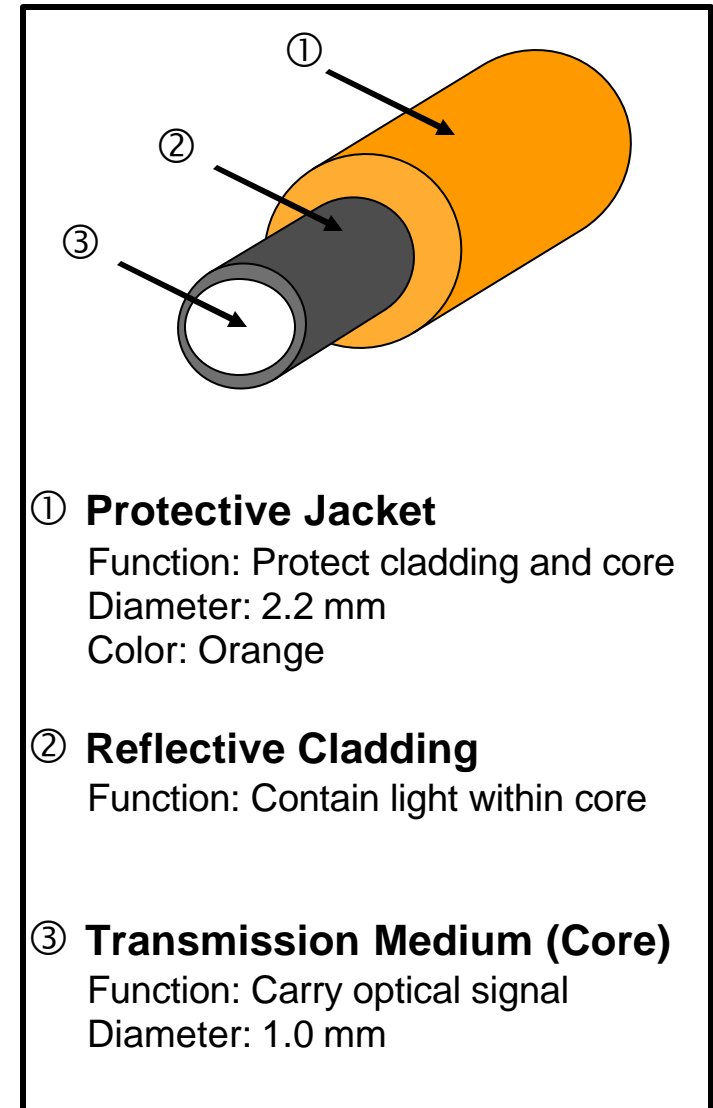

# Handle With Care!

- Light passage through a straight fiber:

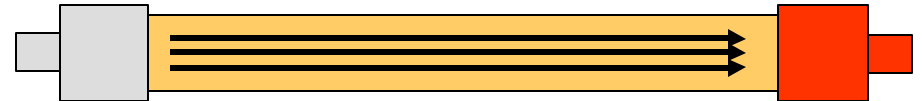

- Repairs to fiber optic cables not feasible as it requires special tools to ensure a perfect fit

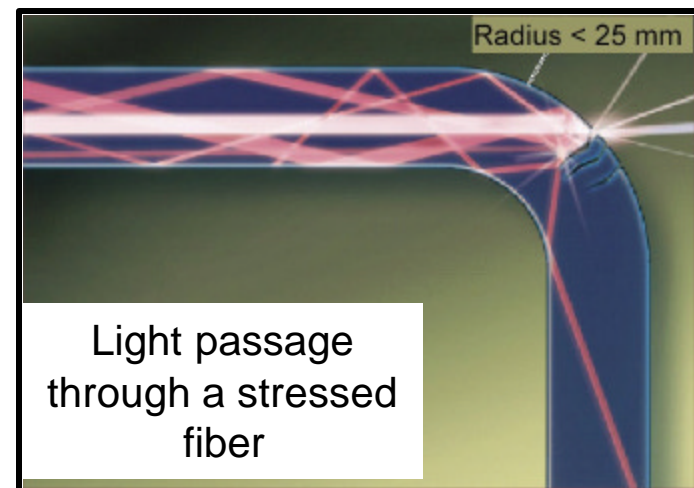
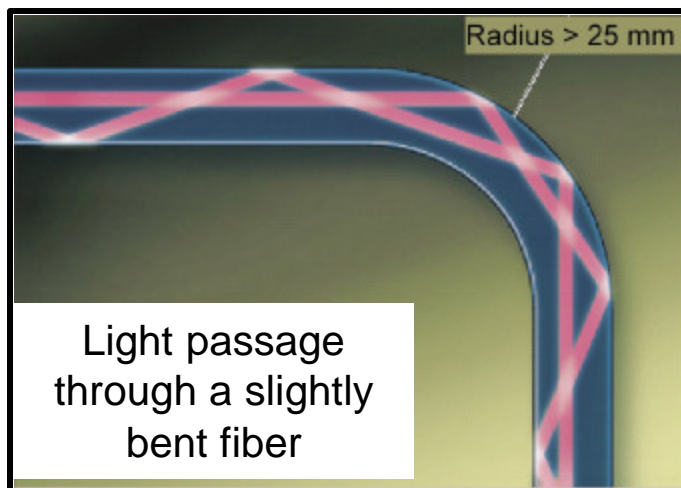
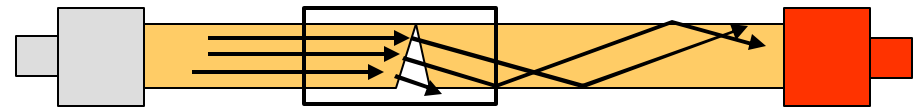

# Connection Configuration

- Optical cables have one end clear and the other end red
- Light is transmitted into the clear end
- Always ensure that ring follows a red-to-clear, clear-to-red logic
- Ensure that red end is always on the chamfered side of the connector
- In-Line couplers follow the same logic as other ring connectors

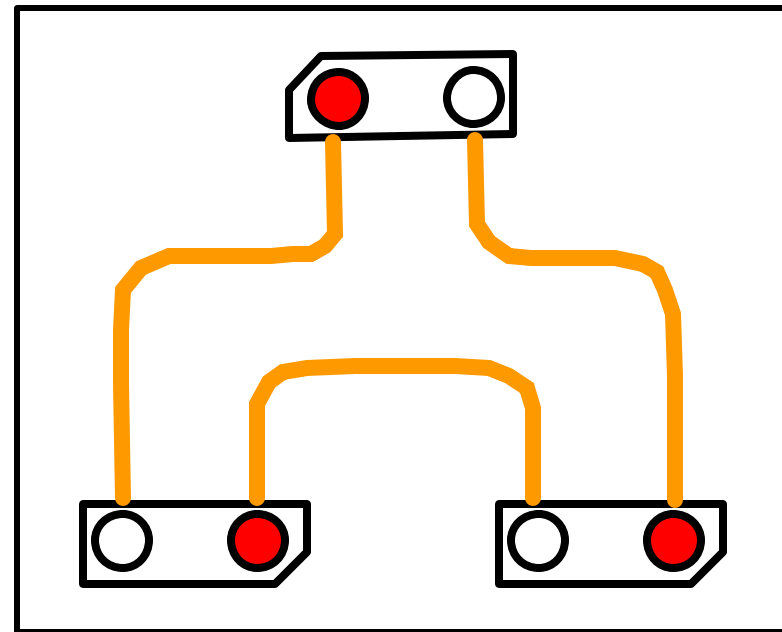

Fiber Optic Cable Layout



Coupler part # 000 545 33 84

Max. cable lengths - 0 couplers = 10m / 1 coupler = 7m / 2 couplers = 3.6m

# Ring Master

- Ring master of the D2B system is either the Radio, COMAND or MCS.
- Ring master is responsible for:
  - Storing the ring configuration
  - Providing voltage for the wake-up lines
  - Issuing an electrical wake-up signal
  - Issuing a 'ring start' optical message
  - Maintaining 'ring lock' after 'ring start'
  - Switching off the ring
  - Determining & storing fault codes related to itself and ring errors
  - Diagnostic gateway between CAN B and D2B components
  - Gateway between D2B components & CAN B
  - Performing a diagnostic wake-up upon request from SDS / DAS



Radio



COMAND



MCS



# Electrical Wake-Up Line

- Fiber Optic Transceiver's (FOT's) draw a large amount of current & need to be put to sleep whenever ring is not being used
- Wake-up line is always supplied battery voltage from D2B master
- To wake up components, a wake-up signal is sent on wake-up line from D2B Master
- Wake-up line is also used to assist diagnosis when master is instructed to by SDS / DAS

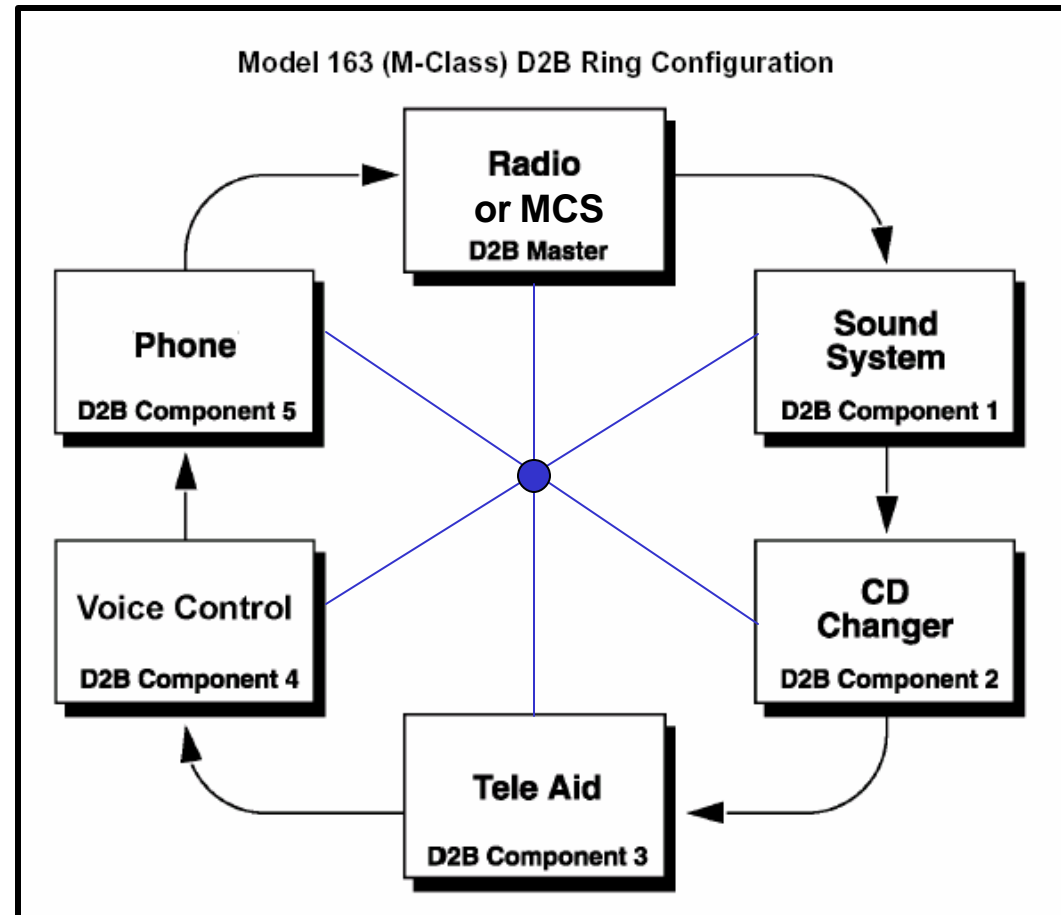

Optical   
Electrical 

Shown with optional equipment

# Electrical Wake-Up Wiring

- Wake-up lines are Z spliced on all models except:
  - 203 / 209 / 230 / 463 (which use a X30/8 connector)
- X30/8 connector block connects all wake-up lines.



Z splice

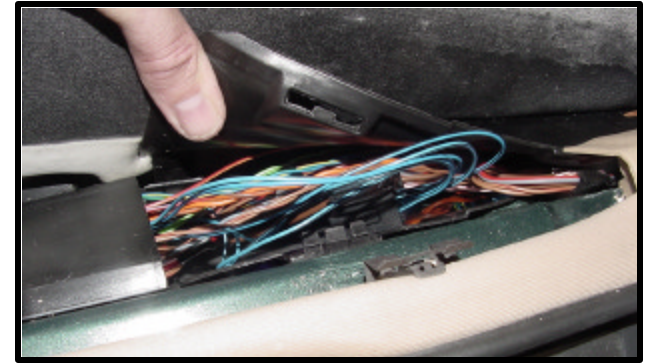

X30/8 connector block

Location: 203 / 209 = right front sill trough      230 = behind driver seat under carpet  
463 = behind dash left side near hood release

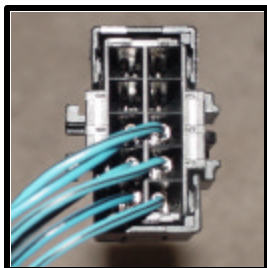

X30/8



Bridge cover pulled up into 'test position' disconnecting wake-up lines

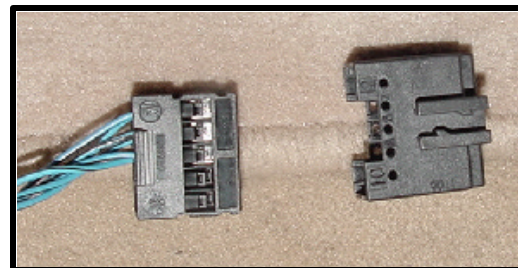

Bridge cover removed



Bridge cover removed showing bridge contacts

# Ring Start

- Master issues wake-up pulse by pulling wake-up line low for ~ 80 ms
- Components recognize this duration as a wake-up pulse and wake-up
- Master issues a optical pulse (ring start optical command)
- Optical pulse transmits around the ring and back to the master. Master now sends constant optical signal - 'ring lock'

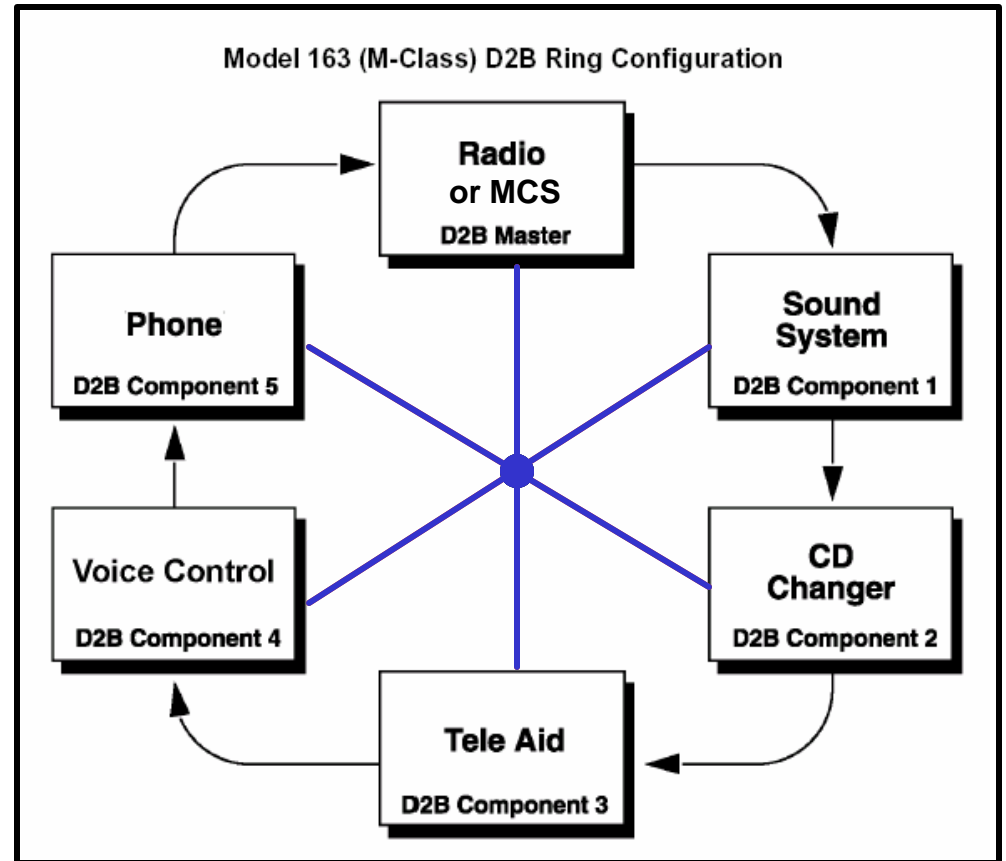
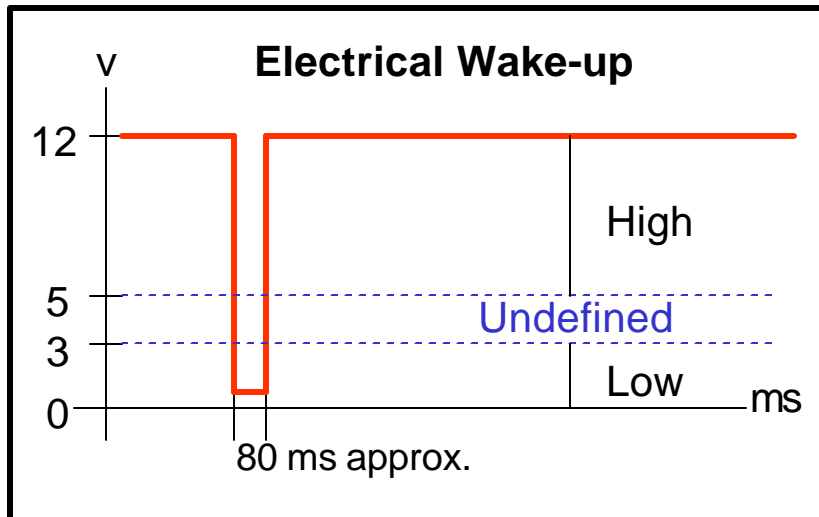

Tip: CD changer (if installed) can be heard examining the CD magazine if ring lock occurs.

# Ring Failure

Version Coding & Configuration

Signal Phasing

Electrical fault

Optical fault

Attenuation

# Version Coding & Configuration

- In order for the ring to function properly, the master MUST know the number of components on the ring and ORDER of those components with respect to the master.
- Refer to the latest Service Information or bulletin for the correct configuration:

Currently:

Date: August 2000 & October 2002  
Document No.: SI-82.64/135 & S-B-82.70/135B  
Group: 82

**NOTE: Improper version coding and / or incorrect sequencing of components may result in intermittent and / or abnormal operation of the ring.**

**Always check ring configuration is correct and corresponds to equipment level using SDS / DAS.**

# Configuration

| Vehicle                                | 163.175     | Control unit         | MCS                  |
|--|-------------|----------------------|----------------------|
| Actual configuration of D2B components |             |                      |                      |
| No.                                    | Name        | Specified value      | Actual values        |
| 360                                    | D2B master  | Radio                | Radio                |
| 361                                    | Component 1 | CD changer           | CD changer           |
| 362                                    | Component 2 | Cellular telephone   | Cellular telephone   |
| 363                                    | Component 3 | Voice control system | Voice control system |
| 364                                    | Component 4 | Sound system         | Sound system         |
| 365                                    | Component 5 | Vacant               | Vacant               |
| 366                                    | Component 6 | Vacant               | Vacant               |
| 367                                    | Component 7 | Vacant               | Vacant               |

Name - order in ring

Specified value - component list configured by using SDS / DAS

Actual value - what the master 'see's on ring start

# What is Signal Phasing?

- To set or regulate so as to be synchronized
- *Out of phase* = Operating in an unsynchronized way
- In D2B, Signal Phasing is the process of sending and receiving data according to a prescribed time table
- D2B “Master” knows when it sent data and when it should receive that data back
  - e.g. Time it takes:
    - data to reach 1<sup>st</sup> component
    - +
    - component to respond to data and send data on
    - +
    - data to reach next component ....etc

# D2B Signal Phasing Error

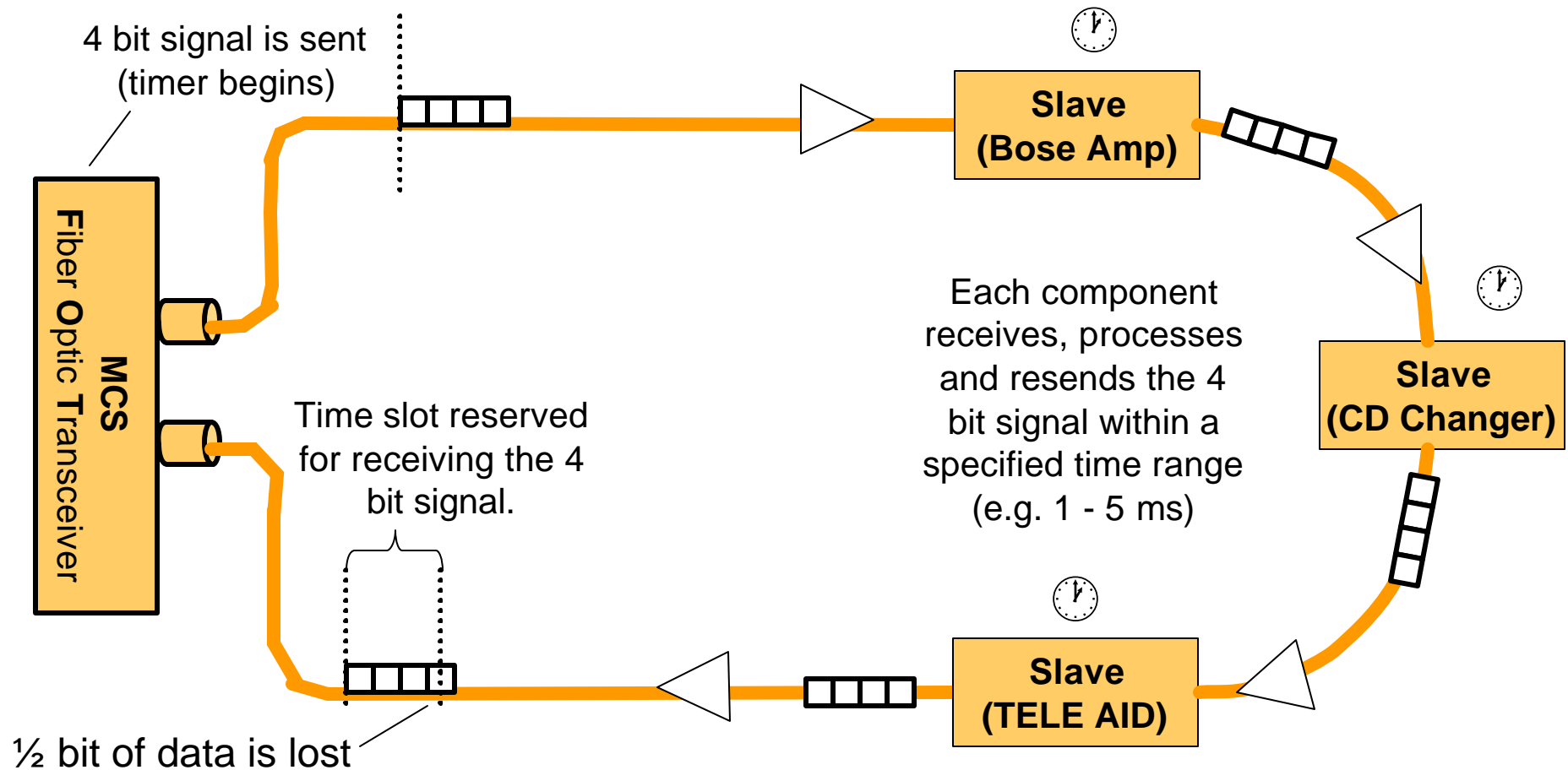

This could be due to:

- tolerances within several ring components
- excessive lengths of fiber optic cable added into the ring



# Ring Start (with open at TELE AID)

- Master issues electrical wake-up pulse
- Components wake-up except for TELE AID
- Master does not receive optical pulse back because TELE AID cannot wake-up
- 3 additional wake-up pulses are sent
- With each wake-up pulse a optical pulse was also issued

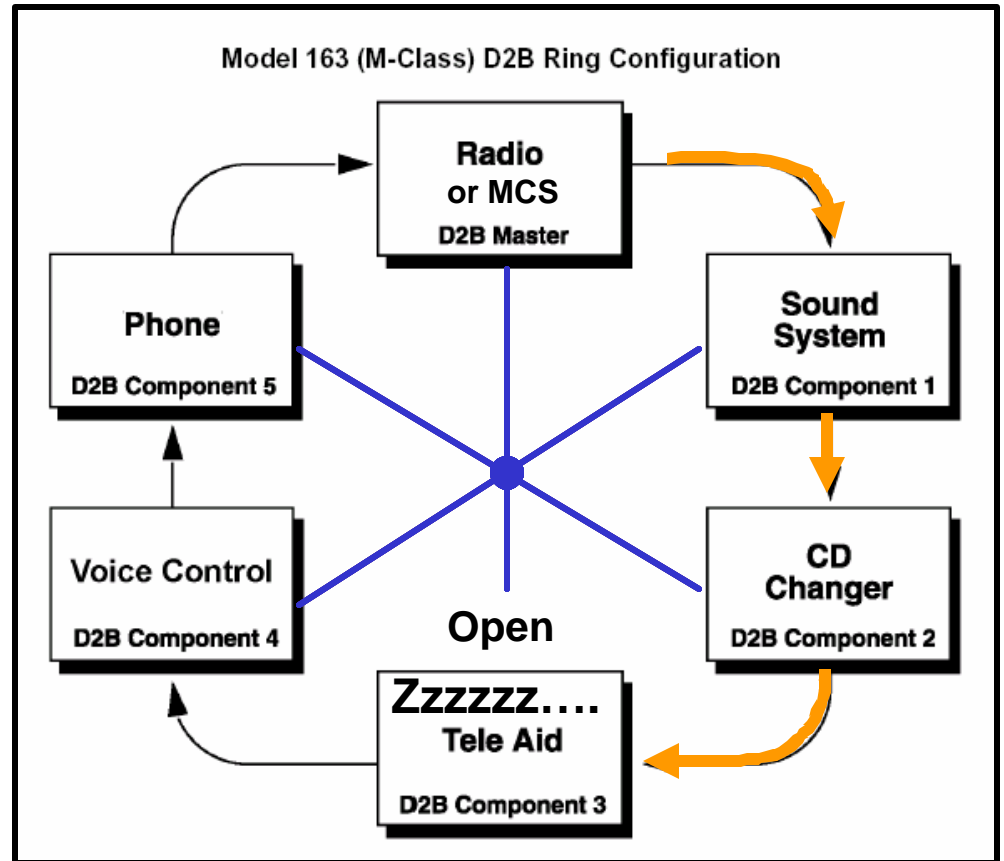
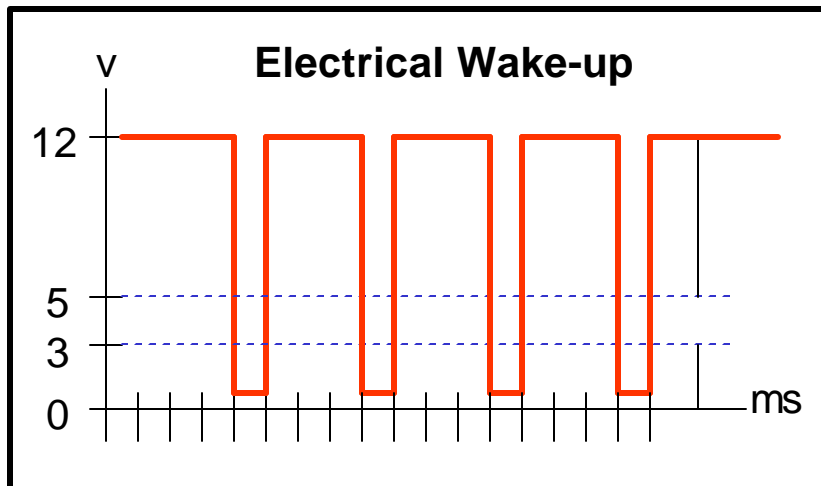

Tip: D2B components may be heard clicking during this process indicating that they are electrically awake.

# Ring Start (with open at TELE AID)

- After the 4th attempt with no ring lock established, all D2B components that are awake send a 'roll call' pulse back to the master
- In this case only 2 'roll call' pulses were received by the master
  - this information is used to determine fault location
- Ring lock cannot be established
- No further attempts are made to start ring (components go back to sleep), unless the system is switched on again

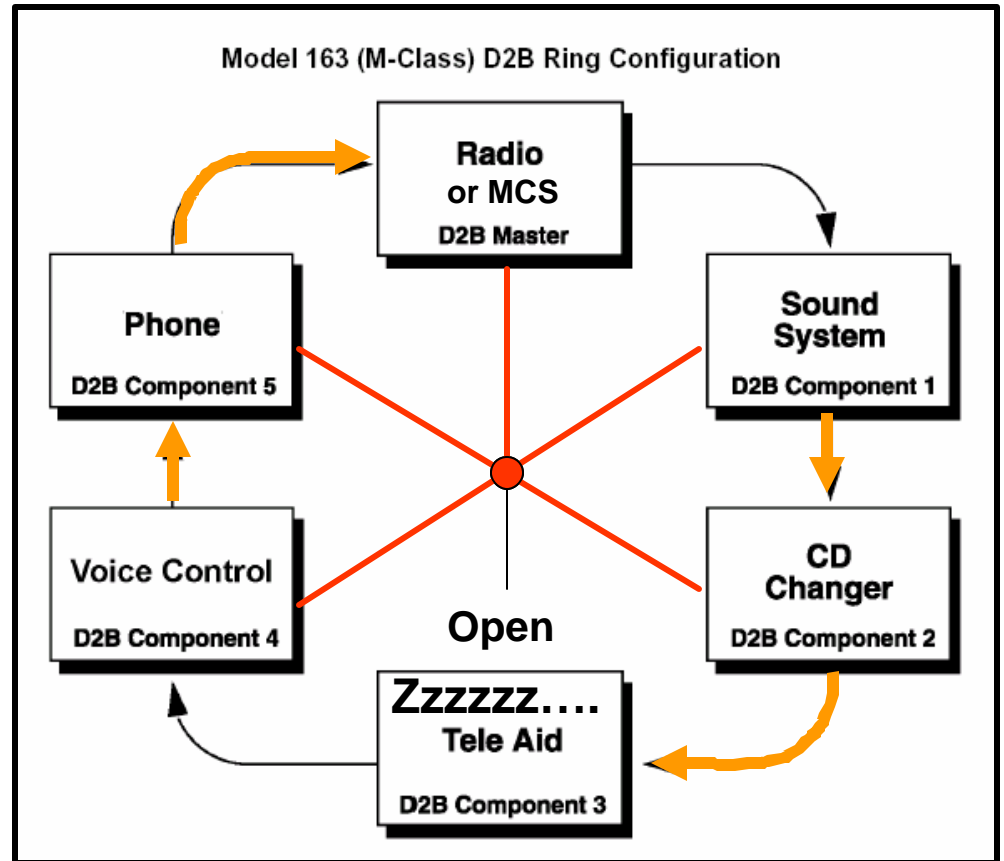

# Determining Fault Location

- ‘Roll call’ messages that returned to master, indicate number of components able to communicate with master on the optical ring
- Appropriate fault code stored *e.g. N1111 no data transferred between D2B master and a D2B component possible: The component at location \_ reports a fault in the ring.*
- Location (or position) number indicates number of components master heard back from, counting around the ring backwards

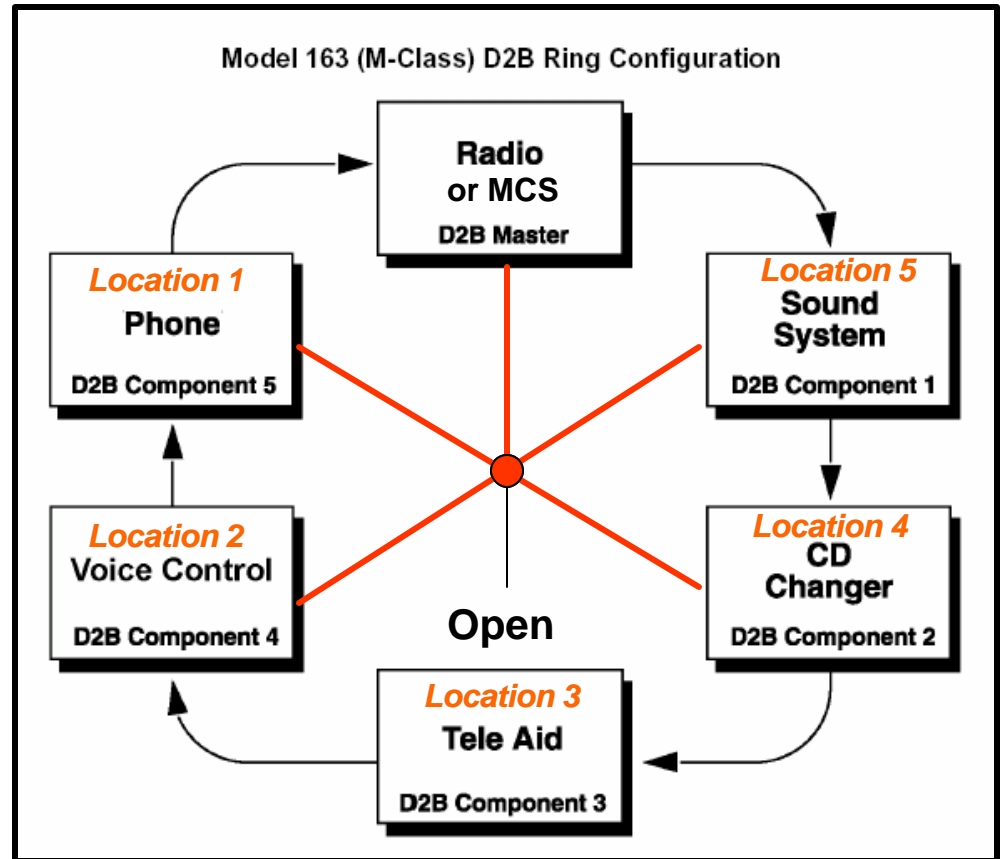

# Electrical or Optical Fault?

- Fault code does not indicate what the fault is, only the location that was last heard from.

*e.g. N1111 no data transferred between D2B master and a D2B component possible:  
The component at location \_ reports a fault in the ring.*

- To determine if the fault is electrical or optical we can perform a 'test of the wake-up line to all components' using the SDS / DAS. This is sometimes referred to as a diagnostic wake-up.
- When prompted, Master will issue an extended wake-up signal that the D2B components will respond to
- D2B components on the ring will each respond by pulling the wake-up line low at specific time intervals
- Master will monitor wake-up line and via SDS / DAS display results of the test

# Diagnostic Wake-up (Normal)

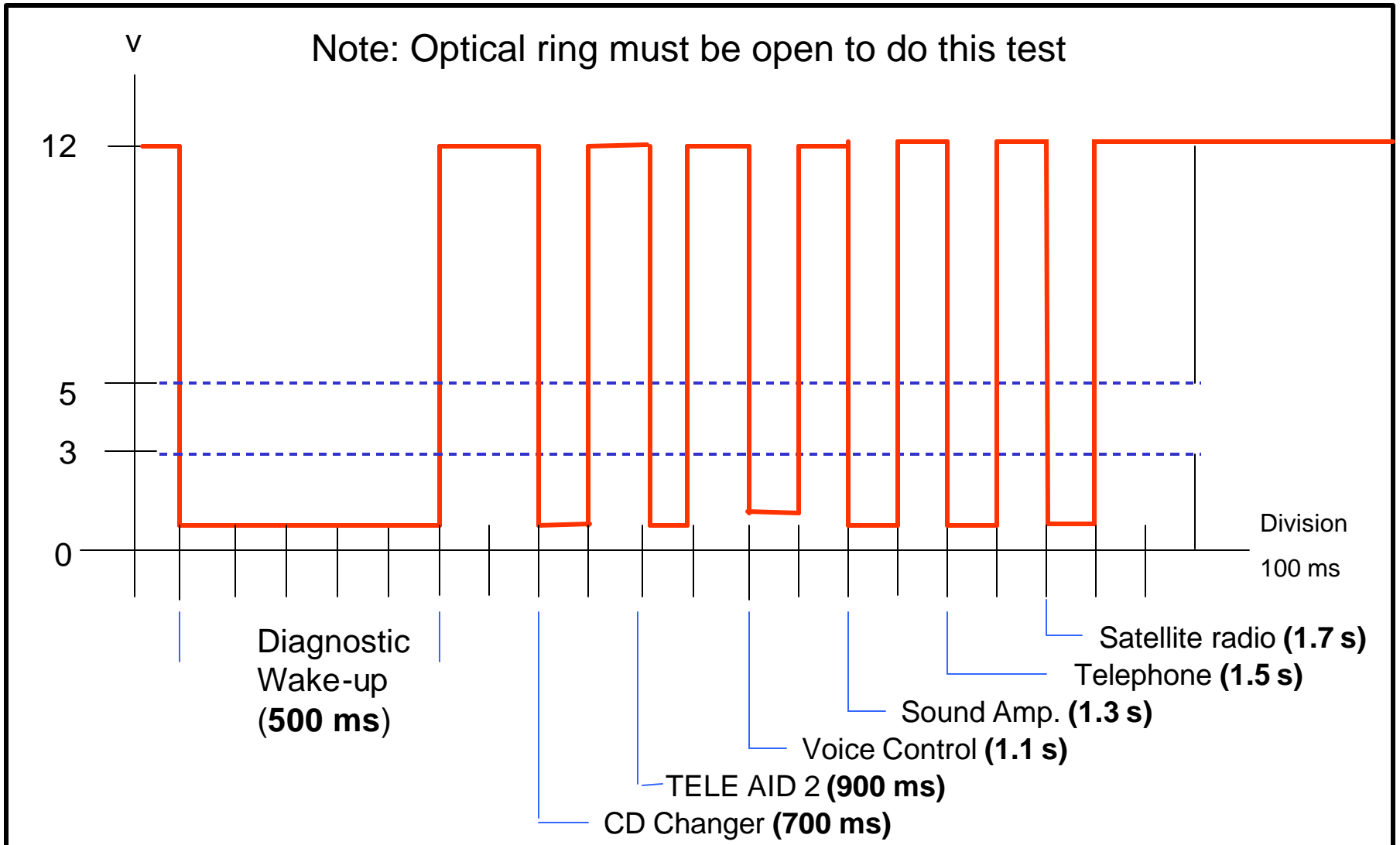

Indicates no electrical problem, if fault exists it may be optical.

# Diagnostic Wake-up (With Fault)

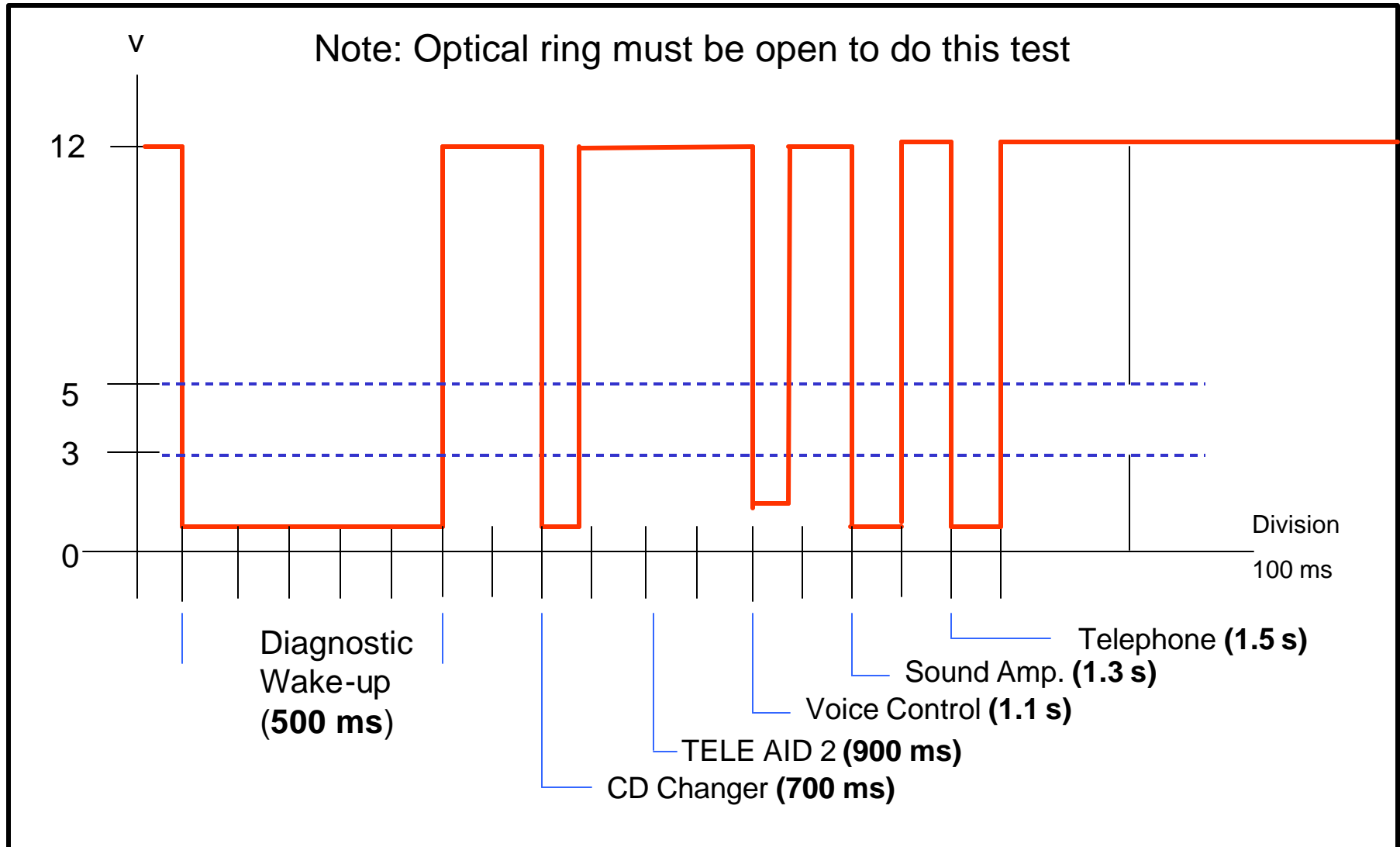

Indicates an electrical problem with TELE AID (if installed)

# Electrical or Optical Fault?

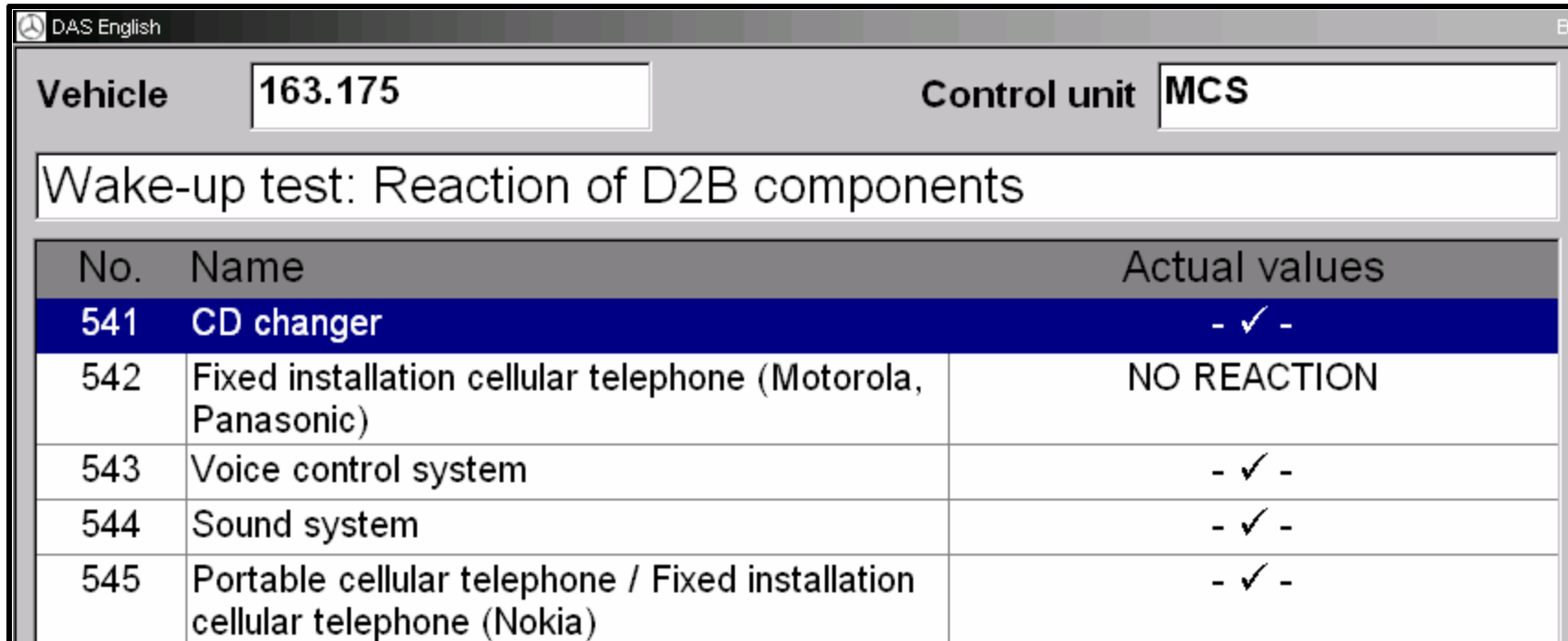

| No. | Name  | Actual values |
|-----|---|---------------|
| 541 | CD changer  | - ✓ -         |
| 542 | Fixed installation cellular telephone (Motorola, Panasonic)                 | NO REACTION   |
| 543 | Voice control system  | - ✓ -         |
| 544 | Sound system  | - ✓ -         |
| 545 | Portable cellular telephone / Fixed installation cellular telephone (Nokia) | - ✓ -         |

NO REACTION = Component not fitted or electrical problem at component  
- ✓ - = Component responded (electrically OK):

# Visual Check of D2B Ring

- Remove an optical plug connector from one of the D2B components
- Switch ON the head unit
- Observe the red fiber end of the removed connector (angled side), watching for optical flashes
- What you *should* see:
  - 4 to 5 flashes indicate that D2B circuit is *probably* OK up to that component (incoming optical cables and preceding components) \*
- Repeat while observing the component's cable connector socket
  - 1 flash from the component after the 4 flashes occur at the cable indicates:
    - Component power and ground connections are OK
    - Master has successfully awakened component electrically
    - Component FOT is attempting to inform Master that it is **OK** \*



\* *Note: Light intensity is critical.*

*This visual check simply verifies the presence of light signals.*



# Optical Signal Strength - Attenuation

- Weakening of the signal
- In D2B, attenuation would indicate a loss of light signal strength within the ring - attenuation is usually measured in decibels (db)

*Decibel: A unit of measurement indicating relative power expressed on a logarithmic scale. Often expressed in reference to a fixed value.  
(i.e. 0db is the reference value for optimal light strength)*

- Fiber optic cable routing conditions may cause pinching, smashing, scraping, fracturing or excessive kinking

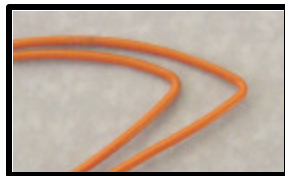

- Ageing of fiber optic cables may also be a further concern.
- These conditions may be the cause of error messages on the display or complete / intermittent loss of sound
- These conditions may cause signal attenuation to exceed allowable limits

Refer to T-B-82.60/194 of May 6, 2002 for ML solutions

# Signal Strength and Ring Lock

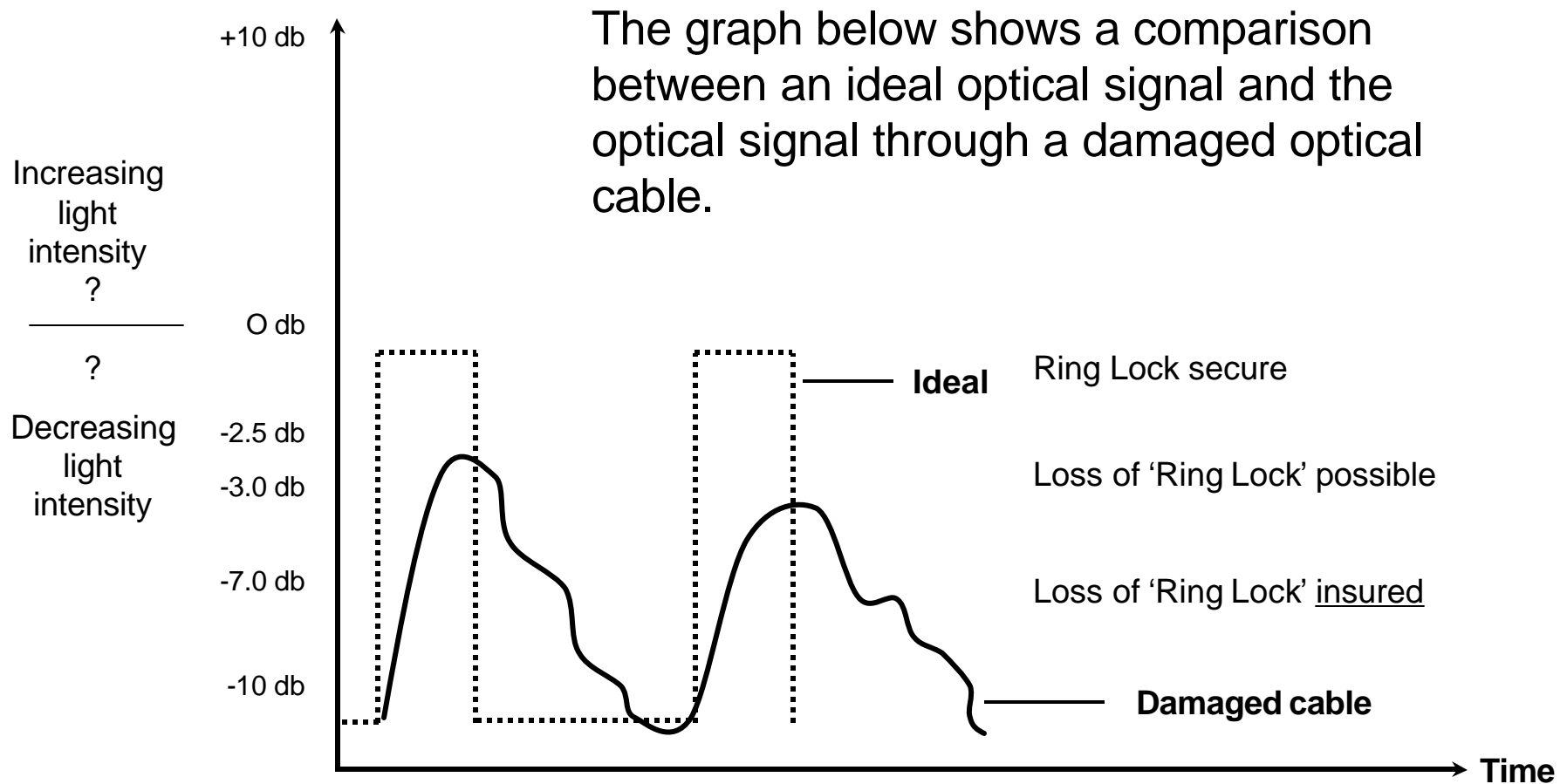

Note: Signal strength can also affect shift phasing.

# Fiber Optic Cable Damage

- A2 - Radio / MCS
- A2/6 - CD changer
- A2/13 - Sound amplifier
- A2/56 - MCS with NAV
- A35/8 - TELE AID

- 3 - optical cable from MCS to sound amplifier
- 4 - optical cable from sound amplifier to CDC
- 5 - optical cable from CDC to TELE AID
- 6 - optical cable from TELE AID to MCS

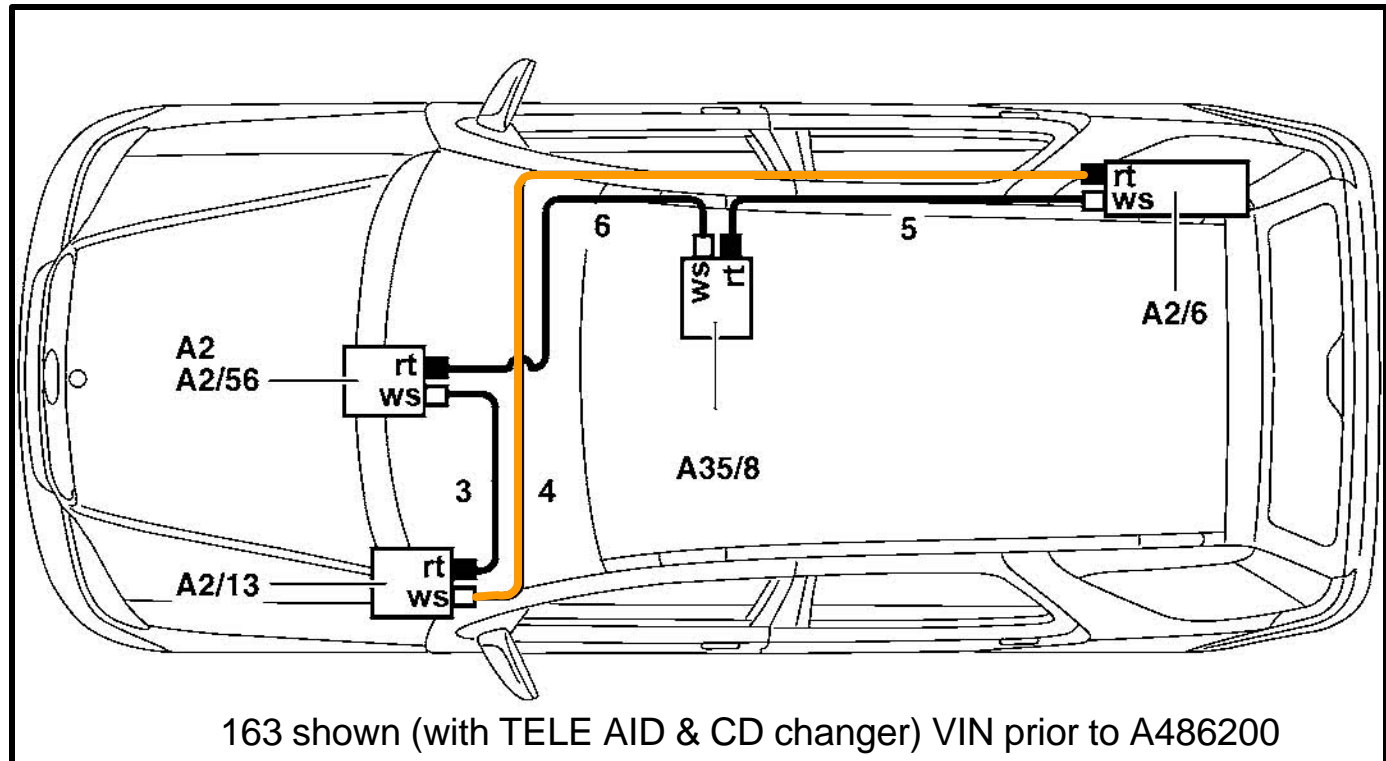

The complete length of a fiber optic cable is not visible and sometimes can run the length of the vehicle (see above). Before replacing an optical cable for a suspected loss of signal, check it first with a pair of D2B testers.

# D2B Network Tester

- Tester kit includes:
  - 2 units
  - a short circuit plug
  - instruction book
- Transmits light:
  - checking optical cable
- Measures the light received
  - checking optical cable
  - checking component output
- Can be used as a repeater  
(substituting a component)
- Powered by 2 AA batteries



# D2B Tester: Power ON check

1. Switch unit ON
2. All LED's should light once as a self-check:
  - High level - blue
  - Power - red
  - Power - green
  - Level - red
  - Level - green
3. "Power" LED should then keep flashing green if battery OK.

Note: Always check batteries before using.  
Check both units!

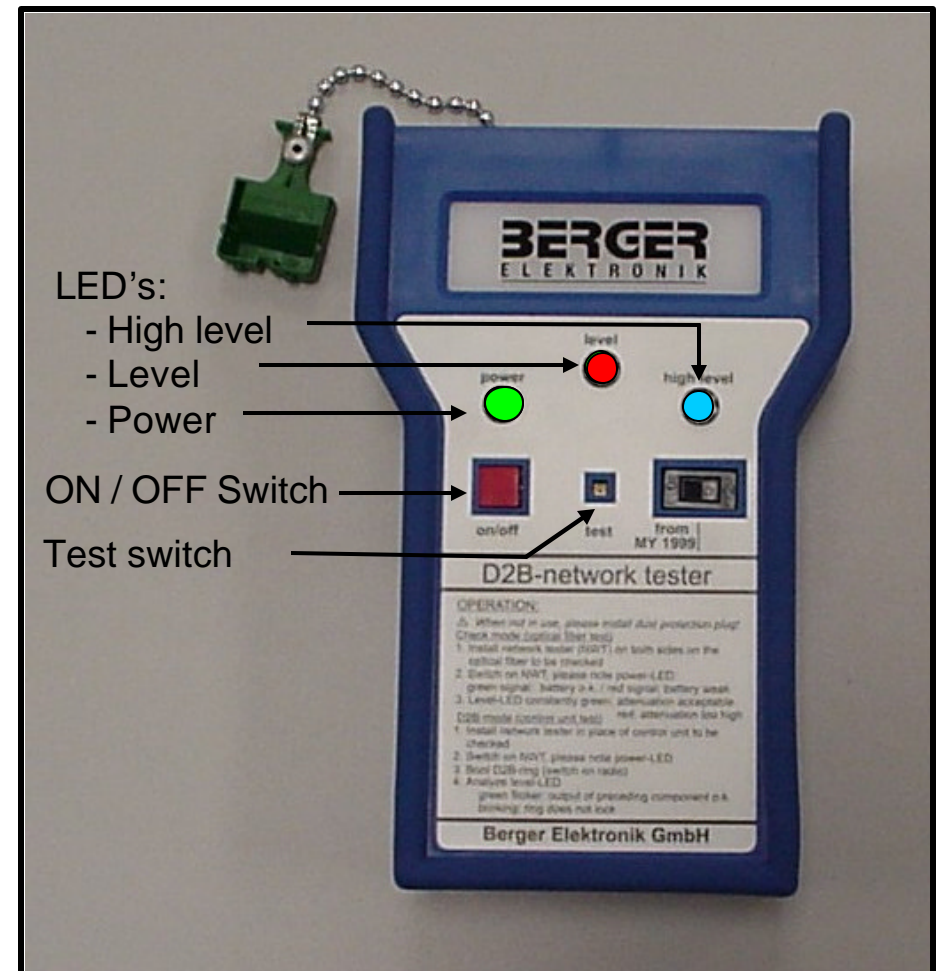

# D2B Tester: Calibration Check

After testing the batteries, calibrate each unit by:

1. Install short circuit plug in socket of network tester
2. Turn on network tester
3. Press “test” button on tester with a pointed object for ~1 second
4. “level” LED on tester should flash green 3 times (3<sup>rd</sup> time it stays on)
5. If LED flashes red and unit shuts off, attempt cleaning short circuit plug or network tester FOT's

Note: Use dry eyeglass cloth or cotton swab, spray compressed air from aerosol can

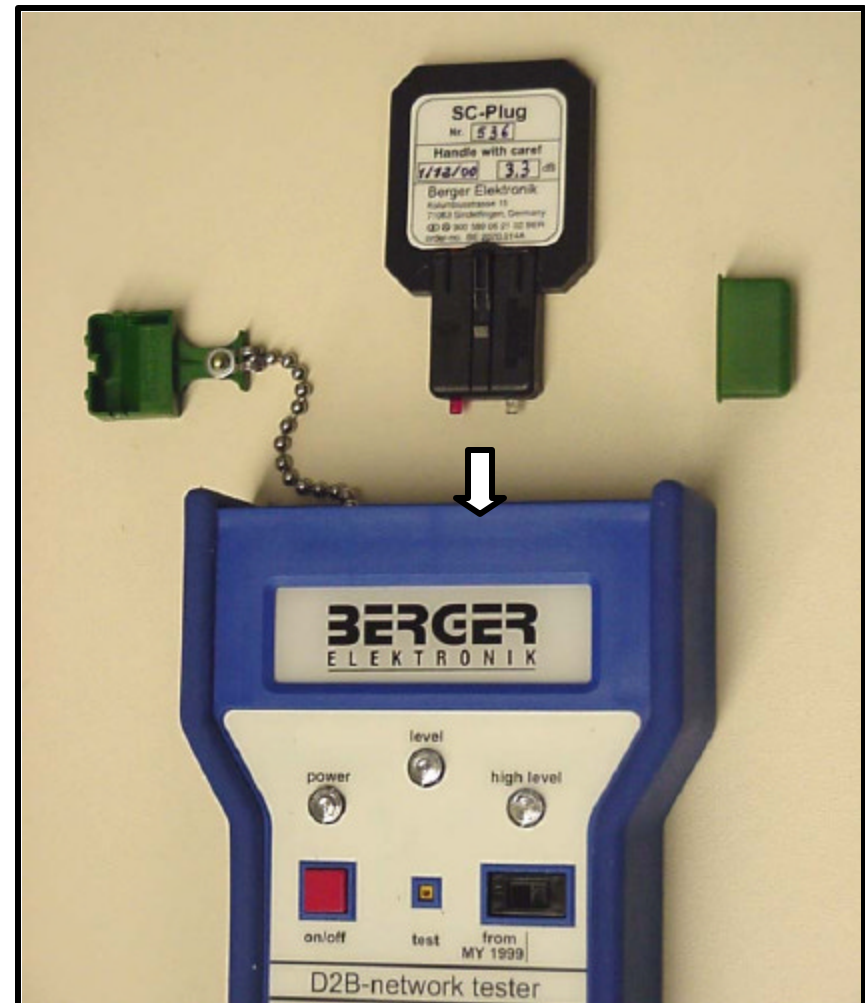

# Using D2B Tester

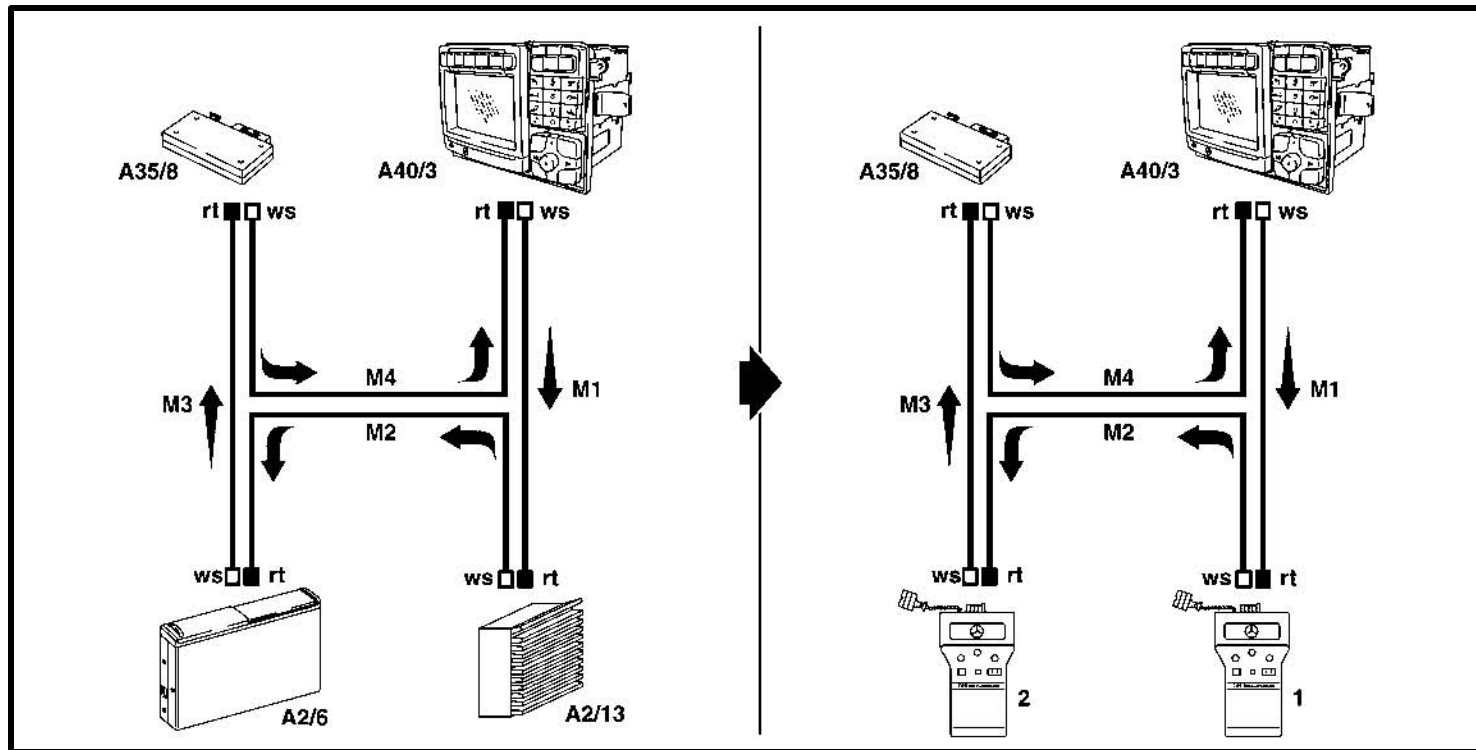

To test optical cable M2:

- Insert fiber optic connector from A2/13 into tester 1
- Insert fiber optic connector from A2/6 into tester 2
- Tester 1 will transmit light, which will be received and evaluated by tester 2
- Observe level reading on receiving D2B tester (2)

- steady green = OK    - red / green = marginal    - steady red = fiber bad

# Using D2B Tester

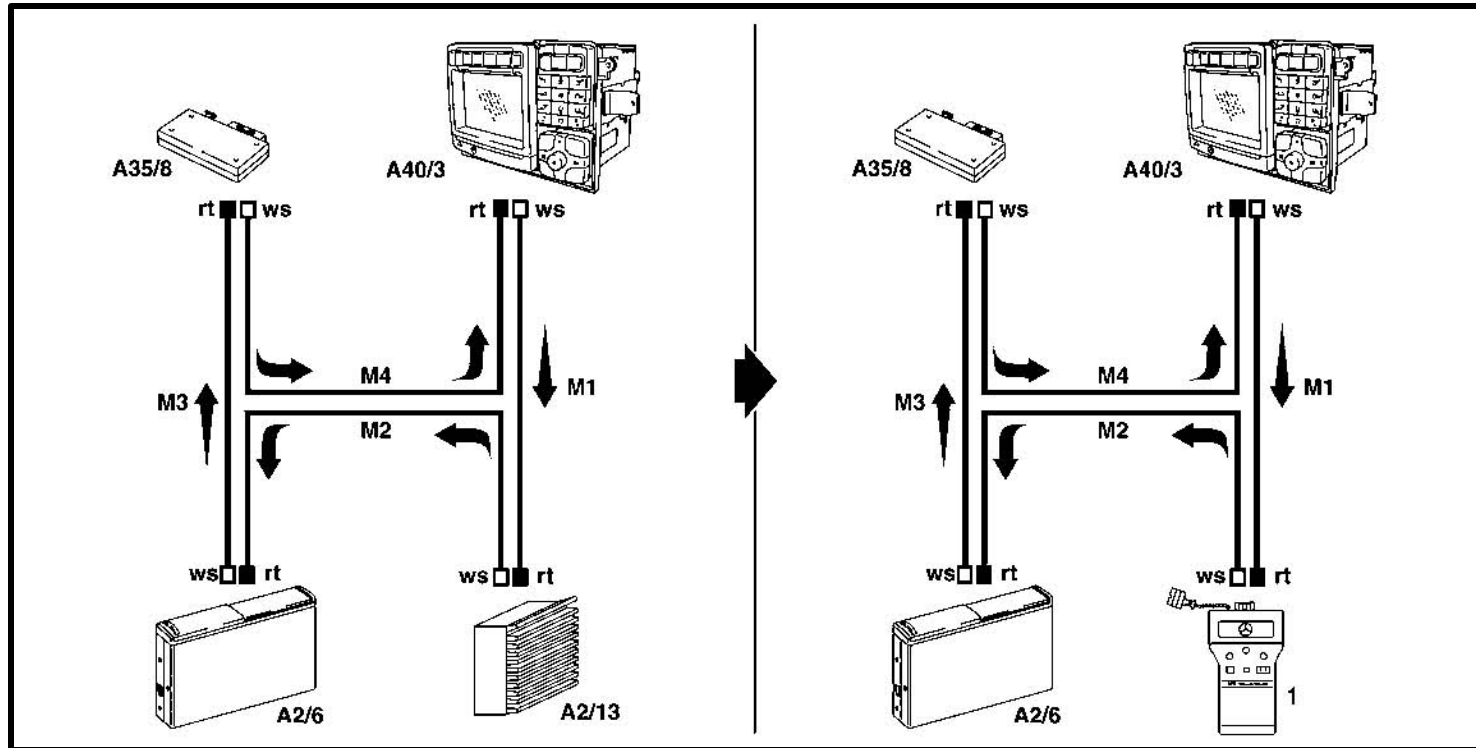

To substitute a component (e.g. A2/13):

- Insert fiber optic connector from A2/13 into tester 1
  - Recommend disconnecting electrical connector on substituted component
  - With tester switched on, operate audio system to try and get 'ring lock'
  - Tester 1 will repeat what ever it is sent from predecessor component
- green flicker = OK - red flicker = weak signal - blue 'high level' = optical output too high



# **Additional Diagnosis Resources**

EDAC Diagnosis Resources

COMAND On-Board Diagnosis

AUDIO 30 On-Board Diagnosis

DTB's

# EDAC

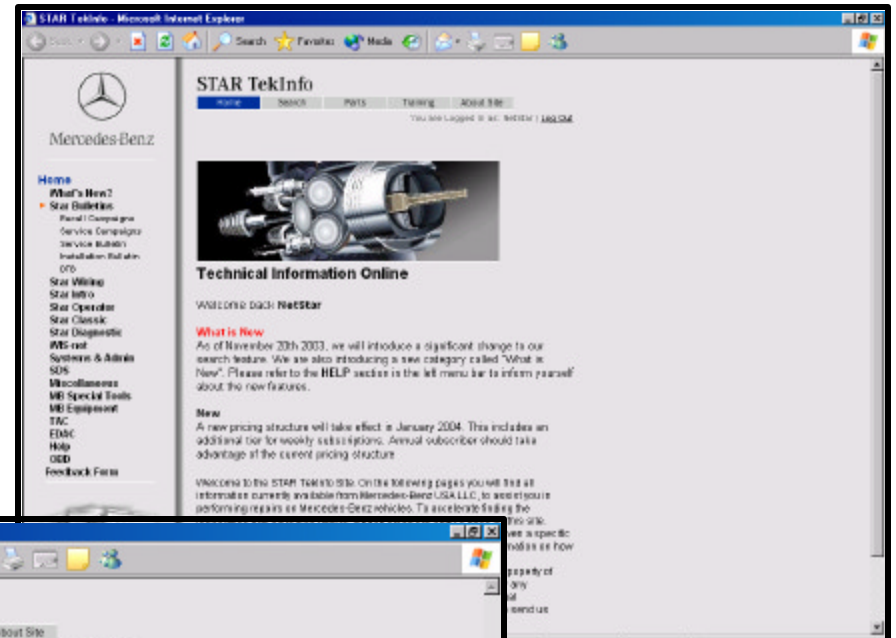
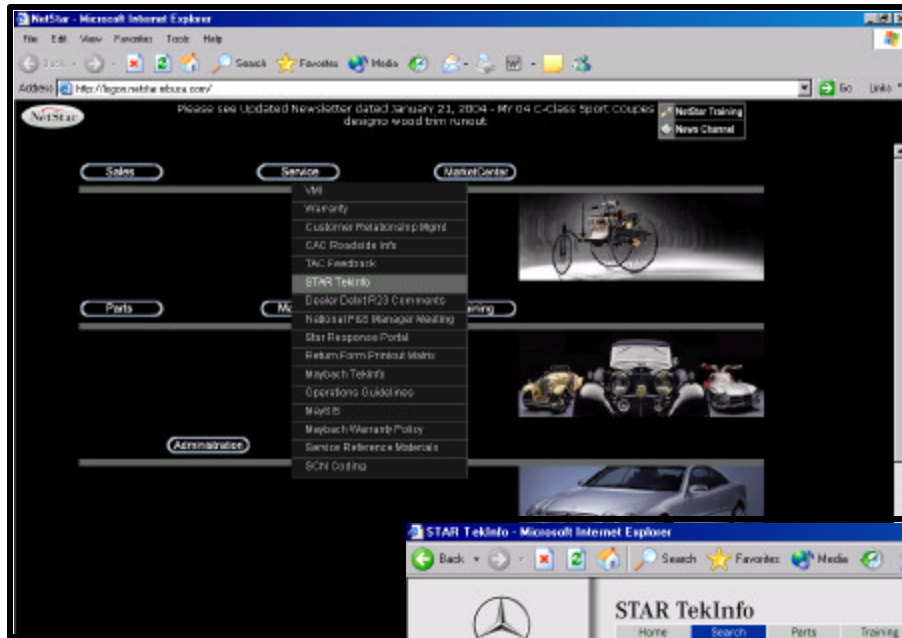

# COMAND On-Board Diagnosis



# TELE AID Removed from D2B (163)

As of VIN #A486200

TELE AID was on the optical ring to enable information for 'Info Services' to be displayed on the HU. With this feature now being discontinued there is no need for TELE AID to be on the optical ring.

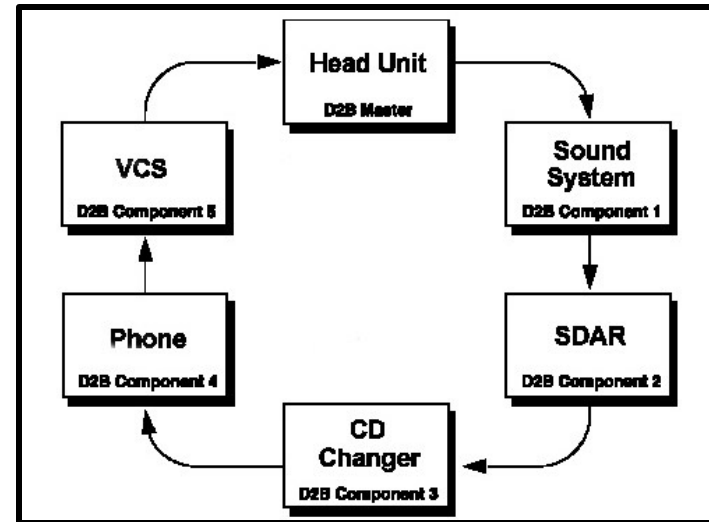

System configuration showing optional equipment  
Satellite radio receiver (SDAR) available on 2004

Note: Earlier ML's may have had TELE AID  
control module removed from the optical ring.

If TELE AID is removed from the optical ring on 163  
or R170:

- sound will not mute, when a TELE AID call is made
- TELE AID system uses back-up speaker

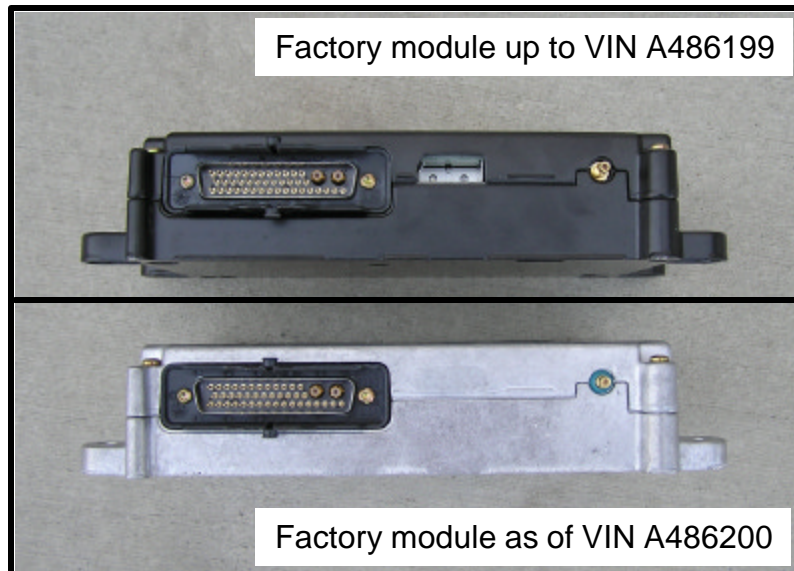

# MCS Volume Control Notes

- MCS units will not start at high volume levels regardless of the volume that was set when the vehicle was turned off.
  - This is a normal operational characteristic to protect the speakers
- Navigation voice volume can only be adjusted while in use
- Sound system volume surges or increases to maximum volume unexpectedly in CD, AM or FM modes
  - Change version coding. See DTB: T-B-82.60/192 of 4/16/02
  - Check Audio Pilot microphone function
    - substitute a resistance for microphone to verify cause is microphone