

MODEL 231

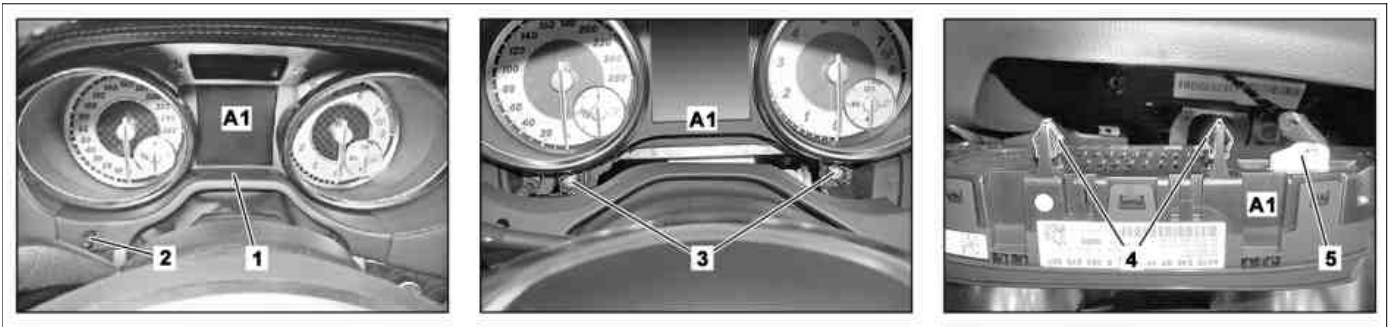

P54.33-2683-07

1 Lower paneling
2 Adjuster

3 Screw
4 Clip

5 Electrical connector
A1 Instrument cluster

6 Extraction hook
A1 Instrument cluster

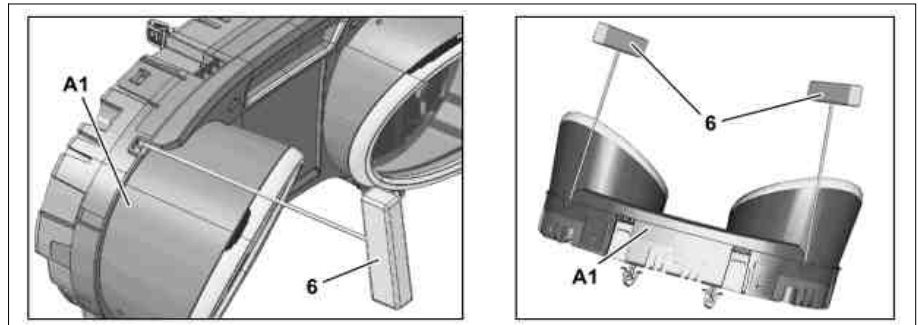

P54.32-9308-04

	Information on preventing damage to electronic components due to electrostatic discharge		AH54.00-P-0001-01A
	Remove/install		
1 	Connect STAR DIAGNOSIS and perform initial startup on instrument cluster (A1) Connect STAR DIAGNOSIS and read out fault memory	When replacing the instrument cluster (A1).	AD00.00-P-2000-04A
2	Move steering wheel all the way to the rear and down		
3	Switch off ignition and remove transmitter key (A8/1) or KEYLESS-GO start/stop button (S2/3) from electronic ignition lock control unit (N73)	KEYLESS-GO start/stop button (S2/3) only with CODE (889) KEYLESS-GO.	
4	Unclip lower cover (1) from instrument panel and slide to rear	Installation: Insert adjuster (2) into lower cover (1). Long wedge	*115589035900
5	Remove screws/bolts (3)	The bolts (3) remain on the instrument cluster (A1).	
6	Release instrument cluster (A1) with two extraction hooks (6) and remove to the rear from the instrument panel	The instrument cluster (A1) is clipped in with clamps (4) to the instrument panel. Extraction hook	*140589023300
7	Remove instrument cluster (A1)	To do so, swivel instrument cluster (A1) at top out of instrument panel and detach electrical connection (5).	
8	Install in the reverse order		

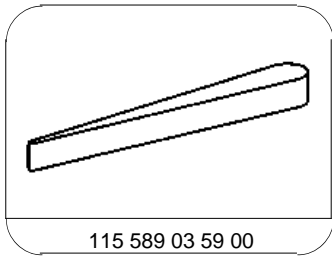

115 589 03 59 00

Long wedge

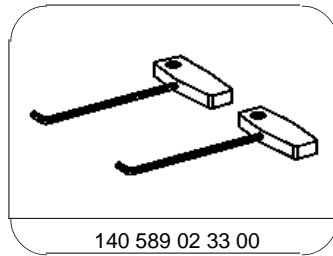

140 589 02 33 00

Extraction hook