

GF15.15-P-3000M	ECI ignition system, function	1.7.03
-----------------	-------------------------------	--------

ENGINE 275.951 /981 in MODEL 230

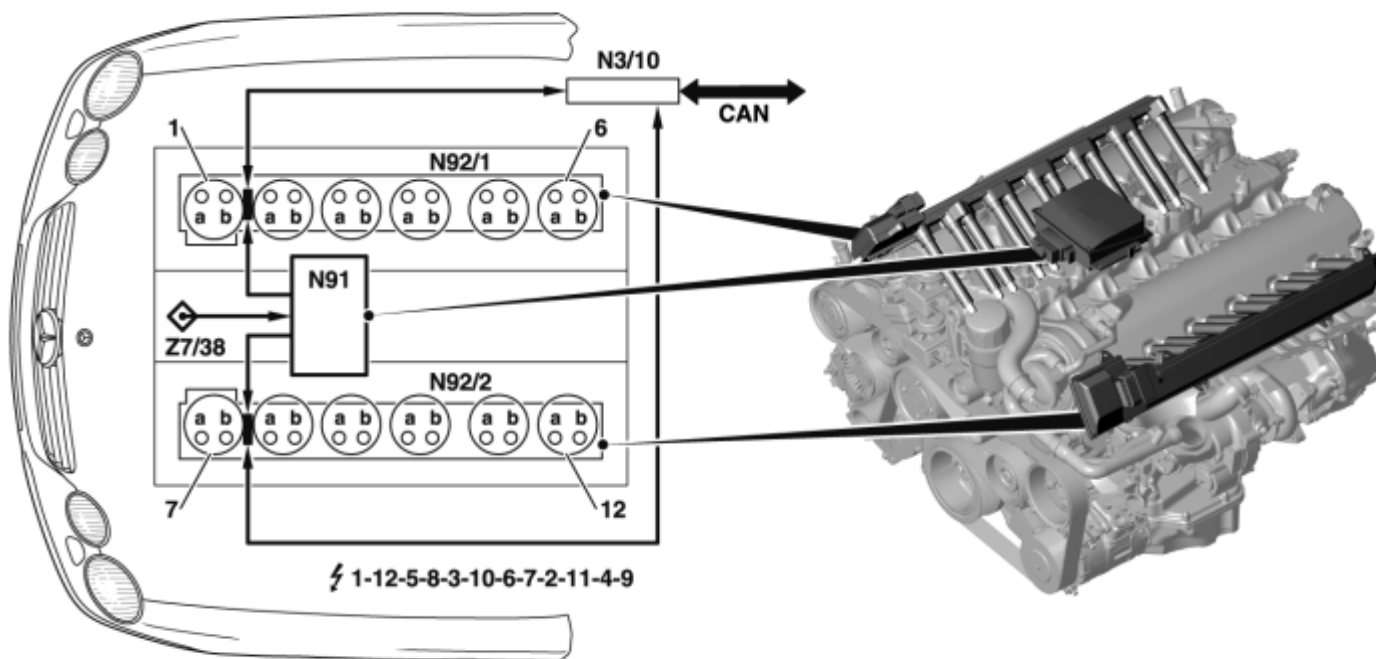

P07.61-2915-09

1...12 Cylinders 1 to 12  
 a Spark plug, ignition circuit a  
 b Spark plug, ignition circuit b  
 N3/10 ME-SFI [ME] control unit

N91 ECI ignition system mains unit  
 N92/1 ECI ignition module, right cylinder bank  
 N92/2 ECI ignition module, left bank of cylinders

Z7/38 Circuit 87 M1i connector sleeve (voltage supply)  
 CAN Data bus

	ME-SFI control unit	ECI ignition module, right cylinder bank
--	---------------------	--

<b>ECl ignition module, left cylinder bank (N92/2)</b>		<b>(N3/10), coupling 3</b>		<b>(N92/1)</b>
ion current signal cylinders 7 to 9 Pin 6	→	Pin 32 Pin 33	←	Pin 6 ion current signal cylinders 1 to 3
ion current signal cylinders 10 to 12 Pin 7	→	Pin 45 Pin 46	←	Pin 7 ion current signal cylinders 4 to 6
Ground, ion current signals Pin 5	-----	Pin 44 Pin 47	-----	Pin 5 Ground, ion current signals
Ignition trigger signal, cylinder 7 Pin 1	←	Pin 37 Pin 49	→	Pin 1 Ignition trigger signal, cylinder 1
Ignition trigger signal, cylinder 8 Pin 2	←	Pin 2 Pin 1	→	Pin 2 Ignition trigger signal, cylinder 2
Ignition trigger signal, cylinder 9 Pin 3	←	Pin 35 Pin 24	→	Pin 3 Ignition trigger signal, cylinder 3
Ignition trigger signal, cylinder 10 Pin 4	←	Pin 14 Pin 28	→	Pin 4 Ignition trigger signal, cylinder 4
Ignition trigger signal, cylinder 11 Pin 13	←	Pin 38 Pin 50	→	Pin 13 Ignition trigger signal, cylinder 5
Ignition trigger signal, cylinder 12 Pin 12	←	Pin 36 Pin 51	→	Pin 12 Ignition trigger signal, cylinder 6
Ignition offset cylinders 7 to 12 Pin 10	←	Pin 29 Pin 15	→	Pin 10 Ignition offset cylinders 1 to 6
Ignition change (ignition circuit a/b) Pin 11	←	Pin 30 Pin 43	→	Pin 11 Ignition change (ignition circuit a/b)
		<b>ECl ignition system power pack (N91)</b>		
Battery voltage, terminal 87 Pin 15	←	Pin 13 Pin 12	→	Pin 15 Battery voltage, terminal 87
Ground Pin 8	-----	Pin 14 Pin 11	-----	Pin 8 Ground
Auxiliary voltage approx. 23 Pin 14	←	Pin 8 Pin 7	→	Pin 14 Auxiliary voltage approx. 23 V
Voltage approx. 180 V Pin 16	←	Pin 16 Pin 9	→	Pin 16 Voltage approx. 180 V
<b>Voltage supply</b>				
Voltage supply	→	Pin 4	⊥	
Circuit 87	→	Pin 5		

The short name for the AC ignition system ECl means:

The ignition system ECl consists of:

**E** = Energy (energy)

**C** = Controlled (controlled)

**I** = Ignition (ignition system)

The ignition system ECI must initiate combustion by creating a spark at the spark plugs. This requires an adequately high voltage for generating a spark at the end of the spark plug and the sparks must also have sufficient energy to ensure guaranteed combustion of the fuel / air mixture.

The ignition system must be insensitive to carbon fouled spark plugs and guarantee a high spark plug working life.

The ignition system ECI has the following sub-functions:

1. Generation of the ignition voltage (ac voltage).

There is an output stage for each spark plug in the ignition modules. The ignition coils are arranged in the spark plug connectors. The output stages with oscillating circuit generate the ignition voltage from an input of about 180 V.

The ME control unit produces the following actuation impulses:

- Triggering of the ignition spark according to the ignition angle
- Permanent control of the ignition process
- Change of ignition
- Ignition offset

- The ignition module ECI for the right cylinder bank
- The ignition module ECI for the left cylinder bank
- ECI ignition system mains unit
- Evaluation circuit for the ion current in the ME control unit
- Actuation of the ignition system ECI by the ME control unit
- Ignition map in the ME control unit.



No spark tests can be undertaken with the ignition system ECI.

2. Measurement of the ion current.

There is a switchover to ion current measurement at the end of the ignition spark phase and the ion current on the spark plug is measured with the help of an auxiliary voltage of about 23 V. Evaluation of the ion current signals takes place in the ME control unit. The signals are used for detection of combustion misfires at high rpms.

3. The power pack generates the required voltages of two times about 180 volts and two times about 23 volts.

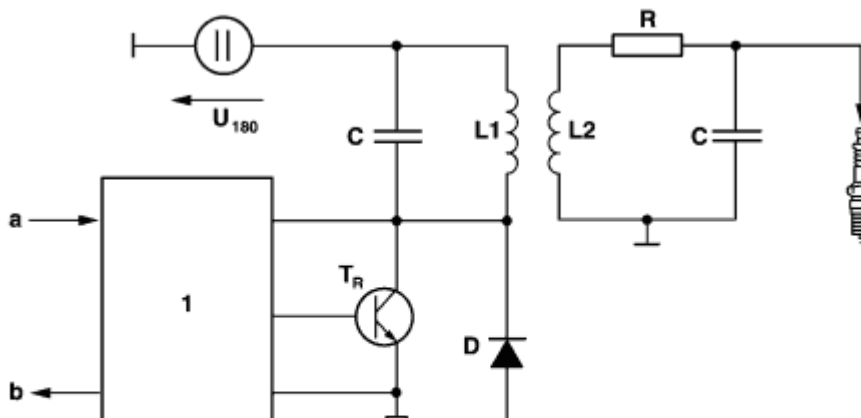

P15.10-2048-05

**Generation of the ignition voltage (ac voltage)**

1 Actuation of ignition and ion current uncoupling in the ignition module

L1 Primary winding

L2 Secondary winding

a Actuation of the ME control unit

b Ion current signal at ME control unit

The ignition voltage is generated in two steps:

1. Transistor (TR) closed - the voltage U180 is transferred to the secondary side.
2. Transistor (TR) opened - the negative half wave of the AC voltage develops and is also transferred to the secondary side.

Control of the transistor can theoretically allow generation of an AC voltage of any desired duration and energy level.

**Permanent control of the ignition process**

Adjustment of the spark energy over the spark duration to the actually required ignition energy of the fuel / air mixture occurs controlled by the ME control unit according to the performance map.

The spark plugs enjoy 4 times their usual working life due to spark duration control. Combining this at the same time with the use of spark plugs with platinum electrodes allows the working life to be extended even further.

**Ignition offset and ignition change**

In the lower part load range up to approx. 2000 rpm both ignition sparks of a cylinder are triggered simultaneously. At moderate and high engine loads, the ignition sparks are triggered offset by as much as 10° crank angle. Here the order of actuation is changed each 720° crank angle in order to achieve even wear of both spark plugs in a cylinder and to prevent one-sided accumulation of deposits in the combustion chamber.

The chemical formula for the creation of ions in the flame is:

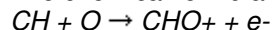

C Capacitor

D Diode

R Resistor

TR Transistor

U 180 DC voltage approx. 180 V

The maximum spark burning period is, however, limited by the rated output of the power pack ECI of two times 55 watts depending on the engine speed to about 0.15 to 1.5 msec. A spark burning period of about 0.1 msec is usually quite adequate for guaranteed combustion of the fuel / air mixture. The rapid increase in ignition voltage makes the ignition system ECI insensible to carbon fouled spark plugs e.g. due to frequent cold starts.

**Ion current measurement**

Ions are created in the flame front during combustion (particles which have various different electrical charges) which balance each other out again in the burnt mixture. The application of a relatively small measuring voltage to the end of the spark plug allows one to measure this ion current through the flame. The measuring voltage is applied to the primary side of the ignition coils (auxiliary voltage of about 23 volts). This gives an AC voltage on the secondary side of about 1 kV with about 65 kHz on the spark plug electrodes. The ion current modulates this voltage. Decoupling and filtering allows one to obtain an ion current signal. The ion current signal gives information about the rate of cylinder pressure with a degree of accuracy, which allows the detection of combustion misfirings.

The ion current signal is transferred to the control unit ME for every 3 cylinders. The cylinder concerned in each case is allocated in the control unit ME with the help of measuring windows.

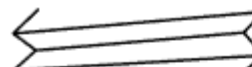

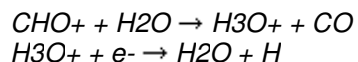

P15.10-2049-01

Ion current measurement at the spark plug delivers a signal directly from the combustion chamber without the use of any additional components such as combustion chamber pressure sensors. The measurement is taken after ignition has been initiated by both spark plugs and

a short waiting time. The measurement is only taken on the spark plug which first sparked. The distance between the electrodes does not have any effect on the ion current signal.

- A Behaviour pattern of the ion current signal*
- B Behaviour pattern of the cylinder pressure*
- C Knock vibrations*
- d Measuring window position for ion current measurement*

The profiles of the ion current signal and cylinder pressure are the same during combustion.

Through this behaviour, the evaluated ion current signal is used to detect combustion misfires reliably in all operating conditions and at all engine speeds. This is used for actuating the spark duration, for spark plugs diagnosis, for diagnosis according to OBD or EURO4 and for cylinder specific fuel cut-off.

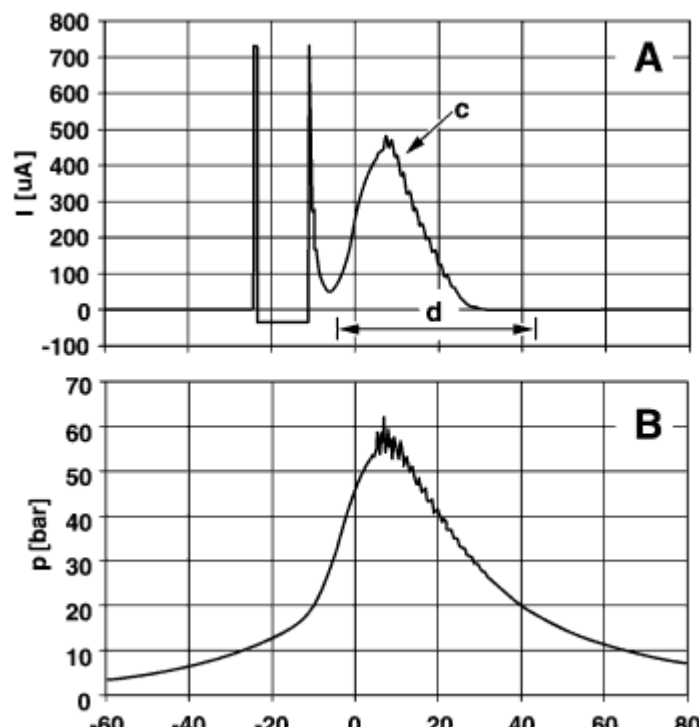

P15.10-2050-12

ECI ignition system power pack location/task/design/function	<a href="#">GF15.15-P-3100M</a>
Ignition module, location/task/design/function	<a href="#">GF15.15-P-3101M</a>
ME-SFI control unit, location/task/design/function	<a href="#">GF07.61-P-5000M</a>